



Metso
Screening
media

Handbook

Version 1.3





Table of contents

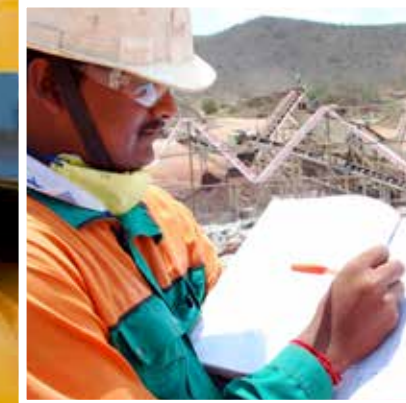

Introduction	
Working together for you.....	2
Screening media and lining solutions you can count on	4
Production and material technology.....	6

Applications	
Mining applications	
Pre-grinding ore.....	10
Pre-heap leach	12
High grade ferrous ore.....	14
Mill discharge screens	16
Dense media circuits	18
Control screening – fines removal	20
Construction applications	
Soft rock.....	22
Hard rock.....	24
Sand and gravel	26

Modular system		30
Trellex LS Standard range	31	
Trellex LS HiPer range.....	56	
Trellex LS HiPer Flow.....	58	
Trellex LS HiPer Life.....	60	
Trellex LS HiPer Clean.....	62	
Trellex LS HiPer Drain	66	
Trellex LS-S side modules.....	67	
Trellex LS accessories	104	
Trellex LS installation	135	
Trellex 305PS	162	

Tension system		169
Trellex TFX.....	170	
Trellex TCO RU.....	172	
Trellex TCO PU.....	176	
Trellex PCL.....	184	
Trellex CLS.....	186	

Panel system		193
Trellex MP	194	
Trellex PCO	205	

General Screening media accessories		212
Trellex CMP.....	212	
Screen feedbox and discharge spout lining.....	221	
Trellex Dust control.....	227	
Trellex Spray nozzles.....	230	

Supporting material		232
Selection guide.....	232	
Screening process theory.....	240	

Working together for you



Metso is a global supplier of sustainable technology and services for mining, construction and oil & gas industries. As a **full-service partner** to these industries, Metso relies on a global pool of more than 15,000 dedicated employees to help our customers achieve successful results in every part of their operation.

Metso screening media solutions reflect that commitment in every product and service we offer. Working closely with our customers, **we go beyond simply being a supplier** to consulting on and recommending genuinely customized solutions that help maximize productivity and profit for them.

That's how we live up to the Metso promise: **Expect results.** By investing in understanding the customer's business at every level, we become a true partner in helping them achieve all that is possible from every production site, wherever it is and whatever the challenges.

Your partner in maximum productivity

Metso screening media solutions have always been known for the quality of their construction, their dependability in the field and their ongoing innovation to find more productive screening options. That is why Metso screening media solutions have become the mining and construction **industry standard**. Customers and non-customers alike often turn to us for information and recommendations on all aspects of screening media.

Today, Metso screening media represent a flexible and reliable partnership in maximizing mining and construction site productivity. It goes beyond production, supply delivery and stockage of screening panel media. We advise on configuration. We proactively analyse all components of the crushing and screening operation to ensure that the solution maximizes production and minimizes downtime.

At the same time, we continue developing screening media materials and construction in our ongoing quest to always offer our customers more productive options matched to their exact needs. Partnering with Metso means having more options from the widest range of dependable screening media from a single source. Real-time access to production-enhancing developments as they become available. And the peace of mind of continuous support from a partner whose definition of success is **how well we contribute to yours.**



Screening media solutions you can count on

Whatever the application, there is a Metso screening media solution to match. Metso screening media are **adaptable to all environments and tasks**. The range is designed to offer maximum productivity without compromising quality.

Options are available from fine to coarse in **both wet and dry applications**. Media equipment is made of the wear-resistant material best suited to the screening process and budget, and is easily adaptable for stationary and mobile crushing plants.



Trellex LS This modern range of modular screening media helps customers achieve higher volume processing with minimal interruptions. Developed for maximum flexibility in configuration, Trellex LS screening media are tailored to the exact operating requirement.

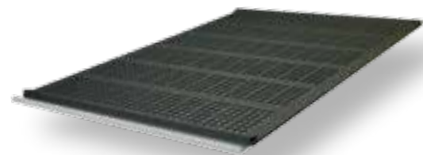

Trellex TFX A complete system based on a thin flexible soft rubber screen cloth to prevent material blinding makes Trellex TFX particularly well-suited to fine screening. Trellex TFX allows more open area and makes your operation more cost effective by reducing blinding.

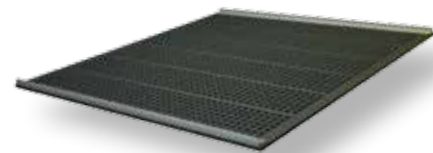

Trellex TCO Trellex TCO is well-known for its long service life. That means a lower wear cost per tonne of screened material – and higher profits for your operation. Trellex TCO is probably the most widely used rubber screen cloth in the world. An all-round cloth designed primarily for final products of 4 – 250 mm.

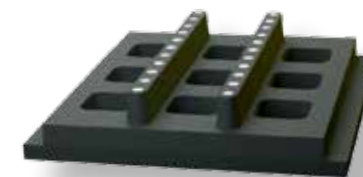

Trellex 610MP A proven favourite in mining and construction applications. This range is particularly well-suited to round-the-clock operations with screens in the same aperture size running all the time and where minimum downtime and low cost per tonne is crucial.

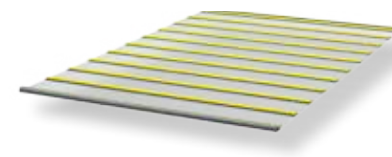

Trellex PCL (Poly-Clean) Trellex PCL is the latest innovation in screening media designed to improve your aggregate production. Increased wear life and capacity compared to classic wire.



Trellex CLS (Classic wire) A complete range of classic steel wire openings and diameters to enable us to provide you with the correct product for your application.

Production and material technology

As developments in materials technology continues to grow, so does Metso innovation in applying them to screening media. Steel is still the most widely used screening media material used today. But we believe that the best results for today's mining and construction operations are achieved by combining materials such as steel, rubber/ polyurethane – and taking full advantage of the best features of each. Compared to steel screening media, for instance synthetic screening media offers outstanding wear life, resulting in maximum productivity.

Lower costs

It's no secret that an easy way to increase profits is to lower unnecessary costs; starting with wear on equipment and the downtime it leads to.

For more than 40 years, Metso wear-resistant rubber and polyurethane products have demonstrated cost reductions in almost every tried application. Due to their high elasticity and impact absorption, rubber and polyurethane can withstand high crushing stresses without damage. Metso products also come in wear-resistant designs and are backed by our application know-how. Which lets you minimize the effects of general wear, lowering replacement expenses and minimizing costly downtime.



State of the art manufacturing

Maintaining the highest possible profit per tonne is important to our customers. And our customers are important to us.

That is why we invest heavily in the most advanced manufacturing techniques available. Polyurethane castings are made with a computerized and fully automatic carousel technique and an advanced injection-pressing method is used for TPU materials. Computerized injection presses are used in rubber manufacturing. On conventional presses, rubber and steel support plates are bonded together with a special adhesive at high pressure, ensuring proper adhesion. The result is product quality you can count on – and profit from.

Lean manufacturing – The Metso Way

Lean manufacturing makes good business sense for everyone.

The Metso Way is a collection of management systems implemented throughout the company. It is based on a number of key principles: do things right the first time, have operational stability, standardize work, be committed, deliver just in time and work continuous towards improvement. Third party assessed systems as SS-EN ISO 9001:2000 Quality Management, SS-EN ISO 14001 Environment and OHSAS 18001 Working Environment are the foundations on which we are building the Metso way.



Mining applications

Pre-grinding ore 12



Pre-heap leach 14



High grade ferrous ore 16



Mill discharge screens 18



Dense media circuits 20



Control screening - fines removal 22



Construction applications

Soft rock 24



Hard rock 26

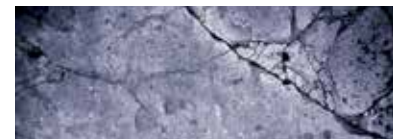

Sand and gravel 28



MINING: Crushing & screening

Pre-grinding ore



Pre-grinding is the process of crushing and screening ore to prepare it for grinding. The final screened product has a certain top size and size distribution optimized for feeding to the grinding mill with high throughput and a minimum of downtime. The screening process is typically dry with separations ranging from 5-150 mm. Using multi-slope screens in a “banana”-type formation is common as it’s a proven way to handle high tonnages of fines throughput.

Challenges

The main challenge from a screening perspective is to generate maximum possible throughput of grinding feed. Getting the accuracy of size right at this stage is important because there is a domino effect – inaccurate sizing will cause slowdowns during grinding. Flakiness of material won’t be a problem as long as the maximum feed size is not exceeded. But the material can be very

abrasive depending on ore quality, and blinding can become a problem if the final separation is too small.

Metso solutions

For most pre-grinding applications, rubber media has the advantage. The primary screening side can be handled by Trellex MP in separations from 40 mm and up. Separations less than 40 mm will benefit from the

Trellex LS Modular system, available both in polyurethane and rubber. For the finer separations below 10-15 mm, a thin flexible membrane may be advisable to avoid blinding of screen surfaces due to feed humidity. Longitudinal slots are a common choice for optimizing throughput – particularly on “banana” screens.

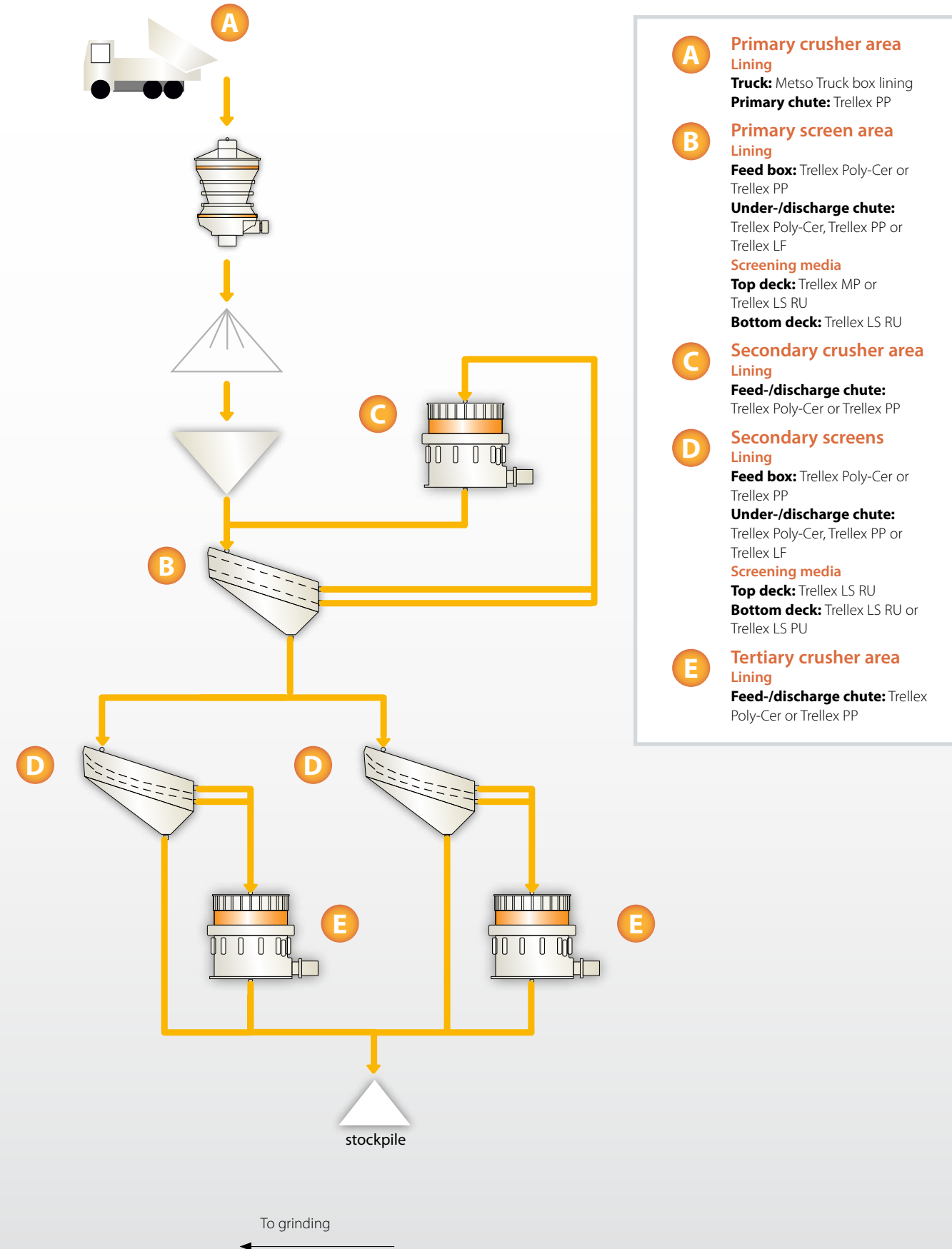

MINING: Crushing & screening

Pre-heap leach



Ore being prepared for heap leach goes through a crushing and screening process. The typically dry screening aims for separations ranging from 5-150 mm, with top size and size distribution optimized for leaching. Multi-slope screens are often set “banana”-style for handling high tonnages of fines throughput. The final screened product is stacked and protected by a sealed surface for collecting the leaching chemicals.

Challenges

The main challenge is pretty straightforward – to achieve high volume throughput of leach pad feed with as little downtime as possible. The leaching itself is the goal, and from a screening perspective, we simply want to minimize barriers to the feeding while ensuring our product is optimally sized for leaching. Flakiness can be a problem if the maximum feed size is

exceeded, even if it is not common. As with other ore screening processes, abrasion can become a problem depending on ore quality, and blinding is always an issue if the final separation is too small.

Metso solutions

Rubber screening media are a good choice for pre-heap leach. Trellex MP for separations of 40 mm and higher are

ideal for the primary screening side. For separations of less than 40 mm, the Trellex LS Modular system, available both in polyurethane and rubber, is a good choice. A thin flexible membrane could be advisable to avoid blinding of screen surfaces due to feed humidity at finer separations below 10-15 mm. Most operations opt for longitudinal slots in media to maximize throughput – particularly on banana screens.

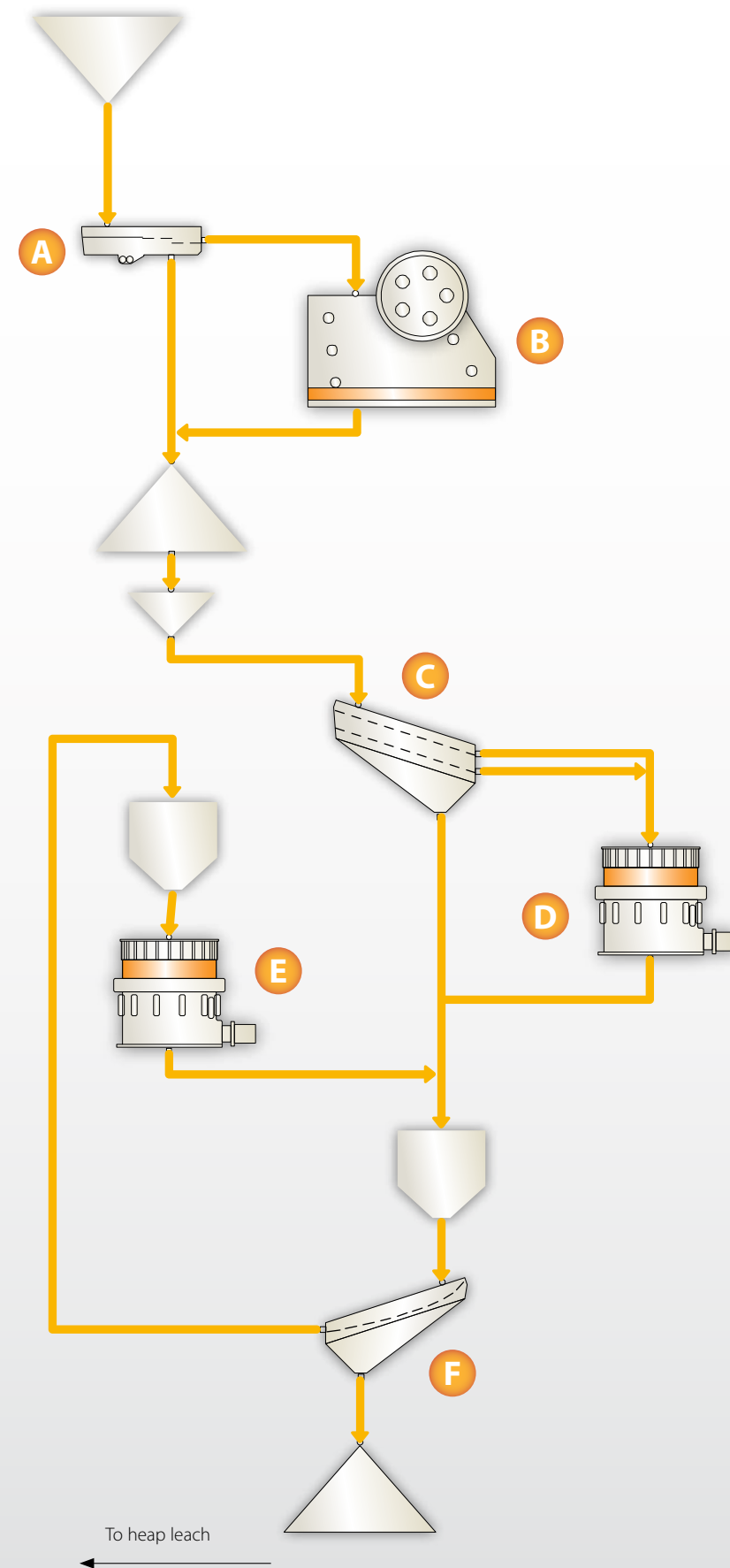

- A Feeder area**
Lining: Trellex Poly-Cer or Trellex PP
- B Primary crusher area**
Lining: Trellex Poly-Cer or Trellex PP
Feed-/discharge chute: Trellex Poly-Cer or Trellex PP
- C Scalping screen area**
Screening media
Top deck: Trellex MP (ceramic inserts as option)
Bottom deck: Trellex LS HiPer Life or Trellex LS Standard RU
Lining: Trellex Poly-Cer or Trellex PP
Feed box: Trellex Poly-Cer or Trellex PP
Under-/discharge chute: Trellex Poly-Cer or Trellex PP
- D Secondary crusher area**
Lining: Trellex Poly-Cer or Trellex PP
Feed-/discharge chute: Trellex Poly-Cer or Trellex PP
- E Tertiary crusher area**
Lining: Trellex Poly-Cer or Trellex PP
Feed-/discharge chute: Trellex Poly-Cer or Trellex PP
- F Closed circuit screen area**
Screening media
Top Deck: Trellex LS PU or/and Trellex LS HiPer Flow for low humidity material (< 3%), Trellex LS RU or LS HiPer Clean for material with higher humidity (> 3%) or when tendency of clogging
Lining: Trellex Poly-Cer or Trellex PP
Feed box: Trellex Poly-Cer or Trellex PP
Under-/discharge chute: Trellex Poly-Cer or Trellex PP

MINING: Crushing & screening

High grade ferrous ore



In iron ore mines where the iron grade is very high, ore can be produced without enrichment or beneficiation. Instead, rock is blasted, crushed and screened down to lump iron ore (typically 6-20 mm) or iron ore fines (0-6 mm), depending on the grade needed for its final use. Lump iron ore is often used directly in the steel making process, while fines are reserved for making sinter lumps.

Challenges

For screening media and lining applications, high-grade ferrous ore production can be challenging. Heavy raw material with sharp edges wears screening media down quickly and blinding can be an issue in finer separations. Coarser material flows are hard on linings, and with finer and/or wet separations, the problem can be compounded by flow problems. Linings also need closer monitoring for corrosion issues in wet applications. But despite these challenges, steel manufacturers are subject to compulsory screening accuracy requirements – quality expectations are high regardless of production issues.

Metso solutions

Generally speaking, this is rubber screen media territory because of the material's durability and flexibility. Primary screening can be handled by Trellex MP in separations from 40 mm and higher. Separations of less than 40 mm are probably better served by the Trellex LS Modular system, available both in polyurethane and rubber. For finer separations below 10-15 mm, a thin flexible membrane can help avoid blinding caused by feed humidity. If the build density is going to be very high, extra reinforced modules or panels are advisable. Most lining installations will consist of Trellex Poly-Cer, rubber modular systems, LF-system or a combination of the above.

The advantages of Metso screening media and lining over steel media and wear parts also include lower noise levels and improved working conditions.

Wet applications

Wet applications can take advantage of the same screening media. However, consider using STS* aperture patterns when the dewatering effect needs to be improved. If operation requires dedicated dewatering media, we recommend Trellex LS HiPer Drain for apertures under 1 mm and Trellex LS polyurethane for those exceeding over 1 mm. To protect against lining wear and corrosion, rubber or polyurethane solutions are recommended for normal applications. Trellex Poly-Cer is

*Slots across the screen direction

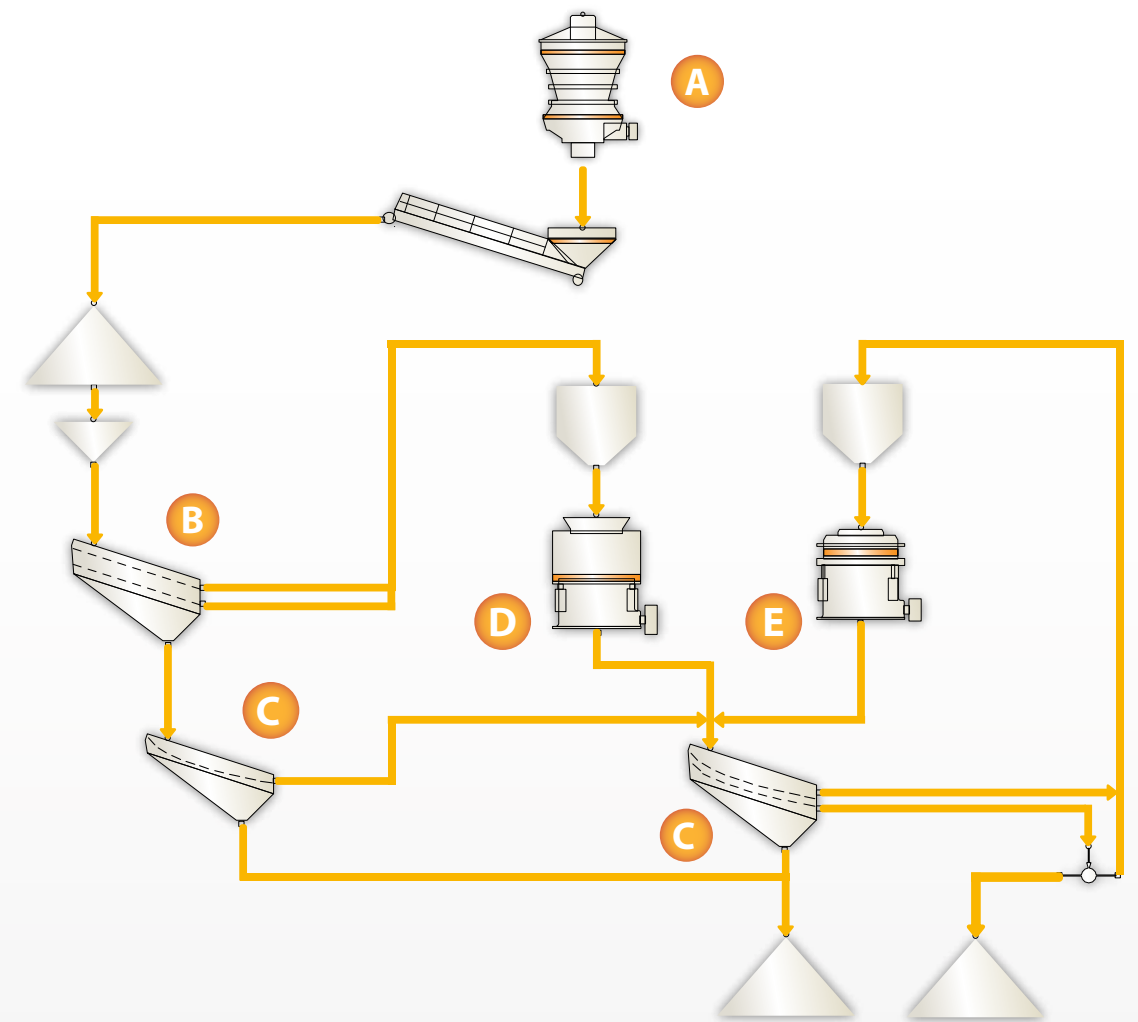

recommended for high capacity applications. If flow problems are anticipated, Trellex LF or Trellex Poly-Cer can help.

Good to know

In producing high grade iron ore, the challenge is ultimately to keep both production and strict final quality up. We can help you maximize your up-time with smart screening media and lining solutions, but there are a few things to keep in mind. For instance, consider alternative designs for the most critical wear areas such as modular or standardized liners, or dedicated lining package solutions that allow quick changes.

<p>A Primary crusher area Lining Primary chute: Trellex PP</p>	<p>B Primary screen area Screening media Top deck: Trellex MP (ceramic inserts as option, alternative Trellex PCO) Bottom deck: Trellex LS RU Lining Feed box: Trellex Poly-Cer Under chute: Trellex Poly-Cer Discharge chute: Trellex PP</p>	<p>C Final product screen area (secondary/tertiary) Screening media Top Deck: Trellex LS RU</p>	<p>D Secondary crusher area Lining Feed-/discharge chute: Trellex PP or Trellex Poly-Cer</p>	<p>E Tertiary crusher area Lining Feed-/discharge chute: Trellex PP or Trellex Poly-Cer</p>	<p>Bottom Deck: Trellex LS PU for humidity < 3 %, Trellex LS RU or Trellex LS HiPer Clean for humidity > 3 % Lining Feed box: Trellex Poly-Cer Undersize chute: Trellex Poly-Cer Discharge chute: Trellex PP</p>
--	---	---	--	---	---

MINING: Copper/Gold ore grinding

Mill discharge screens

This screening process, to control the top size of the final grinding ore, is set up at the discharge outlet of grinding mills. The objective is to remove oversized particles for further reduction to the optimal grinding size and any grinding balls or media. This is a wet screening process handled by trommel screens attached to the grinding mill or by separate horizontal vibrating screens, both single- and double-deck.

Challenges

Maximum throughput with as little downtime as possible is the goal, and this intensive process sees ore slurries being screened at very high tonnages. High abrasion and corrosion are natural by-products and are to be expected, which therefor demands planning for rugged screen body wear protection. The combined weight and surge forces of the

slurry make it imperative to plan for a heavy duty feed end with blind impact zone.

Metso solutions

These applications are predominantly polyurethane based. Slotted apertures and a rugged, heavy-duty design ensures that the media can handle the high tonnage throughput. Blind impact

zones in polyurethane or rubber are required. A combination of longitudinal transversal slots is best for dewatering, all depending on the percentage throughput. Sometimes protective decks are also applied – depending on the maximum lump size out of the mill. They can be in either rubber or polyurethane. In this case we usually recommend the Trellex LS modular system.

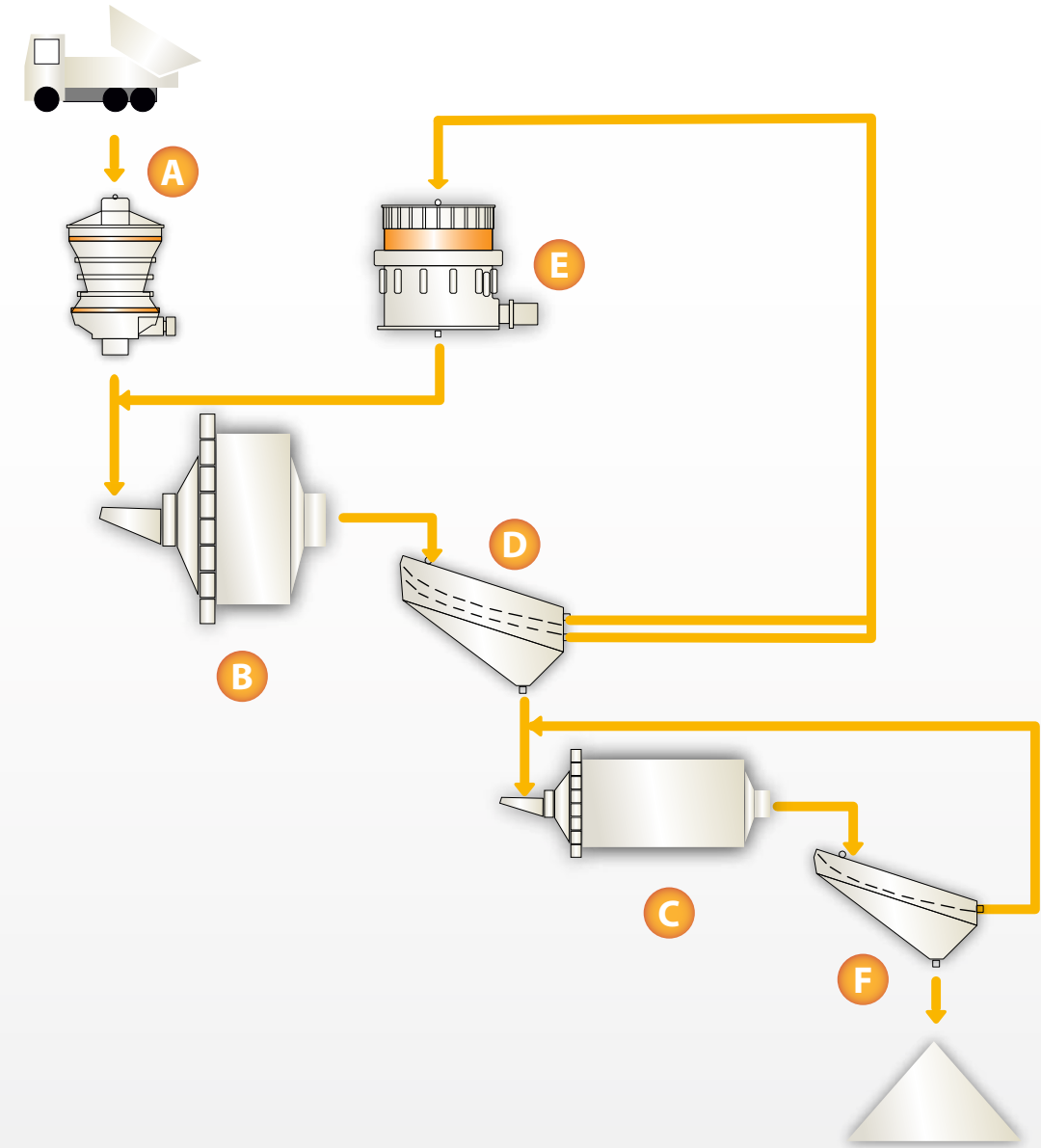

- A Primary crusher area**
Lining
Truck: Metso Truck box lining
Feed chute: Trellex PP
- B SAG Mill area**
Lining
Feed-/discharge chute, sump: Trellex Poly-Cer or Trellex PP
- C Secondary mill area**
Lining
Feed-/discharge chute, sump: Trellex Poly-Cer or Trellex PP
Channels: Trellex Poly-Cer or Trellex LF
- D SAG Mill discharge screen area**
Lining
Feed box: Trellex Poly-Cer or Trellex PP
Under-/discharge chute: Trellex PP, Trellex Poly-Cer or Trellex LF
Screening media
Top deck: Trellex MP, Trellex LS HiPer Life
Bottom deck: Trellex LS PU or Trellex LS RU (heavy duty reinforcement)
- E Secondary crusher area**
Lining
Feed-/discharge chute: Trellex PP
- F Sizing screen area**
Lining
Feed box: Trellex Poly-Cer or Trellex PP
Under-/discharge chute: Trellex PP or Trellex Poly-Cer
Screening media
Top deck: Trellex LS RU or Trellex LS PU

MINING: Beneficiation

Dense media circuits

Screening during beneficiation processes come with their own set of challenges, especially the pegging and blinding that can occur when handling smaller sizes with high moisture. Normally the goal is to recover material with no losses – while minimizing downtime to keep plant productivity high.

Desliming, DMS feed preparation

Desliming screens are used to maximize efficiency in DMS plants – coal preparation is a common example. Screening media must be capable of separating at between 0,5 and 1,4 mm while at the same time discharging an oversize with consistent surface moisture. One of the main concerns in these types of operations is to limit the loss of valuable material, for example in the case of diamond ore. Pegging of nearsize material should be planned for, as should corrosion from materials such as coal.

DMS sink/float

This screening process takes place in fluid media with a density between that

of the light and heavy fractions to be separated. The separation depends on density only. Lightweight particles such as coal float while heavy particles sink, making both recoverable. Naturally, high moisture and small fractions can lead to excessive pegging in screening media, holding operations up. Wear and tear when screening corrosive materials such as coal is also a common issue.

Dense media recovery

This is the screening process for removing dense media in the circuit, including magnetite or ferrosilicium. This is typically done on screen decks separating at 0,5 mm. Similar challenges have to be addressed in this process: pegging with nearsize material is not uncommon, and decks can get eaten

down quickly when handling corrosive materials.

Metso solutions

Because of the nature of these applications are screening media polyurethane based. We usually recommend the Trellex LS modular system, which is well-suited to these applications. The need for many small openings means apertures must be injection moulded, a specialty using proprietary technology in our own production plants to ensure maximum quality.

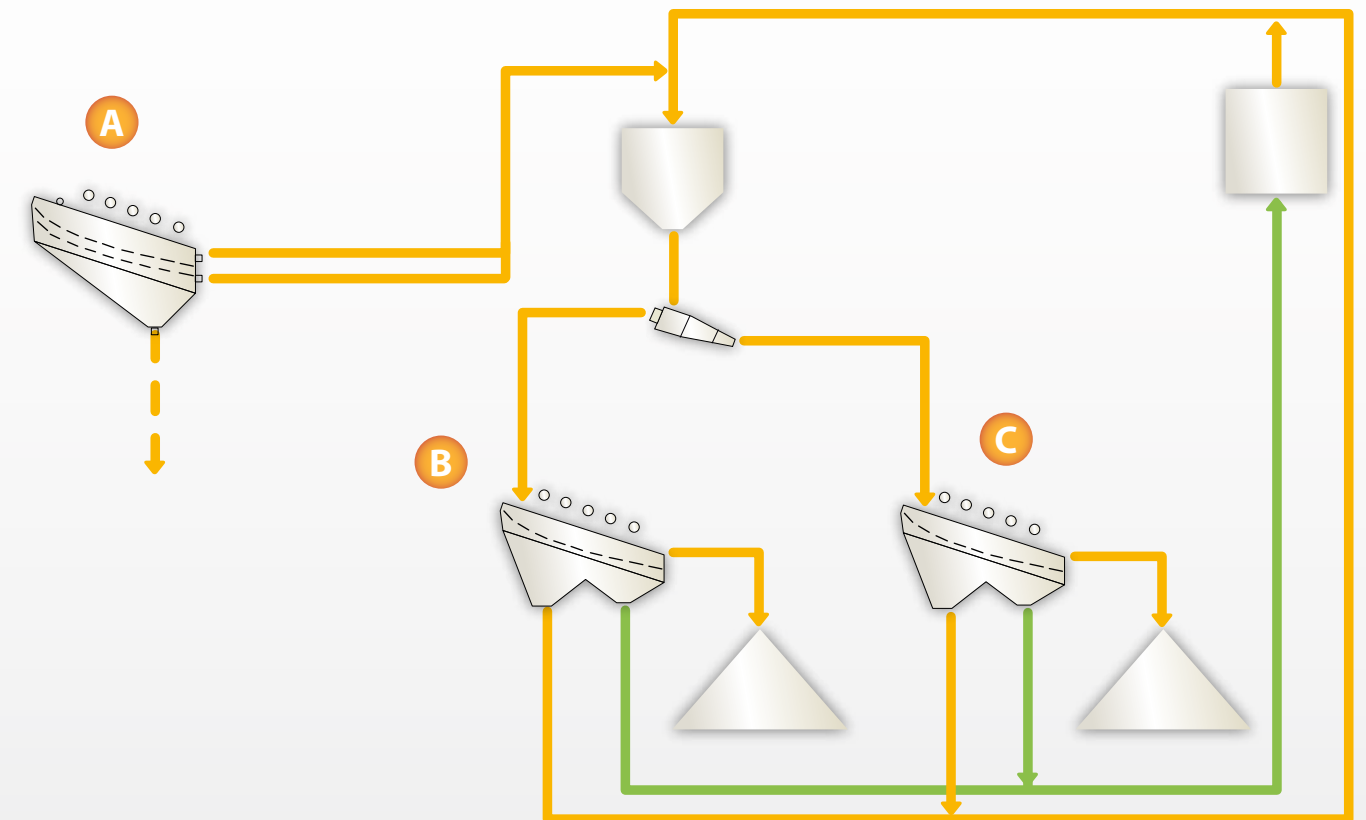

A Desliming screen area
Lining
Feed box: Trellex PP or Trellex Poly-Cer
Under-/discharge chute: Trellex PP or Trellex LF
Screening media
Top deck: Trellex LS PU
Bottom deck: Trellex LS PU

B Drain/rinse float screen area (Product screen)
Lining
Under-/discharge chute: Trellex PP, Trellex PPU or Trellex LF
Screening media
Top deck: Trellex LS PU or Trellex LS HiPer Drain

C Drain/rinse sink screen (Reject screen)
Lining
Under-/discharge chute: Trellex PP, Trellex PPU or Trellex LF
Screening media
Top deck: Trellex LS PU or Trellex LS HiPer Drain

MINING: Bulk handling

Control screening – fines removal



These plants are used for stocking, loading and unloading bulk materials such as coal, coke, lump iron ore, pellets, limestone and other commodities used by metal manufacturers or power plants. Regardless of the material, it is important to remove fines that could impact production further in the process prior to use.

Challenges

The main challenge is the weight and bed depth of the oversize. Special attention is usually needed for the screen media reinforcement structure to handle this. Also, some materials are prone to blinding, causing disruptions and unnecessary downtime if they're not planned for. Some materials, such as coke, can also be corrosive, eating away at decks more quickly and making it necessary to replace media more often.

Metso solutions

The selection of screening media surfaces is, to an extent, dictated by the

material being handled. Some materials may be hot, in which case rubber is typically the only option. Other materials such as iron ore pellets can be screened more efficiently with polyurethane cloths. Coke and lump iron ore, on the other hand, have a tendency to blinding, making rubber media a better option. Modular systems such as Trellex LS will usually get the job done, but for heavier applications Trellex MP becomes a better option.

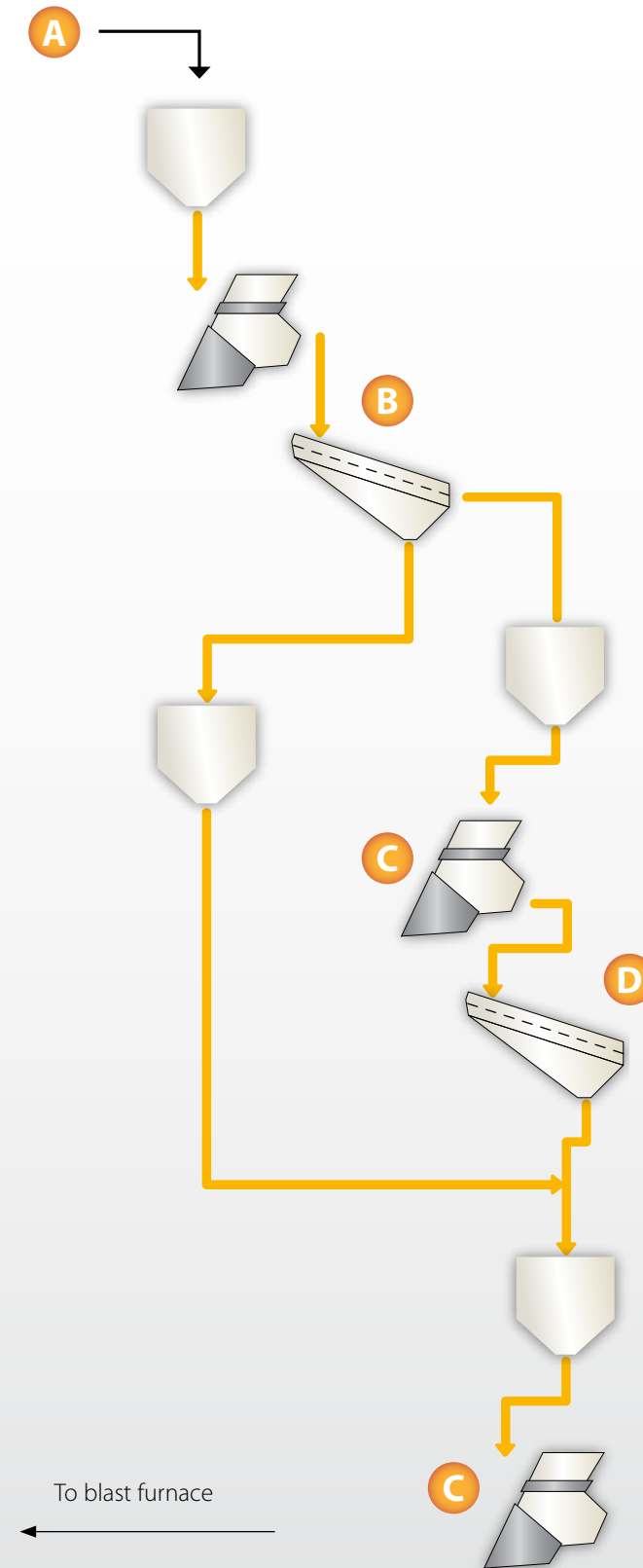

- A Stacker / reclaimer**
Lining
Transfer chute: Trellex Poly-Cer, Trellex PP or LF
- B Primary control screen area**
Lining
Feed box: Trellex Poly-Cer or Trellex PP
Under-/discharge chute: Trellex Poly-Cer or Trellex PP
Screening media
In order to remove dust and fines.
Top deck: Trellex LS RU or Trellex LS PU
- C Feeder area**
Lining
Trellex Poly-Cer or Trellex PP
- D Secondary control screen area**
Screening media
In order to remove dust and fines.
Top deck: Trellex LS RU or Trellex LS PU
Lining
Feed box: Trellex Poly-Cer or Trellex PP
Under-/discharge chute: Trellex Poly-Cer or Trellex PP

CONSTRUCTION

Soft rock

Soft rock screening usually applies to limestone. The goal is usually size reduction down to final products in fractions such as 2/4 and/or 4/6, in dry conditions. Wet processes are also fairly common. Working with soft rock is similar to hard rock from a processing point of view. In most cases, the same basic equipment is used, although possibly in a lighter version.

Challenges

The main challenge in soft rock screening is to avoid blinding due to high humidity in dry applications. Towards the finer separations, pegging can also be a serious problem. When separating the final product there can be requirements for screening accuracy subject to exacting standards by the customer or national regulatory bodies. Soft rock is normally not abrasive and is considered as a light material that causes very few impact problems.

Metso solutions

In primary screening applications for feed size over 200 mm, we recommend the Trellex MP/PCO system. In closed circuit and final product screening Trellex LS standard products make a good choice. In the finer separations, a thin and flexible rubber is recommended to avoid any blinding and pegging problems. In wet application polyurethane is generally recommended. Wear protection and lining is less common as abrasiveness is normally low for soft rock material. Trellex LF is recommended for use in

humid conditions to avoid sticky material to build up in chutes, bins, silos etc.

Existing installations

For existing installations, it is very common to see screens adapted for wire media. Trellex TCO is a strong option for longer life and less maintenance of screen decks. For applications showing pegging or blinding problems, Trellex TFX or Trellex PCL are two high performing options. If you're not sure, your Metso representative will be happy to make recommendations.



- A Primary feeder area**
Lining
Trellex PP or Trellex Poly-Cer
- B Natural fines screen area**
Screening media
Trellex PCO, Trellex PCL HD or Trellex CLS
- C Secondary screen area**
Lining
Feed box: Trellex PP or Trellex SQ or Trellex LF
Under chute: Trellex PP, Trellex SQ or Trellex LF
Discharge chute: Trellex PP or Trellex SQ
Screening media
Top deck: Trellex LS RU or Trellex PCL
Bottom decks: High humidity: Trellex LS HiPer Clean or Trellex PCL. Low humidity: Trellex LS PU
- D Final product screen area**
Lining
Feed box: Trellex PP or Trellex SQ
Under chute: Trellex PP, Trellex SQ or Trellex LF
Discharge chute: Trellex PP or Trellex SQ
Screening media
Top deck: Trellex LS HiPer Clean
Bottom decks: Trellex LS HiPer Clean or Trellex PCL
- E Tertiary crusher area**
Lining
Feed-/discharge chute: Trellex PP or Trellex SQ
- F Impact crusher area**
Lining
Feed-/discharge chute: Trellex PP or Trellex SQ
- G Secondary crusher area**
Lining
Feed-/discharge chute: Trellex PP or Trellex SQ

CONSTRUCTION

Hard rock

Hard rock screening is normally a dry process intended to secure final products for use in various construction applications such as roads, railways, and housing and civil engineering projects. It typically involves size reduction and production of final fractions. As you might expect, the material is abrasive and screens require wear protection and more durable media solutions compared to soft rock.

Challenges

Hard rock applications cover everything from medium to highly abrasive material. This means main challenge is avoiding unnecessary downtime due to impact and wear. Special attention needs to be paid to reinforcement. Harder materials also tend to have a more flaky or slab-like formation, resulting in problems with pegging. This is particularly common at finer separations under 16 mm. Thick screening media for maximum lifetime and managing impact can be too rigid to prevent pegging effectively. When planning the screen configuration, you

should also take into account lining and protection of structural parts of the equipment.

Metso solutions

The primary screening side can be effectively handled by Trellex MP/PCO in separations from 50 mm and higher. For separations of less than 50 mm, the Trellex LS Modular system, available both in polyurethane and rubber, is a good option. For the finer separations below 10-15 mm, a thin flexible membrane can help avoid the pegging due to flakiness of the material – Trellex LS standard or Trellex LS HiPer Clean

should be considered. At the feed end, thicker and more durable alternatives are recommended. Avoid a screen media deck layout with the screening area positioned directly over cross members and other structural parts of the screen.

Existing installations

Existing screens using wire cloth will benefit from using Trellex TCO to improve lifetime and reduce maintenance. At finer separations, the Trellex TFX option gives the highest possible screening accuracy with no pegging.

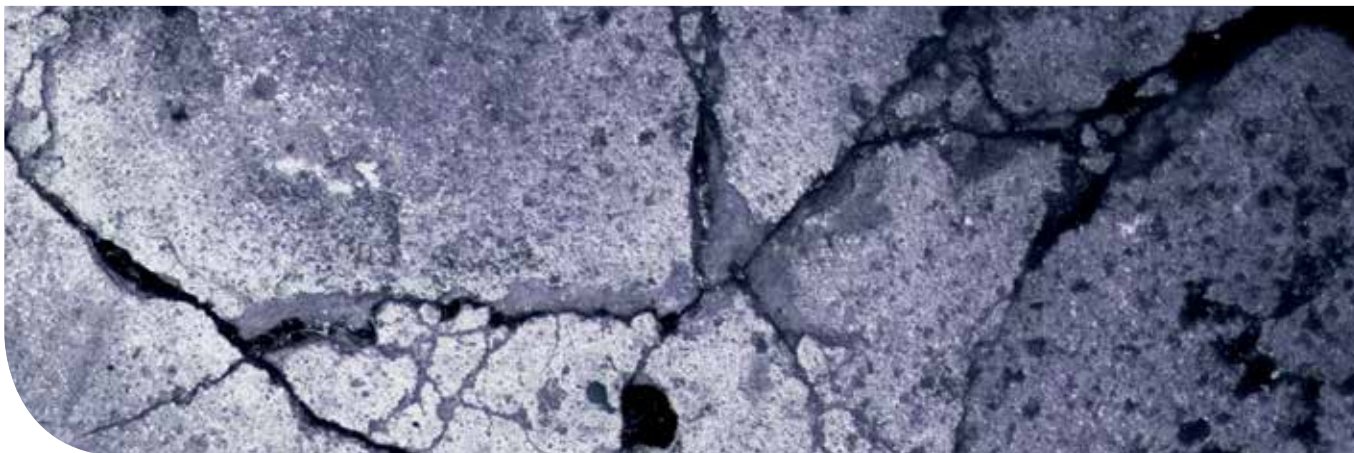
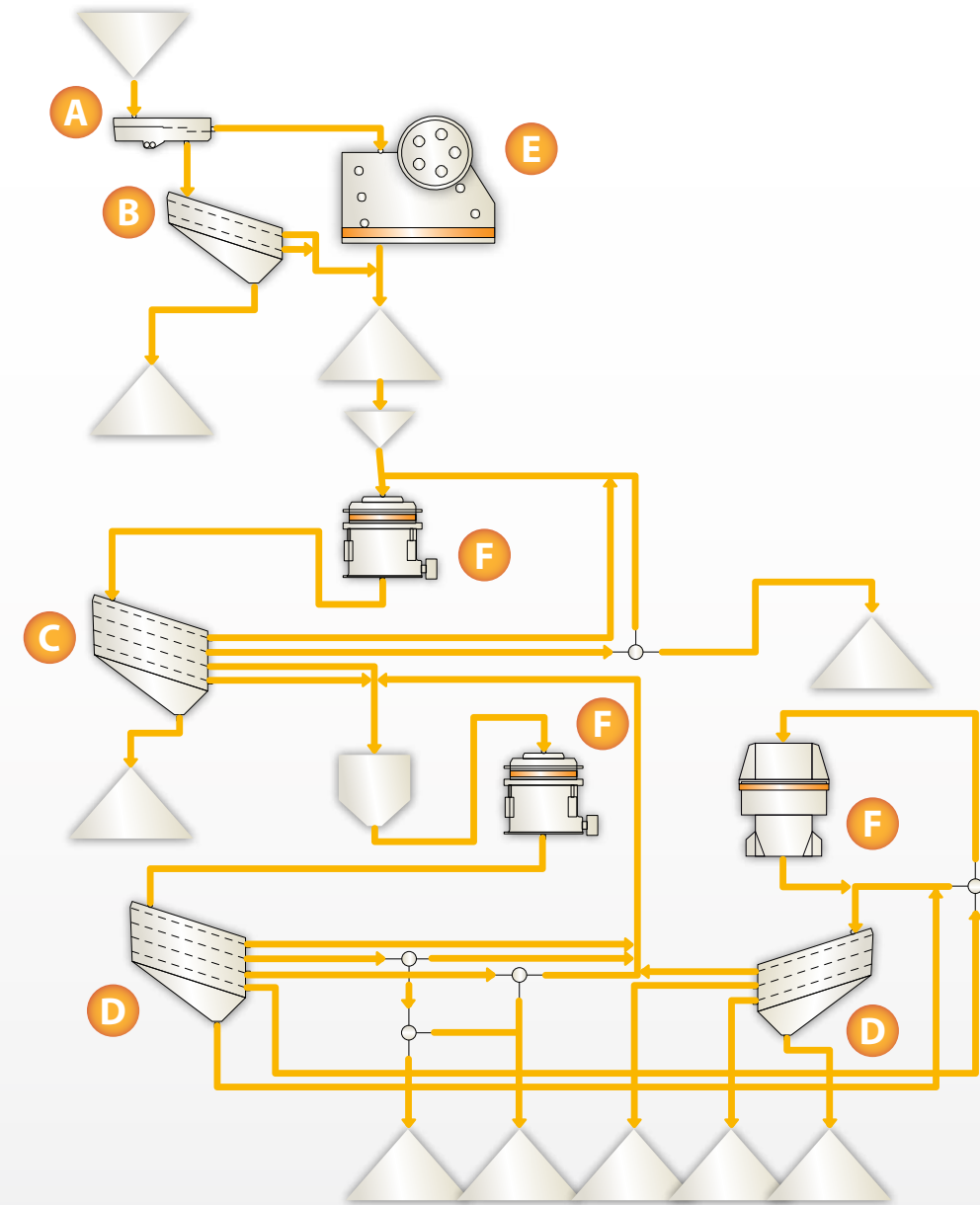

- A Primary feeder**
Lining: Trellex PP
- B Natural fines screen area**
Lining: Trellex PP and Trellex Poly-Cer
Feed box: Trellex PP and Trellex Poly-Cer
Under chute: Trellex PP and Trellex LF
Discharge chute: Trellex PP
Screening media: Trellex LS RU (HiPer Life option)
Top: Trellex LS RU (HiPer Clean option if high humidity)
Bottom: Trellex LS RU (HiPer Clean option if high humidity)
- C Secondary screen area**
Lining: Trellex PP, Trellex SQ or Trellex Poly-Cer
Feed box: Trellex PP, Trellex SQ or Trellex Poly-Cer
Under-/discharge chute: Trellex PP or Trellex SQ
Screening media: Trellex LS RU or Trellex PCL
Bottom decks: Trellex LS RU (Trellex LS PU option) or Trellex PCL. *If wet screening:* Trellex LS PU
- D Final product screen area**
Lining: Trellex LS RU, Trellex LS HiPer Clean or Trellex PCL.
Feed box: Trellex PP, Trellex SQ or Trellex Poly-Cer
Under-/discharge chute: Trellex PP or Trellex SQ
Screening media: Trellex LS RU, Trellex LS HiPer Clean or Trellex PCL.
If wet screening: Trellex LS PU
- E Impact crusher area**
Lining: Trellex PP or Trellex SQ
Feed-/discharge chute: Trellex PP or Trellex SQ
- F Crusher area**
Lining: Trellex PP or Trellex SQ
Feed-/discharge chute: Trellex PP or Trellex SQ

CONSTRUCTION

Sand and gravel



Sand and gravel are typically wet processes that involve dredging, scalping, sizing, washing or dewatering. In some markets, such as Scandinavia, it is more common for the material to be processed dry. Due to its round and smooth surface, sand is preferred as an aggregate in cement concrete when it is being pumped. Sand and gravel are obviously important to all forms of construction and their production is very common.

Challenges

Many sand and gravel plants in Western Europe and in many parts of the USA use screens without a feed box – the slurry box feeds directly onto the screening media. This requires strong screening media modules to resist the load from the slurry. Often the choice is polyurethane media, but this is also prone to the microbial attacks that are common to sand and gravel production – complementing the media with a microbial protection system is crucial. Another consideration in feed containing a high amount of sand is its

abrasiveness if wet. Sand-making usually requires some additional dewatering, requiring a bed depth of 200 mm or sometimes thicker. Strongly reinforced modules are needed to withstand the load.

Sometimes fine separations are made from feed material containing relatively large particle sizes (up to 150 mm). Again, strong screen media modules will be needed, along with a design adapted to handle fine separation. Some round materials also require slotted apertures in the screen direction to avoid the

material “rolling” over the screen deck.

Metso solutions

For scalping we recommend a strongly reinforced rubber or polyurethane module. Polyurethane has been traditionally marketed for use with water (wet processes), but rubber works just as well in scalping. For the finer separations we recommend Trellex LS standard or HD PU. Trellex LS RU is also an option. For dewatering of sand, we recommend Trellex LS HiPer Drain, designed to manage the load.

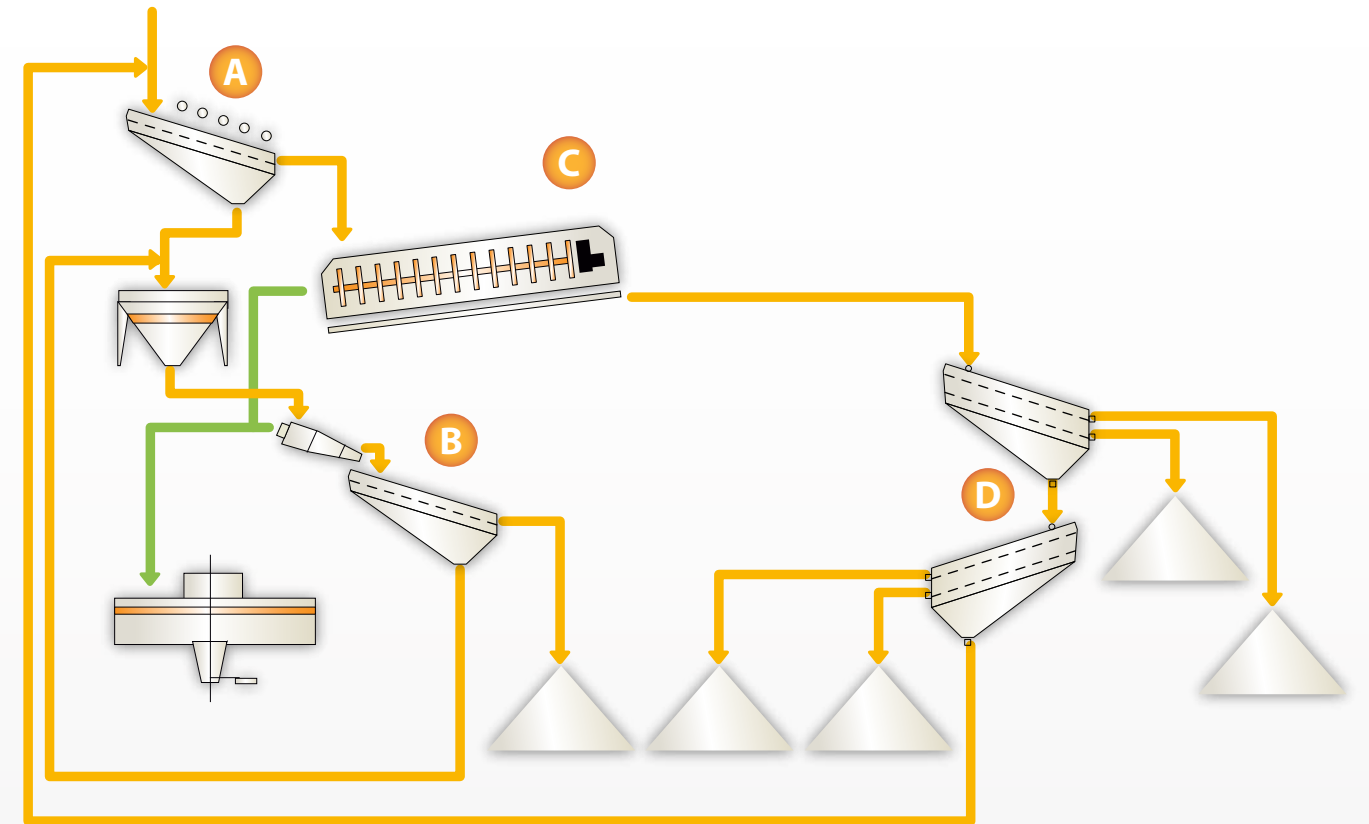

- A Washing screen area**
Lining
Slurry-/feed box: Trellex PP or Trellex PPU
Under-/discharge chute: Trellex PP, Trellex SQ or Trellex LF
Screening media
Top deck: Trellex LS PU
- B Dewatering screen area**
Lining
Feed box: Trellex PP
Under-/discharge chute: Trellex PP, Trellex SQ or Trellex LF
Screening media
Top deck: Trellex LS PU or Trellex LS HiPer Drain
- C Log washer area**
Lining
 Trellex PP or Trellex PPU
- D Final product screen area**
Lining
Feed box: Trellex PP
Under-/discharge chute: Trellex PP, Trellex SQ or Trellex LF
Screening media
Top deck: Trellex LS PU or Trellex PCL
Bottom deck: Trellex LS PU or Trellex PCL





Product
information

MODULAR SYSTEM

Modular system

The Trellex LS system is the result of more than 50 years of experience and development. This comprehensive modular system mounts lengthwise and is designed to fit virtually any screen, enabling higher volume processing with minimal interruptions.

The Trellex LS System is directly compatible with standard sub-frames used around the globe. The Trellex LS range is easily retrofitted to existing systems with no need to weld or cut steel rails. Several different profiled upgrade strips are included in the range to fit the majority of screens available on the market - simply fit them to the rail and then just add Trellex LS modules. In addition, several different sidelineer modules complement the side protection range.

The Trellex LS system has been designed for dependable operation, with lightweight rubber or polyurethane modules, easy snap-on connections and an emphasis on recyclability. A high open area for better performance was a key design issue during development

Simplified module selection

The Trellex LS modular system consists of Trellex LS standard range and Trellex LS HiPer range designed to accommodate requirements in various areas of

use: availability, capacity and non-blinding.

A complete Trellex LS range:

- Screen modules
- Sideliners/side wall protection
- Rails
- Upgrade strips
- Surface accessories

Trellex LS Standard

Trellex LS Standard range

Trellex LS is our platform for modular screening. Its success is based on securing a complete range that meets all your needs in terms of cost, availability, module sizes, functions and more.

The width and depth of our Trellex LS range means we can meet all your production challenges. Our unique use of various materials coupled with modern and efficient production technologies creates solutions and opportunities that deliver on your high expectations.

Polyurethane modules are manufactured from open cast technology, predominantly with a dual hardness design for maximum life and performance. Injection-molded TPU for highest possible precision is also available.

Injection-molded wear-resistant rubber ensures consistent material performance properties in all rubber modules. Choose between punched or molded apertures. The Trellex LS system also includes a wide range of accessories for more effective throughput of fines.

Trellex LS modules help you max the volume while minimizing the downtime. Thanks to the industry's only true global sales and support network, Trellex LS modules are always available quickly and conveniently wherever you are. Make sure your screen is always producing at its cost-effective best. Match it with Trellex LS screening modules.

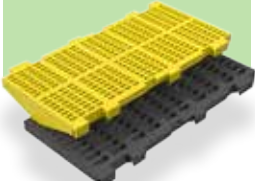
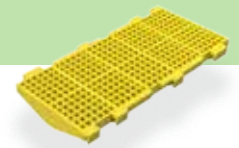
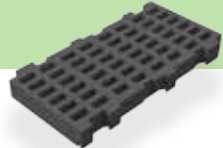
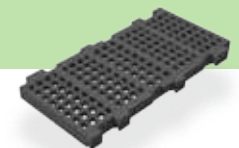
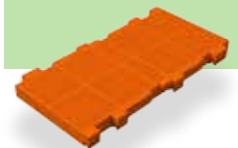
Availability	Capacity	Lifetime, durability	Non-pegging, non-blinding	Precision, efficiency
Trellex LS standard range Always available, quickly and conveniently wherever you are	Trellex LS HiPer Flow At least 20% more active screening surface	Trellex LS HiPer Life Built tough for maximum load handling	Trellex LS HiPer Clean Precision production without interruptions, guaranteed to stay clean	Trellex LS HiPer Drain Precision and exceptional dewatering
				

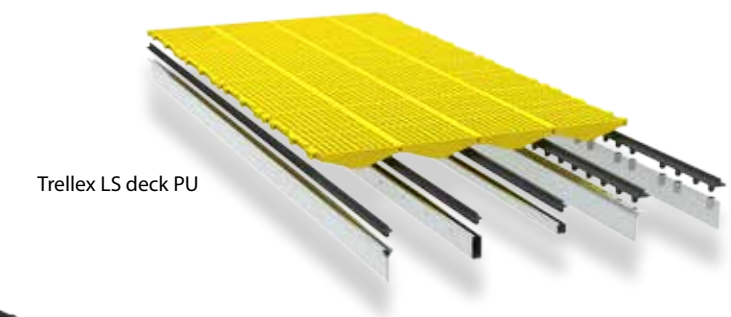

Trellex LS deck PU



Trellex LS deck RU

Trellex LS PU Standard

Trellex 300LS-500

Available molded square apertures (FR)

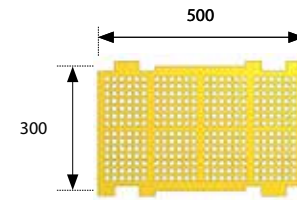

Hole type	Module weight (kg)	Thickness screen area (mm)	Quantity apertures per panel	Relative open area (%)	Effective open area (%)	Min web thickness with flow (mm)	Min web thickness cross flow (mm)	Build height (mm)	Part No. 75/90 (Sh-D/Sh-A)	Part No. 75/80 (Sh-D/Sh-A)
FR2.5	2.94	6	3024	20.1	12.6	3	3	30	ZX11223793	MM0366167
FR3	2.41	4	3168	29.8	19.0	2.5	2.5	30	6680303	6681056
FR3HD	2.83	6	2160	21.3	13.0	3.5	3.5	30	6680305	6680305.78
FR3.5	2.29	5	2584	31.9	21.1	2.5	2.9	30	6680083	6680083.78
FR4	2.51	5	2160	36.7	23.0	2.6	2.6	30	6680307	6680307.78
FR5	2.51	5	1560	44.2	26.0	2.7	2.7	30	6680308	6680308.78
FR5HD	2.93	9	1144	30.9	19.1	4	4	30	6680309	6680309.78
FR5.5	2.78	7	1144	37.3	23.1	3.5	3.5	30	6680310	6680310.80
FR5.5HD	3.72	12	960	33.5	19.4	4	4	40	6681243	6681242
FR6	2.44	6	1144	40.7	27.5	3.4	3.4	30	6680084	6680084.78
FR6HD	3.06	10	792	29.8	19.0	5	5	30	6680311	
FR6.5	2.56	6	960	42.3	27.0	3.5	3.5	30	6680821	6680821.78
FR6.5HD	3.86	14	720	34.9	20.3	4.5	4.5	40	6681247	6681246
FR7	2.4	6	960	47.1	31.4	3.2	3.2	30	6680115	6680115.78
FR8	2.42	9	720	44.1	30.7	3.6	4.5	30	6680082	6681158
FR9	2.54	9	576	44.5	31.1	4	5	30	6680080	6680080.78
FR9HD	3.51	20	336	23.7	18.1	10	9	30	6680724	6680724.78
FR10	2.56	10	448	44.4	29.9	5	5	30	6680078	6681401.80
FR11	2.61	10	384	45.9	31.0	6	4.5	30		6680079
FR12	2.75	12	336	44.4	32.3	6	6	30		6660584
FR13	2.67	12	288	44.2	32.4	5.2	8	30		6680081
FR13HD	3.49	25	240	34.9	26.6	8.5	9.5	30		MM0345335
FR14	2.91	15	240	40.5	31.4	8	8	30		6680313
FR15	2.73	15	240	46.5	36.0	7	7	30		6680314
FR16	2.71	20	220	50.6	37.5	6.5	6.5	30		6680315
FR17	2.83	20	200	44.5	34.7	8	9	30		6680316
FR18	3.23	20	144	41.3	31.1	10	10	30		6680317
FR19	2.95	20	144	44.4	34.7	9.5	9.5	30		6680318
FR20	2.73	20	144	49.2	38.4	8.5	8.5	30		6680319
FR21	3.22	20	128	43.1	32.9	11	11	30		6680320
FR22	2.94	20	128	45.8	36.1	10	11	30		6680321
FR23	2.75	20	128	50.1	39.5	9.5	9.5	30		6680322
FR24	3.24	25	91	44.4	34.9	12	12	30		6680323
FR25	3.05	25	91	48.2	37.9	11	11	30		6680144
FR26	3.23	25	84	49.4	37.9	10	12	30		6680815
FR27	3.05	30	84	53.0	40.8	9	12	30		6680856
FR28	3.58	30	66	41.9	34.5	15.5	15	30		6680858
FR36	3.63	25	45	46.1	38.9	17	17	40		6680085
FR36	3.2	25	45	46.1	38.9	17	17	30		6680100
FR44	4.36	30	28	39.5	36.1	25	27	30		MM0365907

Other apertures on request.

Trellex LS PU Standard

Trellex 300LS-610

Available molded square apertures (FR)

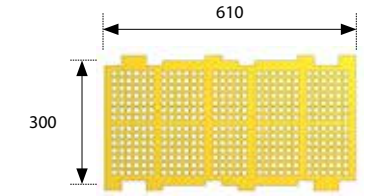

Hole type	Module weight (kg)	Thickness screen area (mm)	Quantity apertures per panel	Relative open area (%)	Effective open area (%)	Min web thickness with flow (mm)	Min web thickness cross flow (mm)	Build height (mm)	Part No. 75/90 (Sh-D/Sh-A)	Part No. 75/80 (Sh-D/Sh-A)
FR2.5	3.54	6	3696	20.1	12.5	3	3	30	MM0366165	MM0366166
FR3	2.92	4	3872	29.8	19.0	2.5	2.5	30	6680353	
FR3HD	3.45	6	2628	21.3	12.9	3.5	3.5	30	6680367	
FR3.5	2.77	5	3154	31.9	21.1	2.5	2.9	30	6680349	
FR4	2.98	5	2664	36.7	23.3	2.6	2.6	30	6680351	
FR5	3.1	5	1890	42.2	25.8	2.7	2.7	30	6680352	ZX11194445
FR5HD	3.54	9	1404	30.9	19.2	4	4	30	6680368	
FR5.5	3.34	7	1404	37.3	23.2	3.5	3.5	30	6680370	6680370.78
FR5.5HD	4.82	12	1176	33.5	19.4	4	4	40	6681259	6681258
FR6	2.91	6	1404	40.7	27.6	3.4	3.4	30	6680350	ZX11213870
FR6HD	3.71	10	968	29.8	19.0	5	5	30	6680369	
FR6.5	3.08	6	1176	42.3	27.2	3.5	3.5	30	6680519	
FR6.5HD	4.72	14	880	34.9	20.3	4.5	4.5	40	6681263	6681262
FR7	2.88	6	1176	47.1	31.5	3.2	3.2	30	6680354	
FR8	2.95	9	880	44.1	30.8	3.6	4.5	30	6680348	6680348.78
FR9	3.09	9	702	44.5	31.1	4	5	30	6680346	
FR9HD	4.34	20	406	23.7	18.0	10	9	30	6680725	
FR10	3.14	10	672	44.4	29.7	5	5	30	6680344	
FR11	3.19	10	464	45.9	30.7	6	4.5	30		6680345
FR12	3.42	12	406	44.4	31.9	6	6	30		6680301
FR13	3.29	12	348	44.2	32.1	5.2	8	30		6680347
FR13HD	4.34	25	288	34.9	26.6	8.5	9.5	30		6681640
FR14	3.61	15	288	42.4	30.8	8	8	30		6680355
FR15	3.38	15	288	46.5	35.4	7	7	30		6680356
FR16	3.38	20	264	50.6	36.9	6.5	6.5	30		6680357
FR17	3.44	20	220	44.5	34.7	8	9	30		6680358
FR18	4.02	20	171	41.3	30.3	10	10	30		6680359
FR19	3.68	20	171	44.4	33.7	9.5	9.5	30		6680360
FR20	3.41	20	171	49.2	37.4	8.5	8.5	30		6680361
FR21	3.92	20	136	43.1	32.8	11	11	30		6680363
FR22	3.6	20	136	45.8	36.0	11	10	30		6680364
FR23	3.36	20	136	50.1	39.3	9.5	9.5	30		6680362
FR24	3.91	25	112	44.4	35.3	12	12	30		6680365
FR25	3.8	25	105	44.5	35.9	14	11	30		6680366
FR26	3.8	25	105	52.2	38.8	10	12	30		6680894
FR27	3.99	30	98	50.6	39.0	13	9	30		6680670
FR28	4.13	30	84	42.9	36.0	15.5	14	30		6680859
FR32	4.12	25	72	47.5	40.3	17	12	40		6680522
FR37	4.46	30	55	47.0	41.1	17.5	16.5	40		6681032

Other apertures on request.

Trellex LS PU Standard

Trellex 305LS-610

Available molded square apertures (FR)

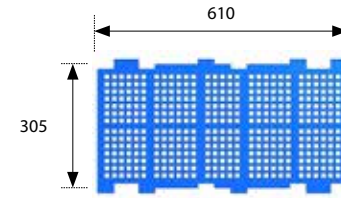

Hole type	Module weight (kg)	Thickness screen area (mm)	Quantity apertures per panel	Relative open area (%)	Effective open area (%)	Min web thickness with flow (mm)	Min web thickness cross flow (mm)	Build height (mm)	Part No. 75/90 (Sh-D/Sh-A)	Part No. 75/80 (Sh-D/Sh-A)
FR2.5	3.65	6	3696	20.1	12.4	3	3	30		MM0374463
FR3	3.03	4	3872	29.8	18.7	2.5	2.5	30	6680830	ZX11208628
FR3HD	3.56	6	2628	21.3	12.7	3.5	3.5	30	6680831	
FR3.5	2.88	5	3154	31.9	20.8	2.5	2.9	30	6680489	MM0400764
FR4	3.09	5	2664	36.7	22.9	2.6	2.6	30	6680832	
FR5	3.21	5	1890	42.2	25.4	2.7	2.7	30	6680490	
FR5HD	3.65	9	1404	30.9	18.9	4	4	30	6680571	
FR5.5	3.45	7	1404	37.3	22.8	3.5	3.5	30	6680833	
FR5.5HD	4.63	12	1176	33.5	19.4	4	4	40	6681192.90	6681192.78
FR6	3.03	6	1404	40.7	27.1	3.4	3.4	30	6680834	6680834.78
FR6HD	3.82	10	968	29.8	18.7	5	5	30	6680893	
FR6.5	3.19	6	1176	42.3	26.7	3.5	3.5	30	6680491	MM0400761
FR6.5HD	4.87	14	880	34.9	20.3	4.5	4.5	40	6681193.90	6681193.78
FR7	2.99	6	1176	47.1	31.0	3.2	3.2	30	6680835	
FR8	3.06	9	880	44.1	30.3	3.6	4.5	30	6680492	6680492.78
FR9	3.2	9	702	44.5	30.6	4	5	30	6680836	
FR9HD	4.45	20	406	23.7	17.7	10	9	30	6680847	
FR10	3.25	10	672	44.4	29.2	5	5	30	6680493	
FR11	3.3	10	464	45.9	30.2	6	4.5	30		6680837
FR12	3.53	12	406	44.4	31.4	6	6	30		6680854
FR13	3.4	12	348	44.2	31.6	5.2	8	30		6680494
FR13HD	4.45	25	288	34.9	26.2	8.5	9.5	30		6681613
FR14	3.72	15	288	42.4	30.3	8	8	30		6680838
FR15	3.49	15	288	46.5	34.8	7	7	30		6680839
FR16	3.49	20	264	50.6	36.3	6.5	6.5	30		6680495
FR17	3.55	20	220	44.5	34.1	8	9	30		6680840
FR18	4.13	20	171	41.3	29.8	10	10	30		6680841
FR19	3.79	20	171	44.4	33.1	9.5	9.5	30		6680842
FR20	3.52	20	171	49.2	36.8	8.5	8.5	30		6680496
FR21	4.03	20	136	43.1	32.3	11	11	30		6680843
FR22	3.71	20	136	45.8	35.4	11	10	30		6680844
FR23	3.47	20	136	50.1	38.7	9.5	9.5	30		6680606
FR24	4.02	25	112	44.4	34.7	12	12	30		6680845
FR25	3.91	25	105	44.5	35.3	14	11	30		6680497
FR26	3.91	25	105	52.2	38.2	10	12	30		6680895
FR27	4.1	30	98	50.6	38.4	13	9	30		6680625
FR28	4.24	30	84	42.9	35.4	15.5	14	30		6680891
FR32	4.26	25	72	47.5	39.6	17	12	40		6680500
FR37	4.61	30	55	47.0	40.5	17.5	16.5	40		6681054

Non standard

Other apertures on request.



Maximize the output while minimizing the downtime

Trellex LS PU Standard

Trellex 300LS-500

Available molded slotted apertures (SLS/STS)

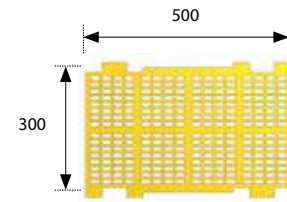

Hole type	Module weight (kg)	Thickness screen area (mm)	Quantity apertures per panel	Relative open area (%)	Effective open area (%)	Min web thickness with flow (mm)	Min web thickness cross flow (mm)	Build height (mm)	Part No. 75/90 (Sh-D/Sh-A)	Part No. 75/80 (Sh-D/Sh-A)
SLS 0.63x12	3.12	8	1536	13.0	7.7	4	3	30	6680817	
SLS0.8x12	2.95	8	1392	12.5	8.8	5.5	3.3	30		6681479
SLS 1x13	2.78	6	1440	19.6	12.5	3.5	3	30	6680818	
SLS 1x17	3.25	15	1040	16.1	11.8	5	3.8	30	6681448	MM0379677
SLS 1.4x20	2.54	14	1160	26.9	21.6	3.1	3.1	30		MM0357301
SLS 1.5x12	2.83	7	1152	20.6	13.8	5.5	3.5	30	6680819	
SLS 1.6x19	2.7	15	1040	26.1	21.0	3.45	4.1	30		MM0345179
SLS 1.6x20	2.13	8	1160	31.0	24.8	2.9	2.9	30		MM0345177
SLS 2x12	2.98	8	1008	24.9	16.1	5.5	3.5	30	6680820	6680820.78
SLS 2.5x12	3.0	10	864	26.4	17.3	5.5	4	30	6681332	ZX11156538
SLS 3x22	3.0	16	576	33.7	25.3	4	6	30		MM0345472
SLS 4x15	3.02	12	600	34.1	24.0	7	4	30	6680709	MM0359644
SLS 4x22	2.84	16	512	39.3	30.0	4	6	30		MM0345176
SLS 5x15	3.05	12	520	37.9	26.0	7	4	30		6681347
SLS 5x26	3.35	20	288	30.8	25.0	13.5	5.7	30		MM0345336
SLS 6x20HD	3.32	20	320	35.7	25.6	8	6	30	6680822	
SLS 7x32	2.79	20	240	45.3	35.8	6	6	30		MM0345337
SLS8x27.5		30	192	35.9	28.2	8.3	10	40		
SLS 9x13	2.7	12	432	47.6	33.7	4.8	4.8	30		6680933
SLS 10x22	2.94	20	256	49.1	37.5	6	6	30		6681649
SLS 12x27.5		30	192	35.9	28.2	8.3	10	40		
STS 0.63x12	2.66	8	1664	11.8	8.4	3.5	3.5	30	MM0373922	6681027.78
STS 0.8x12	3.43	8	1456	14.0	9.3	3	6	30	6680786	6681107
STS 1x12HD	3.7	10	952	11.8	7.6	5	5	40	6680769	6680769.78
STS 1.5x12	2.94	7	1232	23.5	14.8	3	5	30	6680584	6680584.78
STS 2x12	2.89	8	840	18.5	13.4	5	6	30	6681301	
STS 2.5x12	3.57	20	728	46.9	14.7	5.5	5.5	30	ZX11277712	6681099
STS 2.5x25HD	5.2	30	252	14.2	10.5	10	10	40	MM0358109	
STS 3x12	3.62	20	672	24.2	16.1	5.5	8	30	6680719.90	6680719
STS 3x20	3.86	15	520	28.8	18.6	8	5	40		MM0420115
STS 4x15	2.91	6	672	40.8	26.8	3	6	30	6680776	
STS 4x15	3.3	20	528	30.8	21.1	5.5	5.5	30		6681302
STS 5x25	3.17	20	320	35.0	26.7	8	6	30	6681036.90	6681036
STS 8x25	3.78	20	224	29.9	43.8	6.5	6.5	40		6680973
STS 10x40	3.63	30	96+48	43.0	32.5	10	9.5	40		
STS 11x25	3.63	30	192	45.2	35.2	7	8	30		6681546

Other apertures on request.

Trellex LS PU Dewatering 300LS-500

Hole type	Module weight (kg)	Thickness screen area (mm)	Quantity apertures per panel	Relative open area (%)	Effective open area (%)	Min web thickness with flow (mm)	Min web thickness cross flow (mm)	Build height (mm)	Part No. 75/90 (Sh-D/Sh-A)
SLS0.3x11.5	4.9	8	2016	7.7	4.6	2.9	2.6	40	MM0391753
SLS0.4x12.4	4.8	8	2016	11.6	6.7	2.7	1.4	40	MM0399115
SLS0.5x12.5	4.8	8	1904	13.7	7.9	2.8	1.3	40	MM0399128
SLS0.63x12	4.9	8	1792	15.4	9.5	2.9	1.9	40	MM0399133
SLS0.8x12	4.8	8	1792	18.7	11.5	2.7	1.9	40	MM0399139
SLS0.3x11.5 - HD*	5.9	8	1728	7.7	4.0	2.9	2.6	40	
SLS0.4x12.4 - HD*	5.9	8	1728	11.6	5.7	2.7	1.4	40	
SLS0.5x12.5 - HD*	5.9	8	1632	13.7	6.8	2.8	1.3	40	MM0381839
SLS0.63x12 - HD*	5.9	8	1536	15.4	7.7	2.9	1.9	40	
SLS0.8x12 - HD*	5.9	8	1536	18.7	9.8	2.7	1.9	40	
STS0.3x11.5	4.9	8	2016	7.7	4.6	2.6	2.9	40	MM0399109
STS0.4x12.4	4.8	8	2016	11.6	6.7	1.4	2.7	40	MM0399120
STS0.5x12.5	4.8	8	1904	13.7	7.9	1.3	2.8	40	MM0399130
STS0.63x12	4.9	8	1792	15.4	9.5	1.9	2.9	40	MM0399136
STS0.8x12	4.8	8	1792	18.7	11.5	1.9	2.7	40	MM0399144
STS0.3x11.5 - HD*	5.9	8	1728	7.7	4.0	2.6	2.9	40	MM0373697
STS0.4x12.4 - HD*	5.9	8	1728	11.6	5.7	1.4	2.7	40	
STS0.5x12.5 - HD*	5.9	8	1632	13.7	6.8	1.3	2.8	40	MM0381840
STS0.63x12 - HD*	5.9	8	1536	15.4	7.7	1.9	2.9	40	
STS0.8x12 - HD*	5.9	8	1536	18.7	9.8	1.9	2.7	40	

* HD = Heavy Duty with ability to carry 200-300mm bed depth depending on slurry density

** Injection moulded openings cast into module

SLS = With flow, STS = Cross flow

Trellex LS PU Standard

Trellex 300LS-610

Available molded slotted apertures (SLS/STS)

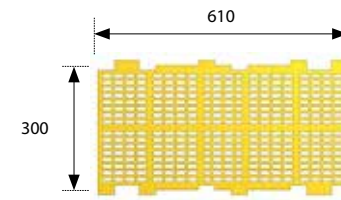

Hole type	Module weight (kg)	Thickness screen area (mm)	Quantity apertures per panel	Relative open area (%)	Effective open area (%)	Min web thickness with flow (mm)	Min web thickness cross flow (mm)	Build height (mm)	Part No. 75/90 (Sh-D/Sh-A)	Part No. 75/80 (Sh-D/Sh-A)
SLS 0.63x12	3.82	8	1914	13.0	7.7	4	3	30	6680633	
SLS 0.8x12	3.65	8	1682	12.5	8.8	5.5	3.3	30	6681450	
SLS 1x13	3.41	6	1740	19.7	12.4	3.5	3	30	6680523	
SLS 1x17	4.1	15	1248	16.1	11.6	5	3.8	30		MM0357310
SLS 1.4x20	3.17	14	1392	26.9	21.5	3.1	3.1	30		MM0357303
SLS 1.5x12	3.51	7	1392	20.6	13.7	5.5	3.5	30	6680524	
SLS 1.6x19	3.4	15	1248	26.1	20.7	3.45	4.1	30		MM0345180
SLS 1.6x20	2.66	8	1392	31.0	24.5	2.9	2.9	30		MM0345178
SLS 2x12	3.68	8	1218	24.9	16.0	5.5	3.5	30	6680525	
SLS 2.5x12	3.7	10	1044	26.4	17.1	5.5	4	30		6681580
SLS 4x15	3.79	12	720	34.1	23.6	7	4	30	6680710	
SLS 3x22	3.6	16	720	33.7	25.5	4	6	30		MM0345471
SLS 4x22	3.39	16	640	39.3	30.2	4	6	30		6681641
SLS 5x15	3.82	12	624	37.9	25.6	7	4	30		6681632
SLS 5x26	4.11	20	360	30.8	25.1	13.5	5.7	30		6681631
SLS 6x20HD	4.18	20	380	35.7	24.9	8	6	30	6680828	
SLS 7x32	3.39	20	300	45.3	35.8	6	6	30	MM0377879	6681630
SLS 8x27.5	4.85	30	240	36.0	27.9	8.3	10	40		MM0379064
SLS 8x56	3.79	20	144	41.0	35.3	6.4	19.5	30		6681642
SLS 9x13	3.38	12	522	47.6	33.4	4.8	4.8	30	6680993	6680993.78
SLS 10x22	3.59	20	320	45.3	35.8	6	6	30	6681453	6681453.80
SLS 12x25	3.63	20	180	34.9	29.5	10	14	30		6681369
SLS 12x27.5	4.8	30	180	39.0	30.9	10	10	40		MM0369327
SLS 12x50	3.36	20	108	41.3	35.4	10	16	30		6681629
SLS 14x25	3.07	15	180	41.4	34.4	14	7.7	30		6681293
SLS 16.7x25	4.26	30	160	46.4	36.4	10	9	40		6680338.78
SLS 19x51.5	4.03	30	81	56.8	43.3	9	10	40		6680339.78
SLS 25x48	4.17	30	63	47.3	41.3	17	14	40		6680972
SLS 26x32	4.5	30	84	47.2	38.2	10	17	40		6681139
SLS 30x58	4.19	30	48	53.0	45.6	15	15	40		
SLS 37x57	4.29	40	40	51.6	46.1	17.5	18	40		
SLS 37x112	6.39	40	16	39.2	36.2	35.7	33.5	40		
STS 0.63x12	3.26	30	2016	11.8	8.3	3.5	3.5	30	6681207	
STS 0.8x12	4.21	8	1764	14.0	9.3	3	6	30	6680823	

Table continues on next page →

Hole type	Module weight (kg)	Thickness screen area (mm)	Quantity apertures per panel	Relative open area (%)	Effective open area (%)	Min web thickness with flow (mm)	Min web thickness cross flow (mm)	Build height (mm)	Part No. 75/90 (Sh-D/Sh-A)	Part No. 75/80 (Sh-D/Sh-A)
STS 1x12HD	4.58	10	1148	11.8	7.5	5	5	40	6680824	
STS 1.5x12	3.59	7	1498	23.5	14.74	3	5	30	6680825	
STS 2x12	3.45	8	1036	18.5	13.6	5	7	30	MM0371618	6681627
STS 2.5x12	4.33	20	896	46.9	14.7	5.5	5.5	30		6681397
STS 2.5x25HD	5.5	30	315	14.2	10.5	10	10	40	MM0358108	
STS 3x12HD	4.36	20	826	24.2	16.2	5.5	8	30	6680826	ZX11190619
STS 3x20	4.63	15	640	28.8	17.9	8	5	40		
STS 4x15	3.57	6	816	40.8	26.8	3	6	30	6680827	
STS 4x15	4	20	648	30.8	21.2	5.5	5.5	30		6681628
STS 5x25	3.96	20	384	35.0	26.2	8	6	30	6681372	6681372.78
STS 8x25	4.67	20	272	43.8	29.7	6.5	6.5	40	6680992	6680926
STS 10x40	4.5	30	116+58	43.0	32.2	10	9.5	40		
STS 11x25	4.48	30	232	45.2	34.9	7	8	30		6681639

Other apertures on request. SLS = With flow, STS = Cross flow

Trellex LS PU Dewatering 300LS-610

Hole type	Module weight (kg)	Thickness screen area (mm)	Quantity apertures per panel	Relative open area (%)	Effective open area (%)	Min web thickness with flow (mm)	Min web thickness cross flow (mm)	Build height (mm)	Part No. 75/90 (Sh-D/Sh-A)
SLS0.3x11.5	5.6	8	2592	7.7	4.9	2.9	2.6	40	MM0391754
SLS0.4x12.4	5.6	8	2592	11.6	7.0	2.7	1.4	40	MM0399118
SLS0.5x12.5	5.6	8	2448	13.7	8.4	2.8	1.3	40	MM0399129
SLS0.63x12	5.7	8	2304	15.4	9.5	2.9	1.9	40	MM0399134
SLS0.8x12	5.6	8	2304	18.7	12.1	2.7	1.9	40	MM0399142
SLS0.3x11.5 - HD*	6.6	8	2304	7.7	4.3	2.9	2.6	40	
SLS0.4x12.4 - HD*	6.6	8	2304	11.6	6.2	2.7	1.4	40	
SLS0.5x12.5 - HD*	6.6	8	2176	13.7	7.4	2.8	1.3	40	
SLS0.63x12 - HD*	6.7	8	2048	15.4	8.5	2.9	1.9	40	
SLS0.8x12 - HD*	6.6	8	2048	18.7	10.7	2.7	1.9	40	
STS0.3x11.5	5.8	8	2592	7.7	4.9	2.6	2.9	40	MM0399114
STS0.4x12.4	5.6	8	2592	11.6	7.0	1.4	2.7	40	MM0399123
STS0.5x12.5	5.6	8	2448	13.7	8.4	1.3	2.8	40	MM0399132
STS0.63x12	5.7	8	2304	15.4	9.5	1.9	2.9	40	MM0399137
STS0.8x12	5.6	8	2304	18.7	12.1	1.9	2.7	40	MM0399145
STS0.3x11.5 - HD*	6.6	8	2304	7.7	4.3	2.6	2.9	40	
STS0.4x12.4 - HD*	6.6	8	2304	11.6	6.2	1.4	2.7	40	
STS0.5x12.5 - HD*	6.6	8	2176	13.7	7.4	1.3	2.8	40	
STS0.63x12 - HD*	6.7	8	2048	15.4	8.5	1.9	2.9	40	
STS0.8x12 - HD*	6.6	8	2048	18.7	10.7	1.9	2.7	40	

* HD = Heavy Duty with ability to carry 200-300mm bed depth depending on slurry density

** Injection moulded openings cast into module

Trellex LS PU Standard

Trellex 305LS-610

Available molded slotted apertures (SLS/STS)

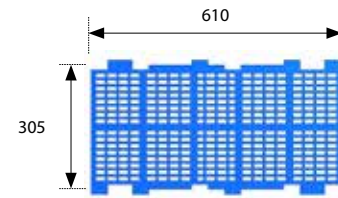

Hole type	Module weight (kg)	Thickness screen area (mm)	Quantity apertures per panel	Relative open area (%)	Effective open area (%)	Min web thickness with flow (mm)	Min web thickness cross flow (mm)	Build height (mm)	Part No. 75/90 (Sh-D/Sh-A)	Part No. 75/80 (Sh-D/Sh-A)
SLS 0.63x12	3.93	8	1914	13.0	7.6	4	3	30	6680638	
SLS 0.8x12	3.76	8	1682	12.5	8.7	5.5	3.3	30		6681635
SLS 1x13	3.52	6	1740	19.7	12.2	3.5	3	30	6680501	
SLS 1x17	4.21	15	1248	16.1	11.4	5	3.8	30	6681380.90	6681380
SLS 1.4x20	3.28	14	1392	26.9	21.5	3.1	3.1	30		MM0358111
SLS 1.5x12	3.62	7	1392	20.6	13.5	5.5	3.5	30	6680502	
SLS 1.6x19	3.51	15	1248	26.1	20.7	3.45	4.1	30		MM0358114
SLS 1.6x20	2.77	8	1392	31.0	24.5	2.9	2.9	30	MM0358117	
SLS 2x12	3.79	8	1218	24.9	15.7	5.5	3.5	30	6680503	6680503.78
SLS 2.5x12	3.82	10	1044	26.4	16.8	5.5	4	30		6681484
SLS 3x22	3.72	20	720	33.7	25.5	4	6	30		MM0353017
SLS 4x15	3.9	12	720	34.1	23.2	7	4	30	6680848	6680848.78
SLS 4x22	3.5	16	640	39.3	29.7	4	6	30		6681624
SLS 5x15	3.93	12	624	37.9	25.1	7	4	30		6681634
SLS 5x26	4.22	20	360	30.8	24.7	13.5	5.7	30		6681379
SLS 6x20HD	4.29	20	380	35.7	24.5	8	6	30		6680723.78. BLUE
SLS 7x32	3.5	20	300	45.3	35.2	6	6	30		6681414.78
SLS 8x27.5	4.99	30	240	35.9	27.5	8.3	10	40		MM0378899
SLS 8x56	3.9	20	144	41.0	34.7	6.4	19.5	30		6681623
SLS 9x13	3.49	12	522	47.6	32.8	4.8	4.8	30	6680993	6680993.78
SLS 10x22	3.7	20	320	45.3	35.2	6	6	30	6681451	6681451.78
SLS 12x25	3.74	20	180	34.9	29.0	10	14	30		6681151.78
SLS 12x50	3.46	20	108	41.3	34.8	16	10	30		6681153.78
SLS 12x27.5	4.95	30	180	39.0	30.9	10	10	40		MM0367346
SLS 14x25	3.18	15	180	41.4	33.8	14	7.7	30		6681292
SLS 16.7x25	4.4	30	160	46.4	35.9	10	9	40		6680846
SLS 19x51.5	4.18	30	81	56.8	42.6	9	10	40		MM0358125
SLS 25x48	4.31	30	81	47.3	40.6	17	14	40		6680929
SLS 26x32	4.65	30	84	47.2	38.2	10	17	40	6681194.90	6681194.78
SLS 30x58	4.33	30	48	53.0	44.9	15	15	40		6680930
SLS 37x57	4.39	40	40	51.6	45.3	17.5	18	40		MM0372738
SLS 37x112	6.49	40	40	39.2	35.6	35.7	33.5	40		MM0372739
STS 0.63x12	3.3	8	2016	11.8	8.2	3.5	3.5	30	6681087	
STS 0.8x12	4.32	8	1764	14.0	9.1	3	6	30	6680853	

Table continues on next page

Hole type	Module weight (kg)	Thickness screen area (mm)	Quantity apertures per panel	Relative open area (%)	Effective open area (%)	Min web thickness with flow (mm)	Min web thickness cross flow (mm)	Build height (mm)	Part No. 75/90 (Sh-D/Sh-A)	Part No. 75/80 (Sh-D/Sh-A)
STS 1x12HD	4.73	10	1148	11.8	7.4	5	5	40	6680852	
STS 1.5x12	3.7	7	1498	23.5	14.5	3	5	30	6680851	
STS 2x12	3.56	8	1036	18.5	13.4	5	7	30	6681573	
STS 2.5x12	4.44	20	896	46.9	14.4	5.5	5.5	30		6681025.78
STS 2.5x25HD	5.61	30	315	14.2	10.5	10	10	40		MM0358106
STS 3x12HD	4.47	20	826	24.2	16.0	5.5	8	30	6680850	
STS 3x20	4.63	15	640	28.8	18.5	8	5	40	MM0384455	
STS 4x15	3.68	6	816	40.8	26.3	3	6	30	6680849	
STS 4x15	4.11	20	648	30.8	20.9	5.5	5.5	30		6681633
STS 5x25	4.07	20	384	35.0	25.8	8	6	30	6681195.90	6681195.78
STS 8x25	4.82	20	272	43.8	29.2	6.5	6.5	40		6681083
STS 10x40	4.64	30	116+58	43.0	32.2	10	9.5	40		MM0384454
STS 11x25	4.59	30	232	45.2	34.3	7	8	30		6681646

Other apertures on request.
SLS = With flow, STS = Cross flow

Trellex LS PU Standard

Trellex 610LS-305

Available slotted apertures (SLS)

Hole type	Module weight (kg)	Thickness screen area (mm)	Quantity apertures per panel	Relative open area (%)	Effective open area (%)	Min web thickness with flow (mm)	Min web thickness cross flow (mm)	Build height (mm)	Part No. 75/90 (Sh-D/Sh-A)	Part No. 75/80 (Sh-D/Sh-A)
SLS 0.3x12		4.75/8	2894	8.0	5.6	2.5	4	40	ZX11334761	
SLS 0.5x13		6/7	2430	16.3	8.5	2	3	40	9260010400004	
STS 0.5x13		9/20	2430	16.3	6.9	2	3	40	ZX11151829	ZX11303861
SLS 0.75x13		9/20	2423	16.3	11.4	3	3	40	9260010400005	
SLS 1.0x13		9/20	2432	24.6	17.0	2.3	3	40	9260010400006	
SLS 1.25x13		9/20	2427	31.2	20.1	2	3	40	9260010400045	
SLS 1.4x13		9/20	950	30.7	21.3	2.3	3	40	9260010400001	
SLS 1.8x13		9/20						40	9260010400011	

Trellex LS PU Standard

Trellex 300/305LS-500/610

Blind LS polyurethane modules

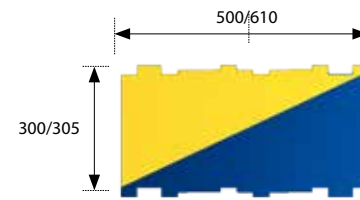

For impact zones or heavy wear points

Module Size (mm)	Thickness membrane (mm)	Build height (mm)	Top PU layer thickness (mm)	Module weight (kg)	Part No. 75/90 (Sh-D/Sh-A)	Part No. 75/80 (Sh-D/Sh-A)
300x500	20	30	10	4.6	MM0364099	MM0360256
300x610	20	30	10	5.7	6681611	MM0360257
305x610	20	30	10	5.8	MM0349977	6681610
300x500	30	40	20	6.5	MM0358484	MM0360258
300x610	30	40	20	7.9	Non Standard	MM0358483
305x610	30	40	20	8		MM0347609

Trellex LS RU Standard

Trellex 300LS-610

Rubber 40° Shore A– blind modules for punching

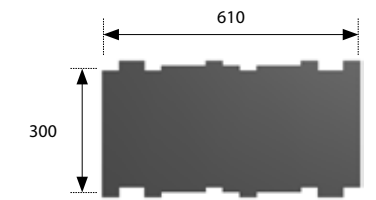

Part No.	Item	Description	Module weight (kg)	Wear thickness (mm)	Build height (mm)
6670251	300LS-610 RU	300LS-610-30-2.5-T40-UNP	4.3	2.5	30
6670153	300LS-610 RU	300LS-610-30-3.5-T40-UNP	4.4	3.5	30
6670149	300LS-610 RU	300LS-610-30-5.5-T40-UNP	4.6	5.5	30
6670152	300LS-610 RU	300LS-610-30-8-T40-UNP	4.9	8	30
6670256	300LS-610 RU	300LS-610-30-11-T40-UNP	5.3	11	30

Punching dies are available for more or less any square aperture (FR) between 2 to 200 mm. For rectangular apertures, slot widths are available in 1.5-100 mm. Slot lengths are normally 1 to 4 times the slot width.

Trellex LS RU Standard

Trellex 300LS-500

Rubber 40° Shore A– blind modules for punching

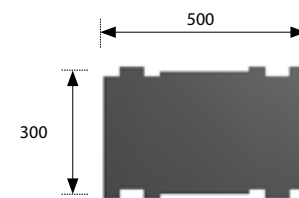

Part No.	Item	Description	Module weight (kg)	Wear thickness (mm)	Build height (mm)
6670213	300LS-500 RU	300LS-500-30-2.5-T40-UNP	3.4	2.5	30
6670154	300LS-500 RU	300LS-500-30-3.5-T40-UNP	3.7	3.5	30
6670151	300LS-500 RU	300LS-500-30-5.5-T40-UNP	3.9	5.5	30
6670150	300LS-500 RU	300LS-500-30-8-T40-UNP	4.2	8	30
6670218	300LS-500 RU	300LS-500-30-11-T40-UNP	4.6	11	30

Punching dies are available for more or less any square aperture (FR) between 2 to 200 mm. For rectangular apertures, slot widths are available in 1.5-100 mm. Slot lengths are normally 1 to 4 times the slot width.

Trellex LS RU Standard

Trellex 300LS-500

Rubber 60° Shore A – blind modules

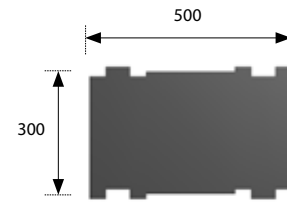

For punching

Part No.	Item	Description	Module weight (kg)	Wear thickness (mm)	Manufacturing country	Build height (mm)
6670214	300LS-500 RU	300LS 500-30-2.5-SF/T60-UNP	3.8	2.5	SE, BR	30
6670215	300LS-500 RU	300LS 500-30-3.5-SF/T60-UNP	4	3.5	SE, BR	30
6670216	300LS-500 RU	300LS 500-30-5.5-SF/T60-UNP	4.2	5.5	SE, BR	30
6670217	300LS-500 RU	300LS 500-30-8-SF/T60-UNP	4.5	8	SE, BR	30
6670148	300LS-500 RU	300LS-500-30-11-T60-UNP	4.9	11	SE, BR	30
6670219	300LS-500 RU	300LS-500-40-15-T60-UNP	5.8	15	SE, BR	40
6670146	300LS-500 RU	300LS-500-40-20-T60-UNP	6.4	20	SE, BR	40
6670220	300LS-500 RU	300LS-500-40-25-T60-UNP	7.0	25	SE, BR	40
6670210	300LS-500 RU	300LS-500-60-35-T60-UNP	10.3	35	SE, BR	60
6670209	300LS-500 RU	300LS-500-60-45-T60-UNP	11.5	45	SE, BR	60

For impact zones or heavy wear points

Part No.*	Item	Description	Module weight (kg)	Wear thickness (mm)	Manufacturing country	Build height (mm)
MM0360969	300LS-500 RU	300LS 500-30-20-SF/T60-UNPHDM	4.9	20	SE, BR	30
MM0360970	300LS-500 RU	300LS 500-40-20-SF/T60-UNPHDM	5.3	20	SE, BR	40
MM0360971	300LS-500 RU	300LS 500-40-30-SF/T60-UNPHDM	6.6	30	SE, BR	40
MM0419949	300LS-500 RU	300LS 500-60-40-SF/T60-UNPHDM	8.8	40	SE, BR	60

* Specially adapted internal reinforcement to carry high loads.

Punching dies are available for more or less any square aperture (FR) between 2 to 200 mm.

For rectangular apertures, slot widths are available in 1.5-100 mm. Slot lengths are normally 1 to 4 times the slot width.

Trellex LS RU Standard

Trellex 300LS-610

Rubber 60° Shore A – blind modules for punching

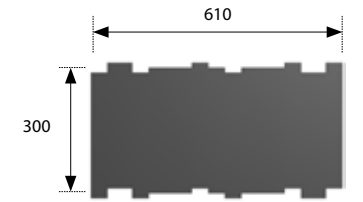

For punching

Part No.	Item	Description	Module weight (kg)	Wear thickness (mm)	Manufacturing country	Build height (mm)
6670252	300LS-610 RU	300LS 610-30-2.5-SF/T60-UNP	4.5	2.5	SE, BR	30
6670253	300LS-610 RU	300LS 610-30-3.5-SF/T60-UNP	4.4	3.5	SE, BR	30
6670254	300LS-610 RU	300LS 610-30-5.5-SF/T60-UNP	5	5.5	SE, BR	30
6670255	300LS-610 RU	300LS 610-30-8-SF/T60-UNP	5.3	8	SE, BR	30
6670147	300LS-610 RU	300LS-610-30-11-T60-UNP	6.2	11	SE, BR	30
6670257	300LS-610 RU	300LS-610-40-15-T60-UNP	6.7	15	SE, BR	40
6670145	300LS-610 RU	300LS-610-40-20-T60-UNP	7.5	20	SE, BR	40
6670155	300LS-610 RU	300LS-610-40-25-T60-UNP	8.3	25	SE, BR	40
6670258	300LS-610 RU	300LS-610-60-35-T60-UNP	12.2	35	SE, BR	60
6670162	300LS-610 RU	300LS-610-60-45-T60-UNP	13.7	45	SE, BR	60

For impact zones or heavy wear points

Part No.* (T60)	Item	Description	Module weight (kg)	Thickness membrane (mm)	Manufacturing country	Build height (mm)
MM0360965	300LS-610 RU	300LS 610-30-20-SF/T60-UNPHDM	6	20	SE, BR	30
MM0360966	300LS-610 RU	300LS 610-40-20-SF/T60-UNPHDM	6.5	20	SE, BR	40
MM0360972	300LS-610 RU	300LS 610-40-30-SF/T60-UNPHDM	8	30	SE, BR	40
MM0413745	300LS-610 RU	300LS 610-60-40-SF/T60-UNPHDM	12.5	40	SE, BR	60

* Specially adapted internal reinforcement to carry high loads.

Punching dies are available for more or less any square aperture (FR) between 2 to 200 mm.

For rectangular apertures, slot widths are available in 1.5-100 mm. Slot lengths are normally 1 to 4 times the slot width.

Trellex LS RU Standard

Trellex 300LS-500

Rubber 60° Shore A, injection molded apertures (FR)

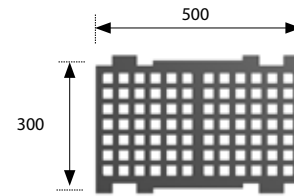

Hole type	Module weight (kg)	Thickness screen area (mm)	Quantity apertures per panel	Relative open area (%)	Effective open area (%)	Min web thickness with flow (mm)	Min web thickness cross flow (mm)	Build height (mm)	Design*	Manufacturing country	Part No.
FR3.2	2.5	4	2880	27.5%	19.7%	2.8	3	30	LD	SE	6670601
FR4.0	2.5	4	2040	30.4%	21.8%	3.2	3.3	30	LD	SE	6670603
FR4.8	2.5	4	1479	31.5%	22.7%	3.7	3.8	30	LD	SE	6670605
FR4.8-MKII	2.8	5	1508	32.3%	23.2%	3.8	3.5	30	STD	SE	MM0421433
FR4.8-MKII	3.2	5	1508	32.3%	23.2%	3.8	3.5	40	STD	SE	MM0421454
FR5.4	2.5	5	1296	34.8%	25.2%	3.6	3.9	30	LD	SE, BR	6670607
FR5.4-MKII	2.8	5	1296	35.2%	25.2%	3.9	3.5	30	STD	SE	MM0421465
FR5.4-MKII	3.2	5	1296	35.2%	25.2%	3.9	3.5	40	STD	SE	MM0421471
FR6.5	2.5	5	1008	42.3%	28.4%	3.5	3.5	30	LD	SE, BR	6670609
FR8.5	2.4	6	720	47.0%	34.6%	3.7	4	30	LD	SE, BR	6681014
FR10	3.2	12	448	41.6%	29.9%	5.7	5.3	30	STD	SE, BR	MM0371188
FR10	3.6	12	448	41.6%	29.9%	5.7	5.3	40	STD	SE, BR	MM0371191
FR12	2.7	12	336	43.0%	32.3%	6.6	6	30	LD	SE	6670694
FR12-MKII	3.1	12	336	44.4%	32.3%	6	6	30	STD	BR	MM0375169
FR12-MKII	3.5	12	336	44.4%	32.3%	6	6	40	STD	BR	MM0375171
FR13	3.1	12	312	45.8%	32.4%	6.4	6	30	STD	SE	ZX11156079
FR13	3.5	12	312	45.8%	32.4%	6.4	6	40	STD	SE	MM0345256
FR14	3.6	20	240	43.2%	31.4%	7	7.6	30	STD	SE	MM0344814
FR14	4	20	240	43.2%	31.4%	7	7.6	40	STD	SE	MM0344816
FR16	3.5	20	220	50.0%	35.7%	6.3	6.9	30	STD	SE, BR	MM0353391
FR16	3.9	20	220	50.0%	35.7%	6.3	6.9	40	STD	SE, BR	MM0353397
FR18	3.6	20	160	45.7%	34.6%	10	7.3	30	STD	SE, BR	MM0353610
FR18	4	20	160	45.7%	34.6%	10	7.3	40	STD	SE, BR	MM0351294
FR20-MK2	3.8	20	144	52.9%	38.4%	8	7	40	STD	SE	MM0424545
FR20	3.2	20	144	49.8%	38.4%	8.7	8	40	LD	SE, BR	6670700
FR22	3.5	20	128	50.7%	36.1%	9.85	8	30	STD	SE, BR	MM0359320
FR22	3.9	20	128	50.7%	36.1%	9.85	8	40	STD	SE, BR	MM0359322
FR25	3.6	25	84	44.2%	35.0%	14	11.3	40	LD	SE	6670691
FR25HD	4.4	30	84	46.4%	35.0%	11.4	12	40	HD	SE, BR	MM0361820
FR30	3.6	25	60	44.5%	36.0%	17.5	12.6	40	LD	SE, BR	6670725
FR32	3.5	25	50+10	47.9%	37.5%	15	13.5	40	LD	SE, BR	6670728
FR35	4.1	30	45	45.9%	36.8%	17	16.3	40	LD	SE, BR	6670731
FR38	3.7	30	40	46.5%	38.5%	22.6	13.2	40	LD	SE	6681015
FR38HD	4.5	35	40	47.0%	38.5%	13.2	22	40	HD	SE, BR	MM0375175
FR40	3.7	30	16+8	47.8%	38.4%	20	15.75	40	LD	SE	6670652
FR50	3.8	30	24	48.2%	40.0%	30.6	14.4	40	LD	SE	6670729
FR60	4.8	35	15	40.5%	36.0%	30.5	38.2	40	STD	SE	MM0415073
FR60	6.5	35	15	40.5%	36.0%	30.5	38.2	60	HD	SE	MM0415074

Other apertures on request.

SLS = With flow,
STS = Cross flow

Can be manufactured with soft flex rubber 40° shore hardness upon request, see Trellex LS HiPer Clean. Always check with Metso representative if suitable.

LD = Light Duty
STD = Standard Duty
HD = Heavy Duty
XHD = Extra Heavy Duty

Trellex LS RU Standard

Trellex 300LS-500

Rubber 60° Shore A, injection molded apertures (SLS)

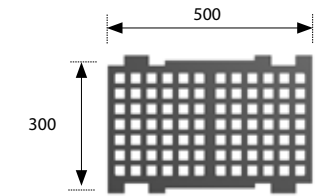

Hole type	Module weight (kg)	Thickness screen area (mm)	Quantity apertures per panel	Relative open area (%)	Effective open area (%)	Min web thickness with flow (mm)	Min web thickness cross flow (mm)	Build height (mm)	Design*	Manufacturing country	Part No.
SLS3x12.5	2.7	8	960	33.4%	24.0%	3.3	5.3	30	STD	SE	MM0409024
SLS3x12.5	3.1	8	960	33.4%	24.0%	3.3	5.3	40	STD	SE	MM0409023
SLS8x28.5	3.6	20	204	41.9%	31.0%	6.9	8	30	STD	SE, BR	MM0353488
SLS8x28.5	4.1	20	204	41.9%	31.0%	6.9	8	40	STD	SE, BR	MM0353506
SLS10x25-MKII	3.7	20	168	36.3%	28.0%	8.1	13	40	STD	BR	MM0393627
SLS10x25-MKII	4.1	20	168	36.3%	28.8%	8.1	13	40	STD	BR	MM0393625
SLS12.5x27.5	3.9	25	144	44.6%	33.0%	8.6	9	30	STD	SE, BR	MM0353409
SLS12.5x27.5	4.3	25	144	44.6%	33.0%	8.6	9	40	STD	SE, BR	MM0353394
SLS16x44	3.6	25	80	49.6%	37.5%	9.35	12	30	STD	SE	MM0372072
SLS16x44	4	25	80	49.6%	37.5%	9.35	12	40	STD	SE	MM0372073
SLS20x40	4.5	30	64	42.5%	34.1%	11.9	19	40	STD	SE	MM0344806
SLS45x95	6.8	50	16	53.5%	45.6%	20	27.8	60	STD	SE	MM0364863
SLS50x95	6.9	50	12+4	54.1%	44.3%	21.5	27.8	60	STD	BR	MM0372275

Other apertures on request.

SLS = With flow,
STS = Cross flow

Can be manufactured with soft flex rubber 40° shore hardness upon request, see Trellex LS HiPer Clean. Always check with Metso representative if suitable.

* LD = Light Duty
STD = Standard Duty
HD = Heavy Duty
XHD = Extra Heavy Duty

Trellex LS RU Standard

Trellex 300LS-610

Rubber 60° Shore A, injection molded apertures (FR)

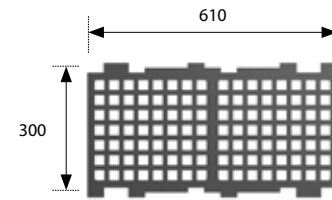

Hole type	Module weight (kg)	Thickness screen area (mm)	Quantity apertures per panel	Relative open area (%)	Effective open area (%)	Min web thickness with flow (mm)	Min web thickness cross flow (mm)	Build height (mm)	Design*	Manufacturing country	Part No.
FR3.2	2.9	4	3360	26.3%	18.8%	3	2.8	30	LD	SE	6670623
FR4.8	2.9	4	1740	31.5%	21.9%	3.8	3.7	30	LD	SE	6670638
FR4.8-MKII	3.4	5	1798	32.3%	22.6%	3.8	3.5	30	STD	SE	MM0421435
FR4.8-MKII	3.9	5	1798	32.3%	22.6%	3.8	3.5	40	HD	SE	MM0421456
FR5.4	3	5	1512	34.8%	24.1%	3.9	3.6	30	LD	SE, BR	6641575
FR5.4-MKII	3.4	5	1566	35.2%	25.0%	3.9	3.5	30	STD	SE	MM0421467
FR5.4-MKII	3.9	5	1566	35.2%	25.0%	3.9	3.5	40	HD	SE	MM0421473
FR6.5	2.9	5	1248	39.8%	28.8%	4	3.6	30	LD	SE, BR	6670627
FR8.5	2.9	6	880	47.8%	34.7%	4	3.6	30	LD	SE, BR	6681016
FR10	3.8	12	544	41.6%	29.7%	5.7	5.3	30	STD	SE, BR	MM0371179
FR10	4.3	12	544	41.6%	29.7%	5.7	5.3	40	STD	SE, BR	MM0371184
FR12	3.4	12	392	41.0%	30.8%	6	7.5	30	LD	SE	6670696
FR12-MKII	3.8	12	406	44.4%	31.9%	6	6	30	STD	BR	MM0375164
FR12-MKII	4.3	12	406	44.4%	31.9%	6	6	40	STD	BR	MM0375167
FR13	3.8	12	377	45.8%	32.0%	6.4	6	30	STD	SE	ZX11156080
FR13	4.2	12	377	45.8%	32.0%	6.4	6	40	STD	SE	MM0345258
FR14	4.3	20	288	43.2%	30.8%	7	7.6	30	STD	SE	MM0344811
FR14	4.8	20	288	43.2%	30.8%	7	7.6	40	STD	SE	MM0344809
FR16	4.3	20	264	50.0%	35.4%	6.9	6.3	30	STD	SE, BR	MM0353393
FR16	4.8	20	264	50.0%	35.4%	6.9	6.3	40	STD	SE, BR	MM0353402
FR18	4.4	20	200	45.7%	34.1%	10	7.3	30	STD	SE, BR	MM0353679
FR18	4.9	20	200	45.7%	34.1%	10	7.3	40	STD	SE, BR	MM0353678
FR20	3.8	20	180	50.3%	39.3%	8	8.4	40	LD	SE, BR	6670701
FR20-MK2	4.6	20	162+18	52.9%	38.2%	8	7	40	STD	SE	MM0424536
FR22	4.2	20	152	50.7%	36.0%	9.85	8	30	STD	SE, BR	MM0359316
FR22	4.7	20	152	50.7%	36.0%	9.85	8	40	STD	SE, BR	MM0359318
FR25	4.1	25	112	48.4%	38.3%	11.3	10.6	40	LD	SE	6670692
FR25SHD	5.4	30	98+7	46.4%	34.7%	11.4	12	40	HD	SE, BR	MM0360897
FR28	4.4	25	84	47.6%	36.0%	15	10.3	40	LD	SE	ZX11161412
FR30	4.3	25	72	43.1%	35.4%	12.6	19	40	LD	SE, BR	6670726
FR32	4.2	25	60+12	43.4%	36.9%	13.5	16.6	40	LD	SE, BR	6670712
FR35	4.3	30	60	49.1%	40.2%	17	13	40	LD	SE, BR	6670713
FR38	4.4	30	50	47.7%	39.5%	13.2	21.2	40	LD	SE	6681009
FR38HD	5.7	35	40+10	47.0%	38.2%	13.2	22	40	HD	SE, BR	MM0375174
FR40	4.4	30	40+10	48.9%	39.3%	15.8	18.7	40	LD	SE	6670654
FR45	5.5	35	36	48.0%	39.8%	20.5	19	40	STD	SE, BR	MM0361689
FR50	4.2	30	32	51.8%	43.7%	14.4	25	40	LD	SE	6670714
FR55	7.1	45	24+8	56.0%	45.7%	18.5	18.5	60	HD	SE	MM0359323
FR60	5.9	35	18	40.0%	35.4%	30	40	40	STD	SE	MM0415071
FR60	7.9	35	18	40.0%	35.4%	30	40	60	HD	SE	MM0415072
FR64	7.4	35	18	48.6%	40.3%	22	34	60	LD	SE	6670715

Other apertures on request.

Can be manufactured with soft flex rubber 40° shore hardness upon request, see Trellex LS HiPer Clean. Always check with Metso representative if suitable.

* LD = Light Duty
STD = Standard Duty
HD = Heavy Duty
XHD = Extra Heavy Duty

Trellex LS RU Standard

Trellex 300LS-610

Rubber 60° Shore A, injection molded apertures (SLS)

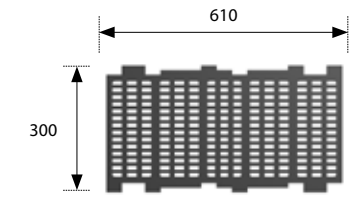

Hole type	Module weight (kg)	Thickness screen area (mm)	Quantity apertures per panel	Relative open area (%)	Effective open area (%)	Min web thickness with flow (mm)	Min web thickness cross flow (mm)	Build height (mm)	Design*	Manufacturing country	Part No.
SLS3x12.5	3.3	8	1160	33.4%	23.3%	3.3	5.3	30	STD	SE	MM0406277
SLS3x12.5	3.7	8	1160	33.4%	23.3%	3.3	5.3	40	STD	SE	MM0406278
SLS5x17.5	4	10	624	40.5%	29.8%	4.7	4.9	40	STD	SE	MM0345238
SLS8x28.5	4.4	20	254	41.9%	30.7%	6.9	8	30	STD	SE, BR	MM0353509
SLS8x28.5	4.9	20	254	41.9%	30.7%	6.9	8	40	STD	SE, BR	MM0353515
SLS9.5x32M	8.2	45	168	37.9%	27.9%	8.5	12.6	60	XHD	SE	MM0366248
SLS10x25M-MKII		20	210	36.3%	27.2%	8.1	13	30	STD	BR	MM0393630
SLS10x25M-MKII	5	20	210	36.3%	27.2%	8.1	13	40	STD	BR	MM0393631
SLS10x25	5.2	25	224	40.0%	30.6%	8.1	9.5	40	STD	SE	MM0345245
SLS12.5x27.5	4.7	25	180	44.6%	32.7%	8.6	9	30	STD	SE, BR	MM0353398
SLS12.5x27.5	5.2	25	180	44.6%	32.7%	8.6	9	40	STD	SE, BR	MM0353403
SLS12.5x27.5SHD	10.7	45	143	39.0%	26.9%	10	12	60	XHD	SE	MM0357288
SLS12.5x36	3.9	20	144	44.5%	35.4%	8.6	12	40	LD	SE	6681017
SLS14x56	5.2	25	80	43.3%	34.3%	11.5	15	40	STD	SE	MM0363501
SLS16x44	4.4	25	100	49.6%	31.2%	9.35	12	30	STD	SE, BR	MM0372074
SLS16x44	4.9	25	100	49.6%	31.2%	9.35	12	40	STD	SE, BR	MM0372075
SLS20x40	5.4	30	80	42.5%	34.1%	11.9	16	40	STD	SE	MM0344807
SLS25x57	5.6	35	56	53.4%	43.6%	11.8	15	40	STD	SE, BR	MM0347591
SLS25x78	5.7	35	36	44.3%	38.4%	19	22	40	HD	SE	MM0350999
SLS25x54	7.8	45	48	43.2%	35.4%	18.5	18	60	XHD	SE, BR	MM0368117
SLS32x70	5.7	35	30	41.8%	36.7%	20	33	40	STD	SE, BR	MM0353286
SLS35x105	10.2	45	16	37.1%	32.1%	31	45	60	HD	SE	MM0357293
SLS40x70	5.8	35	24	42.4%	36.7%	26	30	40	STD	BR	MM0375177
SLS45x75	6.6	45	24	51.4%	44.3%	20.6	25.1	60	XHD	SE	MM0361826
SLS45x95	8.3	50	20	53.5%	45.6%	20	27.8	60	HD	SE	MM0364907
SLS50x95	8.4	50	15+5	54.1%	44.1%	21.5	27.8	60	HD	BR	MM0372273
SLS60x110	9.6	45	12	52.1%	43.3%	24.5	40	60	HD	SE	MM0372859
SLS90/60x110M	9.7	55/45	6+3	52.1%	43.3%	24.5	40	60	XHD	SE	MM0380357
SLS90x110	9.7	55	8	52.1%	43.3%	50	40	60	XHD	SE	MM0401816

Other apertures on request.
SLS = With flow, STS = Cross flow

Can be manufactured with soft flex rubber 40° shore hardness upon request, see Trellex LS HiPer Clean. Always check with Metso representative if suitable.

* LD = Light Duty
STD = Standard Duty
HD = Heavy Duty
XHD = Extra Heavy Duty

Trellex LS RU Standard

Trellex 305LS-610

Rubber 60° Shore A, injection molded apertures (FR)

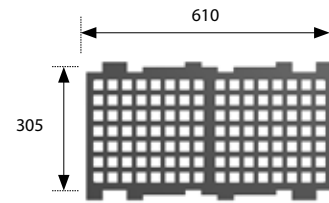

Hole type	Module weight (kg)	Thickness screen area (mm)	Quantity apertures per panel	Relative open area (%)	Effective open area (%)	Min web thickness with flow (mm)	Min web thickness cross flow (mm)	Build height (mm)	Design*	Manufacturing country	Part No.
FR3.2	2.9	4	3360	26.3%	18.5%	3	2.8	30	LD	SE	6670625
FR4.8	3	4	1740	31.5%	21.5%	3.8	3.7	30	LD	SE	6670631
FR4.8-MKII	3.5	5	1798	32.3%	22.3%	3.8	3.5	30	STD	SE	MM0421437
FR4.8-MKII	4	5	1798	32.3%	22.3%	3.8	3.5	40	HD	SE	MM0421461
FR5.4	3.1	5	1512	34.8%	23.7%	3.9	3.6	30	LD	SE, BR	6670722
FR5.4-MKII	3.6	5	1566	35.2%	24.5%	3.9	3.5	30	STD	SE	MM0421469
FR5.4-MKII	4.1	5	1566	35.2%	24.5%	3.9	3.5	40	HD	SE	MM0421476
FR6.5	3	5	1248	39.8%	28.3%	4	3.6	30	LD	SE, BR	6670629
FR8.5	3	6	880	47.8%	20.0%	4	3.6	30	LD	SE, BR	6681011
FR10	4	12	544	41.6%	29.2%	5.7	5.3	30	STD	IN, SE, BR	MM0371182
FR10	4.6	12	544	41.6%	29.2%	5.7	5.3	40	STD	IN, SE, BR	MM0371186
FR12-MKII	4	12	406	44.4%	31.4%	6	6	30	STD	IN, US, BR	MM0369436
FR12-MKII	4.5	12	406	44.4%	31.4%	6	6	40	STD	IN, US, BR	MM0369438
FR12	3.4	12	392	41.0%	30.3%	6	7.5	30	STD	SE	6670698
FR13	4	12	377	45.8%	31.5%	6.4	6	30	STD	SE	ZX11156081
FR13	4.4	12	377	45.8%	31.5%	6.4	6	40	STD	SE	MM0345259
FR14	4.4	20	288	43.2%	30.3%	7	7.6	30	STD	SE	MM0345246
FR14	4.9	20	288	43.2%	30.3%	7	7.6	40	STD	SE	MM0345248
FR16	4.5	20	264	50.0%	34.8%	6.9	6.3	30	STD	SE, IN, BR	MM0353291
FR16	5	20	264	50.0%	34.8%	6.9	6.3	40	STD	SE, IN, BR	MM0351962
FR18	4.6	20	200	45.7%	33.6%	10	7.3	30	STD	SE, US, BR	MM0353668
FR18	5.1	20	200	45.7%	33.6%	10	7.3	40	STD	SE, US, BR	MM0353667
FR20	3.9	20	180	50.3%	38.7%	8	8.4	40	LD	SE, BR	6670716
FR20-MK2	4.8	20	162+18	52.9%	37.5%	8	7	40	STD	SE	MM0424539
FR22	4.4	20	152	50.7%	35.4%	9.85	8	30	STD	SE, BR	MM0359317
FR22	4.9	20	152	50.7%	35.4%	9.85	8	40	STD	SE, BR	MM0359319
FR25	4.2	25	112	48.4%	37.6%	11.3	10.6	40	LD	SE	6670690
FR25HD	5.6	30	98+7	46.4%	34.1%	11.4	12	40	HD	SE, US, BR	MM0360875
FR28	4.5	25	84	47.6%	35.4%	15	10.3	40	LD	SE	6670873
FR30	4.4	25	72	43.1%	34.8%	12.6	19	40	LD	SE, BR	6670727
FR32	4.3	25	60+12	43.4%	36.9%	13.5	16.6	40	LD	SE, BR	6670717
FR32-MKII	5.3	30	60+12	47.6%	36.9%	13.5	15.3	40	HD	US	MM0408249
FR35	4.4	30	60	49.1%	39.5%	17	13	40	LD	SE, BR	6670723
FR38	4.5	30	50	47.7%	38.8%	13.2	21.2	40	LD	SE	6681012
FR38HD	5.8	35	40+10	47.0%	37.6%	13.2	22	40	HD	SE, BR	MM0366263
FR40	4.5	30	40+10	48.9%	39.3%	15.8	18.7	40	LD	SE	6680955
FR40HD	5.8	35	40+10	49.2%	38.0%	15.6	18.5	40	HD	IN, US	MM0369450
FR45	5.7	35	36	48.0%	39.2%	20.5	19	40	STD	SE, BR	MM0360388
FR50	4.3	30	32	51.8%	43.0%	14.4	25	40	LD	SE, US	6670718
FR55	7.3	45	24+8	56.0%	44.9%	18.5	18.5	60	HD	SE	MM0359324
FR60	6	35	18	40.0%	34.8%	30	40	40	STD	SE	MM0411883
FR60	8.1	35	18	40.0%	34.8%	30	40	60	HD	SE	MM0415016
FR64	7.6	35	18	48.6%	39.6%	22	34	60	LD	SE	6670719
FR64-MKII	8.4	50	18	46.5%	39.6%	24	36	60	HD	US	MM0408247
FR76	7.8	50	12+6	56.3%	45.6%	26.5	24	60	HD	US	MM0408248

Other apertures on request.

Can be manufactured with soft flex rubber 40° shore hardness upon request, see Trellex LS HiPer Clean. Always check with Metso representative if suitable.

* LD = Light Duty
STD = Standard Duty
HD = Heavy Duty
XHD = Extra Heavy Duty

Trellex LS RU Standard

Trellex 305LS-610

Rubber 60° Shore A, injection molded apertures (SLS)

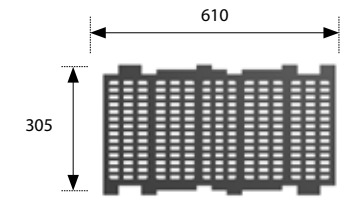

Hole type	Module weight (kg)	Thickness screen area (mm)	Quantity apertures per panel	Relative open area (%)	Effective open area (%)	Min web thickness with flow (mm)	Min web thickness cross flow (mm)	Build height (mm)	Design*	Manufacturing country	Part No.
SLS3x12.5	3.5	8	1160	33.4%	22.9%	3.3	5.3	30	STD	SE	MM0407801
SLS3x12.5	3.9	8	1160	33.4%	22.9%	3.3	5.3	40	STD	SE	MM0407805
SLS5x17.5	4.2	10	624	40.5%	29.3%	4.7	4.9	40	STD	IN, SE	ZX11155524
SLS8x28.5	4.6	20	254	41.9%	30.2%	6.9	8	30	STD	IN, BR, US, SE	MM0353670
SLS8x28.5	5.2	20	254	41.9%	30.2%	6.9	8	40	STD	IN, BR, US, SE	MM0353671
SLS9.5x32	8.4	45	168	37.9%	27.5%	8.4	11.6	60	XHD	SE, US	MM0366249
SLS10x25M-MKII	4.7	20	210	36.3%	27.2%	8.1	13	30	STD	IN, BR, US	MM0369446
SLS10x25M-MKII	5.1	20	210	36.3%	27.2%	8.1	13	40	STD	IN, BR, US	MM0369448
SLS10x25	5.3	25	224	40.0%	30.1%	8.1	9.5	40	STD	SE	6670890
SLS12.5x27.5	4.9	25	180	44.6%	32.1%	8.6	9	30	STD	IN, BR, US, SE	MM0353293
SLS12.5x27.5	5.5	25	180	44.6%	32.1%	8.6	9	40	STD	IN, BR, US, SE	MM0353289
SLS12.5x27.5HD	11	45	143	39.0%	26.2%	10	12	60	XHD	US, SE	MM0357296
SLS12.5x36	4	20	144	44.4%	34.8%	8.6	12	40	LD	SE	6681013
SLS14x56	5.4	25	80	43.3%	33.7%	11.5	15	40	STD	SE	MM0363495
SLS16x44	4.6	25	100	49.6%	30.7%	9.35	12	30	STD	IN, BR, SE	MM0369442
SLS16x44	5.1	25	100	49.6%	30.7%	9.35	12	40	STD	IN, BR, SE	MM0369444
SLS20x40	5.7	30	80	42.5%	33.5%	11.9	16	40	STD	IN, US, SE	MM0344808
SLS20x50	9.2	45	56	36.5%	30.1%	17	24	60	XHD	IN	MM0382887
SLS25x57	5.8	35	56	53.4%	42.9%	11.8	15	40	STD	BR, US, SE	MM0347592
SLS25x78	5.9	35	36	44.3%	37.7%	19	22	40	HD	SE	MM0350991
SLS25x54	8.8	45	48	43.2%	34.9%	18.5	18	60	XHD	BR, SE	MM0367343
SLS30x65	9.3	55	30	37.5%	31.4%	22	35	60	XHD	IN	MM0419676
SLS32x70	6.0	35	30	41.8%	36.1%	20	33	40	STD	BR, SE	MM0353287
SLS35x105	10.5	45	16	37.1%	31.6%	31	45	60	HD	SE	MM0357295
SLS36x65	9.3	55	24	35.7%	30.2%	29.5	35	60	XHD	IN, US	MM0369449
SLS40x70	5.8	35	24	42.4%	36.1%	26	30	40	STD	IN, BR	MM0369434
SLS45x75	10.5	45	16	37.1%	31.6%	31	45	60	XHD	SE	MM0360387
SLS45x95	8.5	50	20	53.5%	45.6%	20	27.8	60	HD	SE	MM0364908
SLS50x95	8.6	50	15+5	54.1%	43.4%	21.5	27.8	60	HD	BR	MM0372274
SLS60x110	8.8	45	12	52.1%	42.6%	24.5	40	60	HD	US, SE	MM0375720
SLS90/60x110M	10	55/45	6+3	47.1%	42.6%	24.5	40	60	XHD	SE	MM0380356
SLS90x110	10	55	8	47.1%	42.6%	50	40	60	XHD	SE	MM0378508
STS46x100	8.3	45	16	45.4%	39.6%	37	28	60	HD	US	MM0431876

Other apertures on request.

SLS = With flow, STS = Cross flow

Can be manufactured with soft flex rubber 40° shore hardness upon request, see Trellex LS HiPer Clean. Always check with Metso representative if suitable.

* LD = Light Duty
STD = Standard Duty
HD = Heavy Duty
XHD = Extra Heavy Duty

Trellex LS Wedge wire

Wedge wire LS modules

Stainless steel - standard modules

Trellex 305LS-610

Slot Direction	Hole type (mm)	Relative open area (%)	Effective open area (%)	Build height (mm)	Part No.
With Flow	0.3	11.5	9.4	40	MM0371173
With Flow	0.5	17.9	14.6	40	MM0400074
With Flow	0.75	24.6	20.5	40	MM0427639
With Flow	1.0	30.3	24.8	40	
With Flow	1.25	32.2	28.8	40	
Cross Flow	0.65	22.0	18.0	40	MM0424280
Cross Flow	0,75	24.6	20.2	40	MM0424281

Trellex 610LS-305 - light duty

Slot Direction	Hole type (mm)	Relative open area (%)	Effective open area (%)	Build height (mm)	Part No.
With Flow	1.8LD	44	37	40	9260010400022
With Flow	1.4LD	38	32	40	9260010400023
With Flow	1.0LD	30	26	40	9260010400024
With Flow	0.75LD	25	21	40	9260010400025
With Flow	0.5LD	18	15	40	9260010400026
With Flow	1.25LD	35	30	40	9260010400061

Trellex 610LS-305 - heavy duty

Slot Direction	Hole type (mm)	Relative open area (%)	Effective open area (%)	Build height (mm)	Part No.
With Flow	0.75 HD	20	17	40	9260010400003
With Flow	1.4 HD	31	26	40	9260010400018
With Flow	1.0 HD	25	21	40	9260010400019
With Flow	1.8 HD	37	31	40	9260010400020
With Flow	0.5 HD	14	12	40	9260010400021
With Flow	1.25 HD	29	24	40	9260010400038

Trellex 711LS-305 - light duty

Slot Direction	Hole type (mm)	Relative open area (%)	Effective open area (%)	Build height (mm)	Part No.
With Flow	0.5 LD	18	15	40	ZX11196289
With Flow	0.75 LD	25	21	40	ZX11196290
With Flow	1.0 LD	30	26	40	ZX11196304
With Flow	1.25 LD	35	30	40	ZX11196305
With Flow	1.4 LD	38	32	40	ZX11196306
With Flow	1.8 LD	44	37	40	ZX11196307

Trellex 711LS-305 - heavy duty

Slot Direction	Hole type (mm)	Relative open area (%)	Effective open area (%)	Build height (mm)	Part No.
With Flow	0.5HD	14	12	40	ZX11193647
With Flow	0.75HD	20	17	40	ZX11196284
With Flow	1.0HD	25	21	40	ZX11196285
With Flow	1.25HD	29	24	40	ZX11196286
With Flow	1.4HD	31	26	40	ZX11196287
With Flow	1.8HD	37	31	40	ZX11196288



Trellex LS HiPer range

Trellex LS HiPer range

Give your screen the **highest performance** upgrade possible. HiPer is our most advanced product line, grouped into four top-performing series offering even more capacity, more efficient material screening and zero interruptions caused by pegging or blinding. Since they're designed, produced and delivered by Metso, you can plan your screening media system with a mix of Trellex LS standard and HiPer modules for maximum effectiveness and value.

Trellex LS HiPer Flow

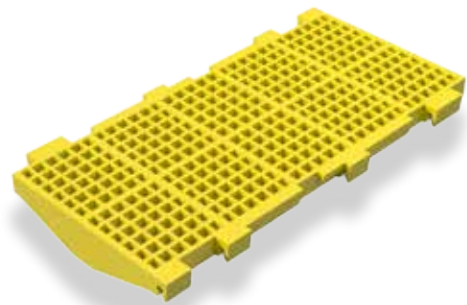

Trellex LS HiPer Flow modules have at least 20% more effective open area compared to corresponding LS standard modules. In performance terms, that means you get **at least 20% more active screening surface**. But LS HiPer Flow is much more than just an increased number of holes per module. It has been specially engineered using

dual hardness technology to ensure that the wider and more productive open area does not come at the expense of wear life. Combining LS HiPer Flow modules with LS Standard modules makes it possible to further optimize the flow, getting the most out of the screen application.

Trellex LS HiPer Life

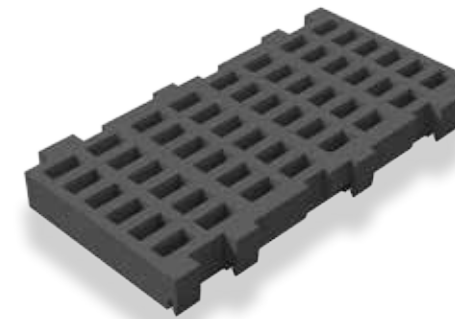

Trellex LS HiPer Life is built tough for maximum load handling to offer exceptional wear resistance. The unique combination of injection-molded modules with molded apertures and rubber ensures high wear resistance and long wear life. Trellex LS HiPer Life modules **last at least 30% longer** compared to standard LS. The LS HiPer

Life modules are ideal for use in complete deck or in combination with LS standard modules for the highest possible cost effectiveness.

Trellex LS HiPer Clean

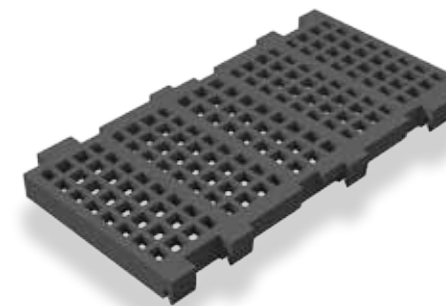

Trellex LS HiPer Clean modules deliver the precision you need when screening fine materials while limiting costly downtime. The unique combination of injection-molded modules with molded apertures and superior flexible rubber material ensures high efficiency with less pegging and blinding. LS HiPer Clean modules **stay clean in the most challenging conditions**, including

during screening of high humidity materials. Injection mold manufacturing technology ensures consistent material performance properties across the board. The ultra-flexible membrane material rotates effectively, increasing throughput of fines. The result is precision production without interruptions. Also available in 60° hardness for higher load capacity.

Trellex LS HiPer Drain

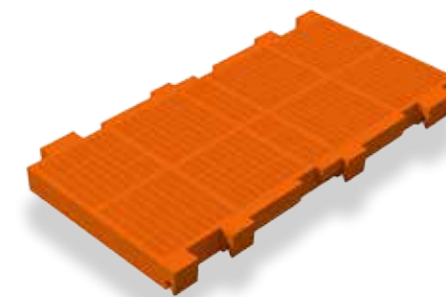

With Trellex LS HiPer Drain, you can count on precision performance and exceptional dewatering. All modules are made from injection-molded polyurethane with the highest possible accuracy in aperture size and module dimensions. That means higher screening precision and minimum risk of leakage. All openings are optimized

to give the highest possible dewatering efficiency. In order to cope with these tough applications, and with high bed depths, each module has a strong, reinforcing frame. Choose Trellex LS HiPer Drain when you want the **highest possible precision in your dewatering application**.

Trellex LS HiPer Range

Trellex LS HiPer Flow

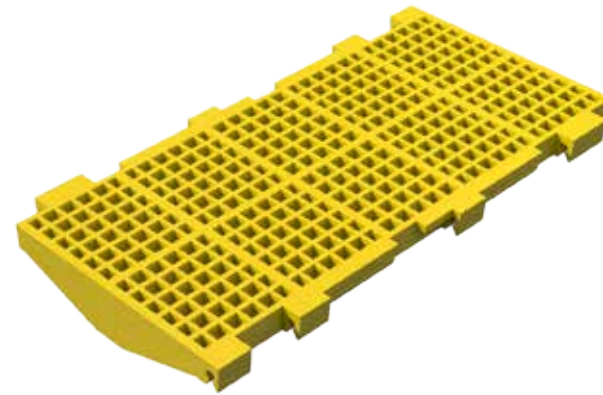

- At least 20% more active screening surface compared to standard
- More molded apertures on every module
- Saves time and money
More open area = more material processed
- Long-lasting, dual durometer open cast polyurethane design
- Lightweight, no steel frames, recyclable

Trellex LS HiPer Flow

Trellex 300LS-500 PU

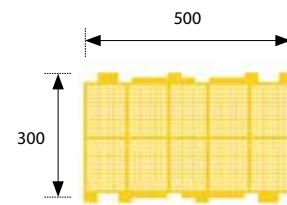

Hole type	Module weight (kg)	Thickness screen area (mm)	Quantity apertures per panel	Relative open area (%)	Effective open area (%)	Min web thickness with flow (mm)	Min web thickness cross flow (mm)	Build height (mm)	Part No. 75/90 (Sh-D/Sh-A)	Part No. 75/80 (Sh-D/Sh-A)
FR3.5EX	2.05	4	3680	41.2	30.0	2	2	30	6681239	6681238
FR5EX	2.08	5	2160	50.0	36.0	2	2.2	30	6681241	6681240
FR6EX	2.09	6	1560	51.0	37.4	2.4	2.4	30	6681245	6681244
FR7EX	2.1	7	1144	49.0	37.8	2.8	3.2	30	MM0365380	MM0365379
FR8EX	2.09	8	960	53.9	41.0	2.6	3.2	30	6681249	6681248
FR9EX	2.14	9	792	54.2	41.5	3	3.5	30	6681251	6681250
FR10EX	2.2	10	640	54.9	42.7	3	4.2	30	6681253	6681252
FR13EX	2.43	15	392	51.4	41.3	4.3	6	30	Non standard	6681519
FR15EX	2.22	15	336	58.9	46.6	5	4.1	30		MM0354039
FR16EX	2.51	20	288	55.2	44.0	6.2	4.9	30		MM0354037
FR18EX	2.68	20	200	49.5	41.3	6.25	9	30		6681515
FR22EX	2.47	20	160	56.6	46.5	7	7.5	30		MM0354035
FR25EX	2.66	25	128	58.7	48.0	8.5	6.8	30		MM0365341

Other apertures on request.

Trellex LS HiPer Flow

Trellex 300LS-610 PU

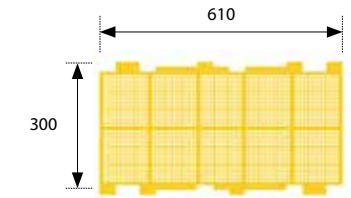

Hole type	Module weight (kg)	Thickness screen area (mm)	Quantity apertures per panel	Relative open area (%)	Effective open area (%)	Min web thickness with flow (mm)	Min web thickness cross flow (mm)	Build height (mm)	Part No. 75/90 (Sh-D/Sh-A)	Part No. 75/80 (Sh-D/Sh-A)
FR3.5EX	2.46	4	4508	41.2	30.2	2	2	30	6681255	6681254
FR5EX	2.45	5	2664	50.0	36.4	2	2.2	30	6681257	6681256
FR6EX	2.47	6	1920	51.0	37.8	2.4	2.4	30	6681261	6681260
FR7EX	2.51	7	1404	49.0	37.6	2.8	3.2	30	MM0365382	MM0365381
FR8EX	2.52	8	1176	53.9	41.1	2.6	3.2	30	6681265	6681264
FR9EX	2.55	9	990	54.2	41.6	3	3.5	30	6681267	6681266
FR10EX	2.64	10	800	54.9	42.6	3	4.2	30	6681269	6681268
FR13EX	2.92	15	476	51.4	41.6	4.3	6	30	Non standard	6681520
FR15EX	2.66	15	420	58.9	46.8	5	4.1	30		MM0354040
FR16EX	2.98	20	348	55.2	44.5	6.2	5.7	30		MM0354038
FR18EX	3.28	20	250	49.5	40.9	6.25	9	30		6681516
FR22EX	2.94	20	200	56.6	47.2	7	7.5	30		MM0354036
FR25EX	3.26	25	160	58.7	47.5	8.5	6.8	30		MM0369332

Other apertures on request.

Trellex LS HiPer Flow

Trellex 305LS-610 PU

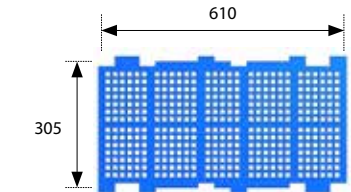

Hole type	Module weight (kg)	Thickness screen area (mm)	Quantity apertures per panel	Relative Open Area (%)	Effective Open Area (%)	Min web thickness with flow (mm)	Min web thickness cross flow (mm)	Build height (mm)	Part No. 75/90 (Sh-D/Sh-A)	Part No. 75/80 (Sh-D/Sh-A)	
FR3.5EX	2.57	4	4508	41.2	29.7	2	2	30	6681227	6681226	
FR5EX	2.56	5	2664	50.0	35.8	2	2.2	30	6681229	6681228	
FR6EX	2.58	6	1920	51.0	37.2	2.4	2.4	30	6681230	6681231	
FR7EX	3.62	7	1404	49.0	37.0	2.8	3.2	30	MM0429457		
FR8EX	2.63	8	1176	53.9	40.4	2.6	3.2	30	6681232	6681233	
FR9EX	2.66	9	990	54.2	10.9	3	3.5	30	6681235	6681234	
FR10EX	2.75	10	800	54.9	41.9	3	4.2	30	6681237	6681236	
FR13EX	3.03	15	476	51.4	40.9	4.3	6	30	Non standard	6681636	
FR15EX	2.77	15	420	58.9	46.8	5	4.1	30		MM0361927	
FR16EX	3.09	20	348	55.2	44.5	6.2	5.7	30		MM0361928	
FR18EX	3.39	20	250	49.5	40.2	6.25	9	30		6681637	
FR22EX	3.05	20	200	56.6	47.2	7	7.5	30		MM0361929	
FR25EX	3.37	25	160	58.7	46.7	8.5	6.8	30			

Other apertures on request.

Trellex LS HiPer range

Trellex LS HiPer Life

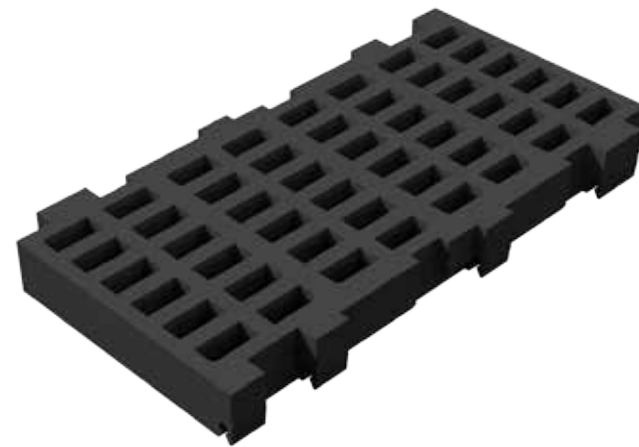

- Built tough for maximum load handling
- Injection-molded wear-resistant rubber compound – lasts at least 30% longer!
- Molded aperture reduces risk of pegging
- Higher temperature resistance

Trellex LS HiPer Life

Trellex 300LS-610

Rubber 60° Shore A, injection molded apertures

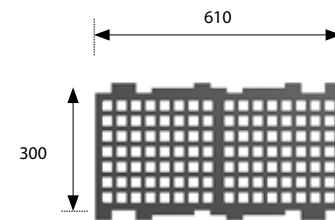

Hole type	Module weight (kg)	Thickness screen area (mm)	Quantity apertures per panel	Relative open area (%)	Effective open area (%)	Min web thickness with flow (mm)	Min web thickness cross flow (mm)	Build height (mm)	Manufacturing country	Part No.
FR14M	4.8	20	288	42.0	30.8	7	7.6	40		MM0360948
FR55M	7.1	45	24+8	56.0	45.7	18.5	18.5	60	SE	MM0360949
FR64M	7.4	35	18	48.6	40.3	22	34	60	SE	6681079
SLS25x78M	5.7	35	36	44.3	38.4	19	22	40	SE	MM0360950
SLS9.5x32M	8.2	35/45	168	37.9	27.9	8.5	12.6	60		MM0371969
SLS12.5x27.5M	10.7	45	143	39.0	26.9	10	12	60	SE	MM0360951
SLS25x54	8.6	45	48	43.2	35.4	18.5	18	60	SE	MM0371973
SLS35x105M	10.2	45	16	37.1	32.1	31	45	60	BR, SE	MM0360954
SLS45x75M	6.6	45	24	51.4	44.3	20.6	25.1	60	BR, SE	MM0361384
SLS45x95M	8.3	50	20	53.5	45.6	20	27.8	60	SE	MM0371974
SLS60x110M	9.5	45	12	42.1	43.3	24.5	40	60	SE	
SLS90x110M	9.8	55	8	47.1	43.3	50	40	60	SE	

Other apertures on request.
SLS = With flow, STS = Cross flow

Trellex LS HiPer Life

Trellex 305LS-610

Rubber 60° Shore A, injection molded apertures

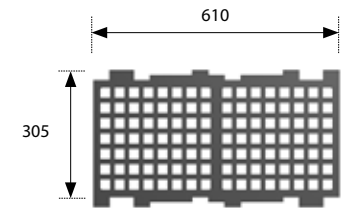

Hole type	Module weight (kg)	Thickness screen area (mm)	Quantity apertures per panel	Relative open area (%)	Effective open area (%)	Min web thickness with flow (mm)	Min web thickness cross flow (mm)	Build height (mm)	Manufacturing country	Part No.
FR14M	4.9	20	288	42.0%	30.3%	7	7.6	40	SE	MM0354295
FR55M	7.3	45	24+8	56.0%	44.9%	18.5	18.5	60	SE	MM0360943
FR64M	7.6	35	18	48.6%	39.6%	22	34	60	SE	6681080
SLS5x17.5M	4.2	10	624	40.5%	29.3%	4.7	4.9	40	IN, SE	MM0347093
SLS8x28.5M	5.2	20	254	41.9%	30.2%	6.9	8	40	BR, US, SE	MM0413713
SLS9.5x32M	8.2	35/45	168	37.9%	27.5%	8.5	12.6	60	SE	MM0371975
SLS10x25-MKII	5.1	20	210	36.3%	27.2%	8.1	13	40	IN, BR	MM0422519
SLS12.5x27.5M	5.5	25	180	44.6%	32.1%	8.6	9	40	IN, BR, US, SE	MM0352279
SLS12.5x27.5M	11	45	143	39.0%	26.2%	10	12	60	US, SE	MM0360946
SLS20x40M	5.7	30	80	42.5%	33.5%	11.9	16	40	IN, US, SE	MM0416879
SLS25x57M	5.8	35	56	53.4%	42.9%	11.8	15	40	BR, US, SE	MM0420464
SLS25x78M	5.9	35	36	44.3%	37.7%	19	22	40	SE	MM0360944
SLS25x54M	8.8	45	48	43.2%	34.9%	18.5	18	60	BR, SE	MM0371976
SLS30x65M	9.3	55	30	37.5%	31.4%	22	35	60	IN	
SLS35x105M	10.5	45	16	37.1%	31.6%	31	45	60	SE	MM0360947
SLS36x65M	9.3	55	24	35.7%	30.2%	29.5	35	60	IN, US	MM0413717
SLS45x75M	6.8	45	24	51.4%	43.5%	20.6	25.1	60	SE	MM0361419
SLS45x95M	8.5	50	20	53.5%	45.6%	20	27.8	60	SE	MM0371977
SLS60x110M	9.7	45	12	52.1%	42.6%	24.5	40	60	US, SE	MM0420463
SLS90x110M	10	55	8	47.1%	42.6%	50	40	60	SE	

Other apertures on request.
SLS = With flow
STS = Cross flow

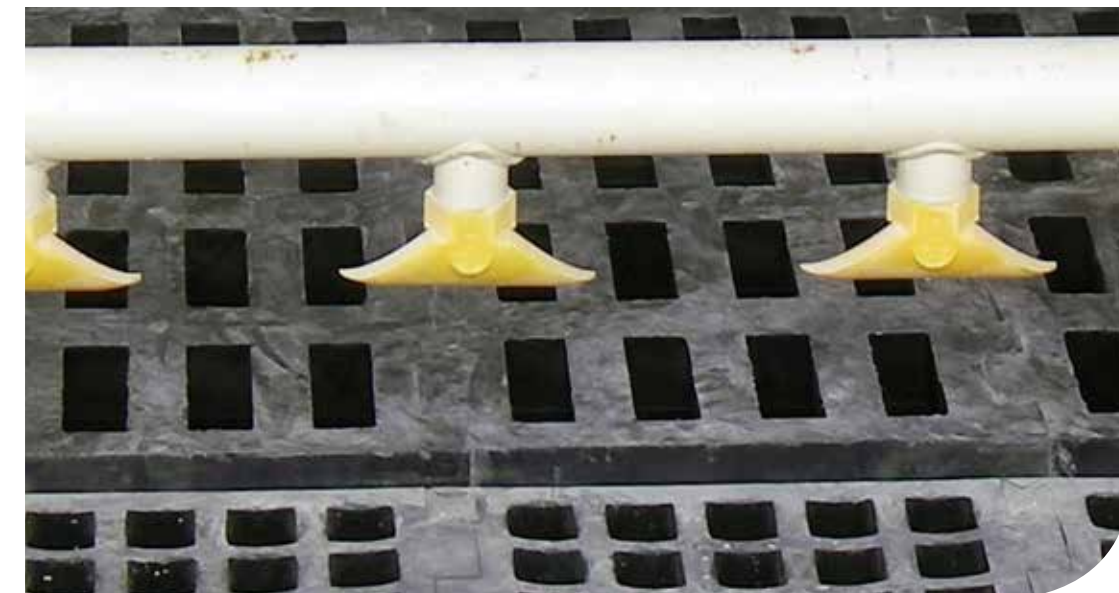

HiPer Life modules on FS-screen in feed end to handle impact with better life time.

Trellex LS HiPer range

Trellex LS HiPer Clean

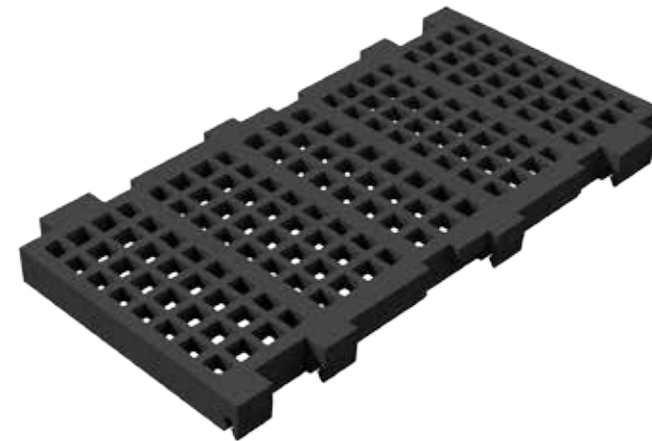

- Precision production without interruption
- Flexible membrane and molded apertures prevent blinding and pegging
- GUARANTEED to stay clean, even with high-moisture material
- Injection-molded flexible rubber construction ensures consistent material performance properties across the board
- Highly accurate, ideal for finer separations



Trellex LS HiPer Clean

Trellex 300LS-500

Rubber 40° Shore A, injection molded apertures

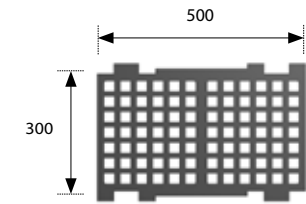

Hole type	Module weight (kg)	Thickness screen area (mm)	Quantity apertures per panel	Relative open area (%)	Effective open area (%)	Min web thickness with flow (mm)	Min web thickness cross flow (mm)	Build height (mm)	Design*	Manufacturing country	Part No.
FR3.2	2.5	4	2880	27.5%	19.7%	2.8	3	30	LD	SE	6670600
FR4.0	2.5	4	2040	30.4%	21.8%	3.2	3.3	30	LD	SE	6670602
FR4.8	2.5	4	1479	31.5%	22.7%	3.7	3.8	30	LD	SE	6670604
FR4.8-MKII	2.8	5	1508	32.3%	23.2%	3.8	3.5	30	STD	SE	MM0421431
FR4.8-MKII	3.2	5	1508	32.3%	23.2%	3.8	3.5	30	STD	SE	MM0421438
FR5.4	2.5	5	1296	34.8%	25.2%	3.6	3.9	30	LD	SE, BR	6670606
FR5.4-MKII	2.8	5	1296	35.2%	25.2%	3.9	3.5	30	STD	SE	MM0421463
FR5.4-MKII	3.2	5	1296	35.2%	25.2%	3.9	3.5	40	STD	SE	MM0421470
FR6.5	2.5	5	1008	42.3%	28.4%	3.5	3.5	30	LD	SE, BR	6670608
FR8.5	2.4	6	720	47.0%	34.6%	3.7	4	30	LD	SE, BR	6670655
FR10	3.2	12	448	41.6%	29.9%	5.7	5.3	30	STD	SE, BR	MM0371190
FR10	3.6	12	448	41.6%	29.9%	5.7	5.3	40	STD	SE, BR	MM0371192
FR12	2.7	12	336	43.0%	32.3%	6.6	6	30	LD	SE	6670695
FR12-MKII	3.1	12	336	44.4%	32.3%	6	6	30	STD	BR	MM0375168
FR12-MKII	3.5	12	336	44.4%	32.3%	6	6	40	STD	BR	MM0375170
FR13	3.1	12	312	45.8%	32.4%	6.4	6	30	STD	SE	MM0345239
FR13	3.5	12	312	45.8%	32.4%	6.4	6	40	STD	SE	MM0345261
FR14	3.6	20	240	30.3%	31.4%	7	7.6	30	STD	SE	MM0345242
FR14	4	20	240	30.3%	31.4%	7	7.6	40	STD	SE	MM0345243
FR16	3.5	20	220	50.0%	35.7%	6.3	6.9	30	STD	SE	MM0353390
FR16	3.9	20	220	50.0%	35.7%	6.3	6.9	40	STD	SE	MM0353395
FR18	3.6	20	160	45.7%	34.6%	10	7.3	30	STD	SE	MM0353611
FR18	4	20	160	45.7%	34.6%	10	7.3	40	STD	SE	MM0353609
FR20-MK2	3.8	20	144	52.9%	38.4%	8	7	40	STD	SE	MM0424541
FR22	3.5	20	128	50.7%	36.1%	9.85	8	30	STD	SE	MM0361784
FR22	3.9	20	128	50.7%	36.1%	9.85	8	40	STD	SE	MM0361768
FR25HD	4.4	30	84	46.4%	35.0%	11.4	12	40	STD	SE	MM0361783
SLS3x12.5	2.7	8	960	33.4%	24.0%	3.3	5.3	30	STD	SE	MM0407865
SLS3x12.5	3.1	8	960	33.4%	24.0%	3.3	5.3	40	STD	SE	MM0407866
SLS8x28.5	3.6	20	204	41.9%	31.0%	6.9	8	30	STD	SE	MM0353489
SLS8x28.5	4.1	20	204	41.9%	31.0%	6.9	8	40	STD	SE	MM0353505
SLS10x25-MKII	3.7	20	168	36.3%	28.0%	8.1	13	30	STD	SE	MM0393629
SLS10x25-MKII	4.1	20	168	36.3%	28.8%	8.1	13	40	STD	SE	MM0393628
SLS12.5x27.5	3.9	25	144	44.6%	33.0%	8.6	9	30	STD	SE	MM0353408
SLS12.5x27.5	4.3	25	144	44.6%	33.0%	8.6	9	40	STD	SE	MM0353396
SLS16x44	3.6	25	80	49.6%	37.5%	9.4	12	30	STD	SE	MM0371517
SLS16x44	4	25	80	49.6%	37.5%	9.4	12	40	STD	SE	MM0371513
SLS20x40	4.5	30	64	42.5%	34.1%	11.9	19	40	STD	SE	MM0357215

Other apertures on request.
 Also available in 60° shore for higher load capacity.
 SLS = With flow, STS = Cross flow

Trellex LS HiPer Clean

Trellex 300LS-610

Rubber 40° Shore A, injection molded apertures

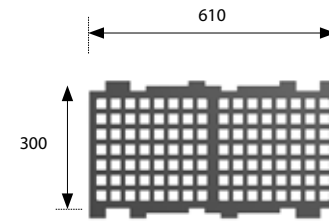

Hole type	Module weight (kg)	Thickness screen area (mm)	Quantity apertures per panel	Relative open area (%)	Effective open area (%)	Min web thickness with flow (mm)	Min web thickness cross flow (mm)	Build height (mm)	Design*	Manufacturing country	Part No.
FR3.2	2.9	4	3360	26.3%	18.8%	3	2.8	30	LD	SE	6670622
FR4.8	2.9	4	1740	31.5%	21.9%	3.8	3.7	30	LD	SE	6670637
FR4.8-MKII	3.4	5	1798	32.3%	22.6%	3.8	3.5	30	STD	SE	MM0421434
FR4.8-MKII	3.9	5	1798	32.3%	22.6%	3.8	3.5	40	STD	SE	MM0421455
FR5.4	3	5	1512	34.8%	24.1%	3.9	3.6	30	LD	SE, BR	6670657
FR5.4-MKII	3.4	5	1566	35.2%	25.0%	3.9	3.5	30	STD	SE	MM0421466
FR5.4-MKII	3.9	5	1566	35.2%	25.0%	3.9	3.5	40	STD	SE	MM0421472
FR6.5	2.9	5	1248	39.8%	28.8%	4	3.6	30	LD	SE, BR	6670626
FR8.5	2.9	6	880	47.8%	34.7%	4	3.6	30	LD	SE, BR	6670656
FR10	3.8	12	544	41.6%	29.7%	5.7	5.3	30	STD	SE, BR	MM0371180
FR10	4.3	12	544	41.6%	29.7%	5.7	5.3	40	STD	SE, BR	MM0371185
FR12	3.4	12	392	41.0%	30.8%	6	7.5	30	LD	SE	6670697
FR12-MKII	3.8	12	406	44.4%	31.9%	6	6	30	STD	BR	MM0375163
FR12-MKII	4.3	12	406	44.4%	31.9%	6	6	40	STD	BR	MM0375165
FR13	3.8	12	377	45.8%	32.0%	6.4	6	30	STD	SE	MM0345240
FR13	4.2	12	377	45.8%	32.0%	6.4	6	40	STD	SE	MM0345262
FR14	4.3	20	288	30.3%	30.8%	7	7.6	30	STD	SE	MM0345288
FR14	4.8	20	288	30.3%	30.8%	7	7.6	40	STD	SE	MM0345289
FR16	4.3	20	264	50.0%	35.4%	6.9	6.3	30	STD	SE, BR	MM0353392
FR16	4.8	20	264	50.0%	35.4%	6.9	6.3	40	STD	SE, BR	MM0353399
FR18	4.4	20	200	45.7%	34.1%	10	7.3	30	STD	SE, BR	MM0353679
FR18	4.9	20	200	45.7%	34.1%	10	7.3	40	STD	SE, BR	MM0353677
FR20-MK2	4.6	20	162+18	52.9%	38.2%	8	7	40	STD	SE	MM0424534
FR22	4.2	20	152	50.7%	36.0%	9.85	8	30	STD	SE, BR	MM0361788
FR22	4.7	20	152	50.7%	36.0%	9.85	8	40	STD	SE, BR	MM0361800
FR25HD	5.4	30	98+7	46.4%	34.7%	11.4	12	40	HD	SE, BR	MM0361802
SLS3x12.5	3.3	8	1160	33.4%	23.3%	3.3	5.3	30	STD	SE	MM0406277
SLS3x12.5	3.7	8	1160	33.4%	23.3%	3.3	5.3	40	STD	SE	MM0406278
SLS5x17.5	4	10	624	40.5%	29.8%	4.7	4.9	40	STD	SE	MM0345236
SLS8x28.5	4.4	20	254	41.9%	30.7%	6.9	8	30	STD	SE, BR	MM0353508
SLS8x28.5	4.9	20	254	41.9%	30.7%	6.9	8	40	STD	SE, BR	MM0353514
SLS10x25M-MKII	4.5	20	210	36.3%	27.7%	8.1	13	30	STD	BR	MM0393632
SLS10x25M-MKII	5	20	210	36.3%	27.7%	8.1	13	40	STD	BR	MM0393633
SLS10x25	5.2	25	224	40.0%	30.6%	8.1	9.5	40	STD	SE	MM0345244
SLS12.5x27.5	4.7	25	180	44.6%	32.7%	8.6	9	30	STD	SE, BR	MM0353401
SLS12.5x27.5	5.2	25	180	44.6%	32.7%	8.6	9	40	STD	SE, BR	MM0353405
SLS14x56	5.2	25	80	43.3%	34.3%	11.5	15	40	STD	SE	MM0363503
SLS16x44	4.4	25	100	49.7%	31.2%	9.4	12	30	STD	SE, BR	MM0371592
SLS16x44	4.9	25	100	49.7%	31.2%	9.4	12	40	STD	SE, BR	MM0371590
SLS20x40	5.4	30	80	42.5%	34.1%	11.9	16	40	STD	SE	MM0361804
SLS25x57	5.6	35	56	53.4%	43.6%	11.8	15	40	STD	SE, BR	MM0361805

Other apertures on request. Also available in 60° shore for higher load capacity.
 SLS = With flow
 STS = Cross flow
 * LD = Light Duty
 STD = Standard Duty
 HD = Heavy Duty
 XHD = Extra Heavy Duty

Trellex LS HiPer Clean

Trellex 305LS-610

Rubber 40° Shore A, injection molded apertures

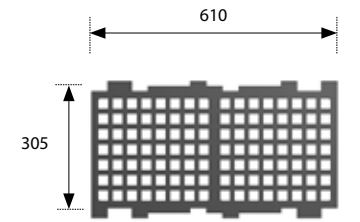

Hole type	Module weight (kg)	Thickness screen area (mm)	Quantity apertures per panel	Relative open area (%)	Effective open area (%)	Min web thickness with flow (mm)	Min web thickness cross flow (mm)	Build height (mm)	Design*	Manufacturing country	Part No.
FR3.2	2.9	4	3360	26.3%	18.5%	3	2.8	30	LD	SE	6670624
FR4.8	3	4	1740	31.5%	21.5%	3.8	3.7	30	LD	SE	6670630
FR4.8-MKII	3.5	5	1798	32.3%	22.3%	3.8	3.5	30	STD	SE	MM0421436
FR4.8-MKII	4	5	1798	32.3%	22.3%	3.8	3.5	40	HD	SE	MM0421460
FR5.4	3.1	5	1512	34.8%	23.7%	3.9	3.6	30	LD	SE, BR	6670721
FR5.4-MKII	3.6	5	1566	35.2%	24.5%	3.9	3.5	30	STD	SE	MM0421468
FR5.4-MKII	4.1	5	1566	35.2%	24.5%	3.9	3.5	40	HD	SE	MM0421475
FR6.5	3	5	1248	39.8%	28.3%	4	3.6	30	LD	SE, BR	6670628
FR8.5	3	6	880	47.8%	20.0%	4	3.6	30	LD	SE, BR	6681010
FR10	4	12	544	41.6%	29.2%	5.7	5.3	30	STD	IN, SE, BR	MM0371183
FR10	4.6	12	544	41.6%	29.2%	5.7	5.3	40	STD	IN, SE, BR	MM0371187
FR12M-MKII	4	12	406	44.4%	31.4%	6	6	30	STD	IN, US, BR	MM0369435
FR12M-MKII	4.5	12	406	44.4%	31.4%	6	6	40	STD	IN, US, BR	MM0369437
FR12	3.4	12	392	41.0%	30.3%	6	7.5	30	STD	SE	6670699
FR13	4	12	377	45.8%	31.5%	6.4	6	30	STD	SE	MM0345241
FR13	4.4	12	377	45.8%	31.5%	6.4	6	40	STD	SE	MM0345263
FR14	4.4	20	288	30.3%	43.2%	7	7.6	30	STD	SE	MM0345249
FR14	4.9	20	288	30.3%	43.2%	7	7.6	40	STD	SE	MM0345250
FR16	4.5	20	264	50.0%	34.8%	6.9	6.3	30	STD	SE, IN, BR	MM0353290
FR16	5	20	264	50.0%	34.8%	6.9	6.3	40	STD	SE, IN, BR	MM0353404
FR18	4.6	20	200	45.7%	33.6%	10	7.3	30	STD	SE, US, BR	MM0353418
FR18	5.1	20	200	45.7%	33.6%	10	7.3	40	STD	SE, US, BR	MM0353419
FR20M-MK2	4.8	20	180	52.9%	37.5%	8	7	40	STD	SE	MM0424538
FR22	4.9	20	152	50.7%	35.4%	9.85	8	40	STD	SE, BR	MM0361817
FR22	4.2	25	112	48.4%	37.6%	11.3	10.6	40	STD	SE, BR	MM0361815
FR25HD	5.6	30	98+7	46.4%	34.1%	11.4	12	40	HD	SE, US, BR	MM0361813
SLS3x12.5	3.5	8	1160	33.4%	23.3%	3.3	5.3	30	STD	SE	MM0407801
SLS3x12.5	3.9	8	1160	33.4%	23.3%	3.3	5.3	40	STD	SE	MM0405438
SLS5x17.5	4.2	10	624	40.5%	29.3%	4.7	4.9	40	STD	IN, SE	ZX11155529
SLS8x28.5	4.6	20	254	41.9%	30.2%	6.9	8	30	STD	IN, BR, US, SE	MM0353417
SLS8x28.5	5.2	20	254	41.9%	30.2%	6.9	8	40	STD	IN, BR, US, SE	MM0353416
SLS10x25M-MKII	4.7	20	210	36.3%	27.2%	8.1	13	30	STD	IN, BR, US	MM0369445
SLS10x25M-MKII	5.1	20	210	36.3%	27.2%	8.1	13	40	STD	IN, BR, US	MM0369447
SLS10x25	5.3	25	224	40.0%	30.1%	8.1	9.5	40	STD	SE	6670891
SLS12.5x27.5	4.9	25	180	44.6%	32.1%	8.6	9	30	STD	IN, BR, US, SE	MM0353292
SLS12.5x27.5	5.5	25	180	44.6%	32.1%	8.6	9	40	STD	IN, BR, US, SE	MM0353288
SLS16x44	4.6	25	100	30.7%	49.7%	9.4	12	30	STD	IN, BR, SE	MM0369441
SLS16x44	5.1	25	100	30.7%	49.7%	9.4	12	40	STD	IN, BR, SE	MM0369443
SLS20x40	5.7	30	80	42.5%	33.5%	11.9	16	40	STD	IN, US, SE	MM0361818
SLS25x57	5.8	35	56	53.4%	42.9%	11.8	15	40	STD	BR, US, SE	MM0349197
SLS25x78	5.9	35	36	44.3%	37.7%	19	22	40	HD	SE	MM0353415

Other apertures on request. Also available in 60° shore for higher load capacity.
 SLS = With flow
 STS = Cross flow
 * LD = Light Duty
 STD = Standard Duty
 HD = Heavy Duty
 XHD = Extra Heavy Duty

Trellex LS HiPer Range

Trellex LS HiPer Drain

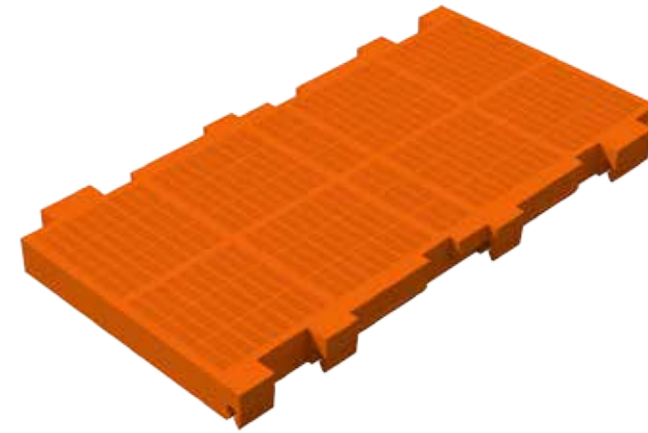

- Precision-crafted injection mold polyurethane modules
- Accuracy-optimized molded apertures 0.3x11 – 0.8x11
- Solid, reinforced frames to carry high bed depth
- Available with slotted apertures
- Max bed depth 100-150 mm at bulk density at 1.6 t/m³

Trellex LS HiPer Drain

Trellex 305LS-610

TPU 90 Shore A, injection molded apertures

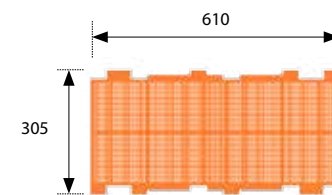

Hole type	Module weight (kg)	Thickness screen area (mm)	Quantity apertures per panel	Relative open area (%)	Effective open area (%)	Min web thickness with flow (mm)	Min web thickness cross flow (mm)	Build height (mm)	Part No.
SLS 0.3x11	5.5	8	3510	8.6	6.3	2.45	2.9	40	6641676
SLS 0.5x11	5.6	8	3276	13.4	9.8	2.45	2.9	40	6641678
SLS 0.63x11	5.5	8	3120	16.1	11.7	2.45	2.9	40	6641680
SLS 0.8x11	5.5	8	2886	19.2	13.8	2.5	2.9	40	6641682
STS 0.3x11	5.6	8	3528	8.6	6.3	2.9	2.45	40	6641677
STS 0.5x11	5.6	8	3276	13.4	9.7	2.9	2.45	40	6641679
STS 0.63x11	5.6	8	3132	16.2	11.7	2.9	2.45	40	6641681
STS 0.8x11	5.5	8	2880	19.2	13.6	2.9	2.5	40	6641683

Other apertures upon request.
SLS = With flow, STS = Cross flow

Trellex LS-S side modules

Trellex LS-S side modules

Side modules are available in a wide range of widths to complete installations on both metric and imperial screens. Available in widths between 100-400 mm.

The following pages outline side module configurations suited for Metso screens.

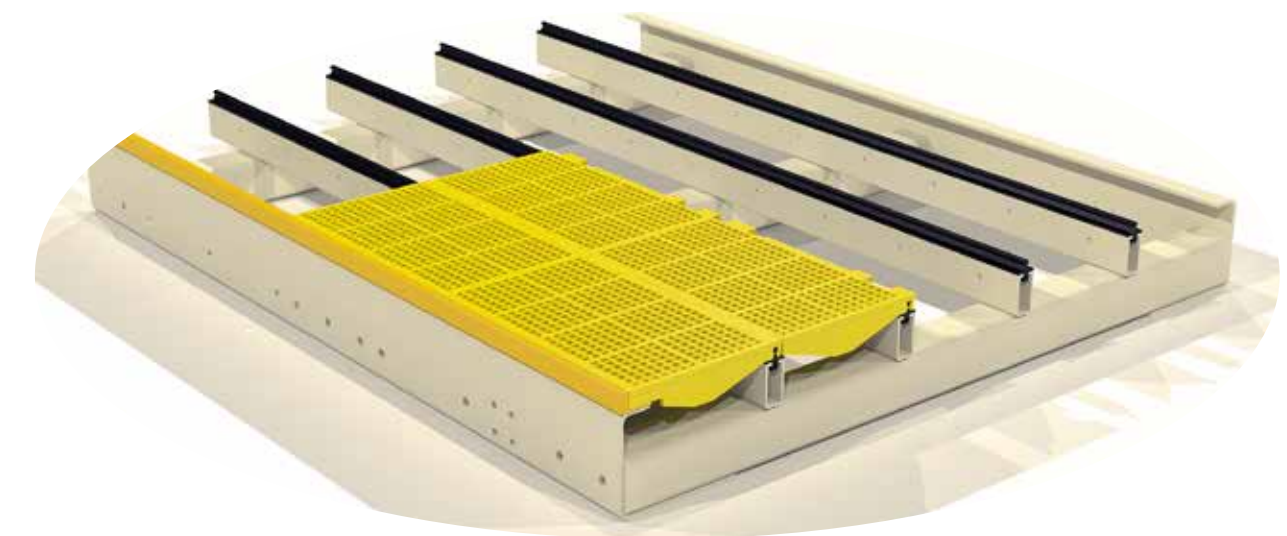

Trellex LS-S PU side modules

Trellex LS-S-500

Machined/PU-cast from standard modules (FR)

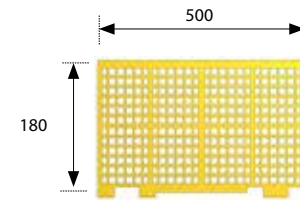

LS-S-180-500-FR-PU

Hole type	Side Module Width (mm)	Thickness screen area (mm)	Min web thickness with flow (mm)	Min web thickness cross flow (mm)	Build height (mm)	Part No. 75/90 (Sh-A) *	Part No. 75/80 (Sh-A) *
FR2.5	180	6	3	3	30		
FR3	180	4	2.5	2.5	30		
FR3HD	180	6	3.5	3.5	30		
FR3.5	180	5	2.5	2.9	30		
FR4	180	5	2.6	2.6	30		
FR5	180	5	2.7	2.7	30		
FR5HD	180	9	4	4	30		
FR5.5	180	7	3.5	3.5	30		
FR5.5HD	180	12	4	4	40		
FR6	180	6	3.4	3.4	30		
FR6HD	180	10	5	5	30		
FR6.5	180	6	3.5	3.5	30		
FR6.5HD	180	14	4.5	4.5	40		
FR7	180	6	3.2	3.2	30		
FR8	180	9	3.6	4.5	30		
FR9	180	9	4	5	30	ZX11193989	
FR9HD	180	20	10	9	30		
FR10	180	10	5	5	30		6681007.78
FR11	180	10	6	4.5	30	Non standard	
FR12	180	12	6	6	30		
FR13	180	12	5.2	8	30		
FR13HD	180	25	8.5	9.5	30		
FR14	180	15	8	8	30		
FR15	180	15	7	7	30		
FR16	180	20	6.5	6.5	30		
FR17	180	20	8	9	30		
FR18	180	20	10	10	30		
FR19	180	20	9.5	9.5	30		6681006
FR20	180	20	8.5	8.5	30		
FR21	180	20	11	11	30		
FR22	180	20	10	11	30		
FR23	180	20	9.5	9.5	30		
FR24	180	25	12	12	30		
FR25	180	25	11	11	30	6681509	
FR26	180	25	10	12	30		
FR27	180	30	9	12	30		
FR28	180	30	15.5	15	30		
FR36	180	25	17	17	40		
FR36	180	25	17	17	30		
FR44	180	30	25	27	30		

Other apertures on request.

* Missing part numbers issued on request.

Trellex LS-S PU side modules

LS-S-190-500-FR-PU (applied on** CVB2050/2060)

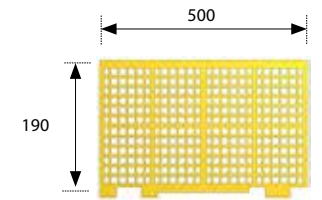

Hole type	Side Module Width (mm)	Thickness screen area (mm)	Min web thickness with flow (mm)	Min web thickness cross flow (mm)	Build height (mm)	Part No. 75/90 (Sh-A) *	Part No. 75/80 (Sh-A) *
FR2.5	190	6	3	3	30		
FR3	190	4	2.5	2.5	30	MM0392557	
FR3HD	190	6	3.5	3.5	30	6681535	
FR3.5	190	5	2.5	2.9	30	MM0384841	
FR4	190	5	2.6	2.6	30		
FR5	190	5	2.7	2.7	30	ZX11180739	
FR5HD	190	9	4	4	30		
FR5.5	190	7	3.5	3.5	30	MM0382202	
FR5.5HD	190	12	4	4	40		
FR6	190	6	3.4	3.4	30	MM0377232	
FR6HD	190	10	5	5	30		
FR6.5	190	6	3.5	3.5	30	ZX11203341	
FR6.5HD	190	14	4.5	4.5	40		
FR7	190	6	3.2	3.2	30	ZX11203344	
FR8	190	9	3.6	4.5	30	MM0383755	
FR9	190	9	4	5	30	MM0396716	
FR9HD	190	20	10	9	30		
FR10	190	10	5	5	30	6681604	
FR11	190	10	6	4.5	30	Non standard	6681621
FR12	190	12	6	6	30		MM0384839
FR13	190	12	5.2	8	30		ZX11203334
FR13HD	190	25	8.5	9.5	30		
FR14	190	15	8	8	30		6681589
FR15	190	15	7	7	30		ZX11180883
FR16	190	20	6.5	6.5	30		
FR17	190	20	8	9	30		ZX11203305
FR18	190	20	10	10	30		MM0377226
FR19	190	20	9.5	9.5	30		6681534
FR20	190	20	8.5	8.5	30	6681619	
FR21	190	20	11	11	30		
FR22	190	20	10	11	30		MM0385006
FR23	190	20	9.5	9.5	30		
FR24	190	25	12	12	30		MM0384840
FR25	190	25	11	11	30		6681596
FR26	190	25	10	12	30		
FR27	190	30	9	12	30		
FR28	190	30	15.5	15	30		6681648
FR36	190	25	17	17	40		
FR36	190	25	17	17	30		
FR44	190	30	25	27	30		

Other apertures on request.

* Missing part numbers issued on request.

** Screen type reference - valid for current screen design.

Trellex LS-S PU side modules

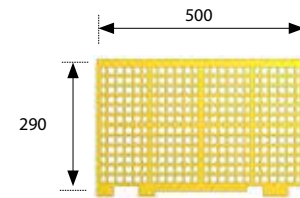

LS-S-290-500-FR-PU (applied on** CVB1540/1845/2050/2060)

Hole type	Side Module Width (mm)	Thickness screen area (mm)	Min web thickness with flow (mm)	Min web thickness cross flow (mm)	Build height (mm)	Part No. 75/90 (Sh-A) *	Part No. 75/80 (Sh-A) *
FR2.5	290	6	3	3	30		
FR3	290	4	2.5	2.5	30	ZX11165836	
FR3HD	290	6	3.5	3.5	30		
FR3.5	290	5	2.5	2.9	30	MM0384842	
FR4	290	5	2.6	2.6	30	6681157	
FR5	290	5	2.7	2.7	30	6681553	
FR5HD	290	9	4	4	30		
FR5.5	290	7	3.5	3.5	30	ZX11185460	
FR5.SHD	290	12	4	4	40		
FR6	290	6	3.4	3.4	30	6681221	
FR6HD	290	10	5	5	30		
FR6.5	290	6	3.5	3.5	30	ZX11203343	
FR6.SHD	290	14	4.5	4.5	40		
FR7	290	6	3.2	3.2	30	ZX11203345	
FR8	290	9	3.6	4.5	30		
FR9	290	9	4	5	30	6681512	6681409.80
FR9HD	290	20	10	9	30		
FR10	290	10	5	5	30	6680799	6681408.80
FR11	290	10	6	4.5	30		6681055
FR12	290	12	6	6	30		6681271
FR13	290	12	5.2	8	30		ZX11203340
FR13HD	290	25	8.5	9.5	30		
FR14	290	15	8	8	30		6681162
FR15	290	15	7	7	30		6681272
FR16	290	20	6.5	6.5	30		ZX11165835
FR17	290	20	8	9	30		ZX11170496
FR18	290	20	10	10	30		6681209
FR19	290	20	9.5	9.5	30		6680798
FR20	290	20	8.5	8.5	30		6681208
FR21	290	20	11	11	30		MM0392379
FR22	290	20	10	11	30		MM0392378
FR23	290	20	9.5	9.5	30		6681155
FR24	290	25	12	12	30		6681168
FR25	290	25	11	11	30		6680797
FR26	290	25	10	12	30		6680816
FR27	290	30	9	12	30		6680938
FR28	290	30	15.5	15	30		6680937
FR36	290	25	17	17	40		
FR36	290	25	17	17	30		MM0392376
FR44	290	30	25	27	30		MM0392374

Other apertures on request.

* Missing part numbers issued on request.

** Screen type reference - valid for current screen design.

Trellex LS-S PU side modules

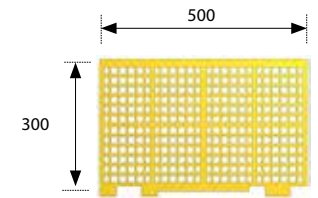

LS-S-300-500-FR-PU (applied on** TS2.X/3.X/4.X/5.X/6.X)

Hole type	Side Module Width (mm)	Thickness screen area (mm)	Min web thickness with flow (mm)	Min web thickness cross flow (mm)	Build height (mm)	Part No. 75/90 (Sh-A) *	Part No. 75/80 (Sh-A) *
FR2.5	300	6	3	3	30	MM0364211	
FR3	300	4	2.5	2.5	30	6680911	6681057
FR3HD	300	6	3.5	3.5	30	MM0367466	MM0411823
FR3.5	300	5	2.5	2.9	30	6680780	6680640.78
FR4	300	5	2.6	2.6	30	6680554	6680554.78
FR5	300	5	2.7	2.7	30	6680549	
FR5HD	300	9	4	4	30		
FR5.5	300	7	3.5	3.5	30	6680560	
FR5.SHD	300	12	4	4	40		
FR6	300	6	3.4	3.4	30	6680104	6680104.78
FR6HD	300	10	5	5	30	6680896	
FR6.5	300	6	3.5	3.5	30	6681000	6681000.78
FR6.SHD	300	14	4.5	4.5	40		
FR7	300	6	3.2	3.2	30	6680334	6680334.78
FR8	300	9	3.6	4.5	30	6680922	6680922.78
FR9	300	9	4	5	30	6680642	6680642.78
FR9HD	300	20	10	9	30	6681167.90	6681167
FR10	300	10	5	5	30	6680556	6680556.78
FR11	300	10	6	4.5	30		6680800
FR12	300	12	6	6	30		6681142
FR13	300	12	5.2	8	30		6680811
FR13HD	300	25	8.5	9.5	30		MM0421584
FR14	300	15	8	8	30		6680921
FR15	300	15	7	7	30		6681615
FR16	300	20	6.5	6.5	30		6680392
FR17	300	20	8	9	30		6680394
FR18	300	20	10	10	30		6680867
FR19	300	20	9.5	9.5	30		6680865
FR20	300	20	8.5	8.5	30		6680558
FR21	300	20	11	11	30		MM0421391
FR22	300	20	10	11	30		6680975
FR23	300	20	9.5	9.5	30		6680803
FR24	300	25	12	12	30		6680387
FR25	300	25	11	11	30		6680146
FR26	300	25	10	12	30		6681165
FR27	300	30	9	12	30		6680857
FR28	300	30	15.5	15	30		6680860
FR36	300	25	17	17	40		6680890
FR36	300	25	17	17	30		6680102
FR44	300	30	25	27	30		MM0343478

Other apertures on request.

* Missing part numbers issued on request.

** Screen type reference - valid for current screen design.

Trellex LS-S PU side modules

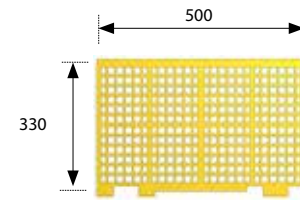

LS-S-330-500-FR-PU

Hole type	Side Module Width (mm)	Thickness screen area (mm)	Min web thickness with flow (mm)	Min web thickness cross flow (mm)	Build height (mm)	Part No. 75/90 (Sh-A) *	Part No. 75/80 (Sh-A) *
FR2.5	330	6	3	3	30		
FR3	330	4	2.5	2.5	30	6680659	
FR3HD	330	6	3.5	3.5	30		
FR3.5	330	5	2.5	2.9	30	6680726	
FR4	330	5	2.6	2.6	30	6680727	6680718
FR5	330	5	2.7	2.7	30	6680728	6680728.80
FR5HD	330	9	4	4	30	ZX11277483	
FR5.5	330	7	3.5	3.5	30	6680729	6680729.80
FR5.5HD	330	12	4	4	40		
FR6	330	6	3.4	3.4	30	6680335	
FR6HD	330	10	5	5	30		
FR6.5	330	6	3.5	3.5	30		
FR6.5HD	330	14	4.5	4.5	40		
FR7	330	6	3.2	3.2	30	6680117	6680117.78
FR8	330	9	3.6	4.5	30	6680730	6680714
FR9	330	9	4	5	30	6680657	
FR9HD	330	20	10	9	30		
FR10	330	10	5	5	30	6680428	6680428.78
FR11	330	10	6	4.5	30	Non standard	6680731
FR12	330	12	6	6	30		6680732
FR13	330	12	5.2	8	30		6680733
FR13HD	330	25	8.5	9.5	30		
FR14	330	15	8	8	30		6680734
FR15	330	15	7	7	30		6680384
FR16	330	20	6.5	6.5	30		6680735
FR17	330	20	8	9	30		6680917
FR18	330	20	10	10	30		6680736
FR19	330	20	9.5	9.5	30		6680429
FR20	330	20	8.5	8.5	30		6680737
FR21	330	20	11	11	30		6680738
FR22	330	20	10	11	30		6680739
FR23	330	20	9.5	9.5	30		6680373
FR24	330	25	12	12	30		6680740
FR25	330	25	11	11	30		6680300
FR26	330	25	10	12	30		6680813
FR27	330	30	9	12	30		
FR28	330	30	15.5	15	30		MM0365021
FR36	330	25	17	17	40		6680773
FR36	330	25	17	17	30		6680124
FR44	330	30	25	27	30		6681309

Other apertures on request.

* Missing part numbers issued on request.

Trellex LS-S PU side modules

Trellex LS-S-500

Machined/PU-cast from standard modules (SLS/STS)

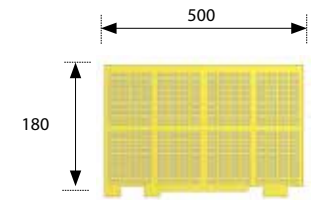

LS-S-180-500-SLS/STS-PU

Hole type	Side Module Width (mm)	Thickness screen area (mm)	Min web thickness with flow (mm)	Min web thickness cross flow (mm)	Build height (mm)	Part No. 75/90 (Sh-A) *	Part No. 75/80 (Sh-A) *
SLS 0.63x12	180	8	4	3	30		
SLS 0.8x12	180	8	5.5	3.3	30		
SLS 1x13	180	6	3.5	3	30		
SLS 1x17	180	15	5	3.8	30		
SLS 1.4x20	180	14	3.1	3.1	30		
SLS 1.5x12	180	7	5.5	3.5	30		
SLS 1.6x19	180	15	3.45	4.1	30		
SLS 1.6x20	180	8	2.9	2.9	30		
SLS 2x12	180	8	5.5	3.5	30		
SLS 2.5x12	180	10	5.5	4	30		
SLS 3x22	180	16	4	6	30		
SLS 4x15	180	12	7	4	30		
SLS 4x22	180	16	4	6	30		
SLS 5x15	180	12	7	4	30		
SLS 5x26	180	20	13.5	5.7	30		
SLS 6x20HD	180	20	8	6	30		
SLS 7x32	180	20	6	6	30		
SLS 8x27,5	180	30	8,3	10	40		
SLS 9x13	180	12	4.8	4.8	30		
SLS 10x22	180	20	6	6	30		
SLS 12x27,5	180	30	10	10	40		
STS 0.63x12	180	8	3.5	3.5	30		
STS 0.8x12	180	8	3	6	30		
STS 1x12HD	180	10	5	5	40		
STS 1.5x12	180	7	3	5	30		
STS 2x12	180	8	5	6	30		
STS 2.5x12	180	20	5.5	5.5	30		
STS 2.5x25HD	180	30	10	10	40		
STS 3x12HD	180	20	5.5	8	30		
STS 3x20	180	15	8	5	40		
STS 4x15	180	6	3	6	30		
STS 4x15 "HD"	180	20	5.5	5.5	30		
STS 5x25	180	20	8	6	30		
STS 8x25	180	20	6.5	6.5	40		
STS 10x40	180	30	10	9,5	40		
STS 11x25	180	30	7	8	30		

Other apertures on request.

SLS = With flow, STS = Cross flow

* Missing part numbers issued on request.

Trellex LS-S PU side modules

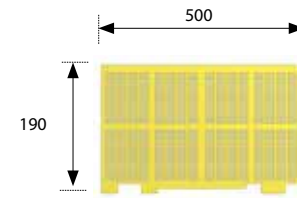

LS-S-190-500-SLS/STS-PU (applied on** CVB2050/2060)

Hole type	Side Module Width (mm)	Thickness screen area (mm)	Min web thickness with flow (mm)	Min web thickness cross flow (mm)	Build height (mm)	Part No. 75/90 (Sh-A) *	Part No. 75/80 (Sh-A) *
SLS 0.63x12	190	8	4	3	30	MM0384392	
SLS 0.8x12	190	8	5.5	3.3	30		
SLS 1x13	190	6	3.5	3	30		
SLS 1x17	190	15	5	3.8	30	ZX11323154	
SLS 1.4x20	190	14	3.1	3.1	30		
SLS 1.5x12	190	7	5.5	3.5	30		
SLS 1.6x19	190	15	3.45	4.1	30		
SLS 1.6x20	190	8	2.9	2.9	30		
SLS 2x12	190	8	5.5	3.5	30		
SLS 2.5x12	190	10	5.5	4	30		
SLS 3x22	190	16	4	6	30		
SLS 4x15	190	12	7	4	30		
SLS 4x22	190	16	4	6	30		
SLS 5x15	190	12	7	4	30		
SLS 5x26	190	20	13.5	5.7	30		
SLS 6x20HD	190	20	8	6	30		
SLS 7x32	190	20	6	6	30		
SLS8x27,5	190	30	8,3	10	40		
SLS 9x13	190	12	4.8	4.8	30		
SLS 10x22	190	20	6	6	30		
SLS 12x27.5	190	30	10	10	40		
STS 0.63x12	190	8	3.5	3.5	30	ZX11253765	
STS 0.8x12	190	8	3	6	30		
STS 1x12HD	190	10	5	5	40		
STS 1.5x12	190	7	3	5	30		
STS 2x12	190	8	5	6	30		
STS 2.5x12	190	20	5.5	5.5	30		
STS 2.5x25HD	190	30	10	10	40		
STS 3x12HD	190	20	5.5	8	30		
STS 3x20	190	15	8	5	40		
STS 4x15	190	6	3	6	30		
STS 4x15	190	20	5.5	5.5	30		
STS 5x25	190	20	8	6	30		
STS 8x25	190	20	6.5	6.5	40		
STS 10x40	190	30	10	9.5	40		
STS 11x25	190	30	7	8	30		

Other apertures on request.

SLS = With flow, STS = Cross flow

* Missing part numbers issued on request.

** Screen type reference - valid for current screen design.

Trellex LS-S PU side modules

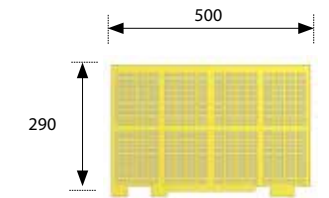

LS-S-290-500-SLS/STS-PU (applied on** CVB1540/1845/2050/2060)

Hole type	Side Module Width (mm)	Thickness screen area (mm)	Min web thickness with flow (mm)	Min web thickness cross flow (mm)	Build height (mm)	Part No. 75/90 (Sh-A) *	Part No. 75/80 (Sh-A) *
SLS 0.63x12	290	8	4	3	30	MM0379664	
SLS 0.8x12	290	8	5.5	3.3	30	MM0393389	
SLS 1x13	290	6	3.5	3	30	6681111	MM0393562
SLS 1x17	290	15	5	3.8	30	MM0393390	
SLS 1.4x20	290	14	3.1	3.1	30	MM0393560	
SLS 1.5x12	290	7	5.5	3.5	30	MM0393561	
SLS 1.6x19	290	15	3.45	4.1	30	MM0393564	
SLS 1.6x20	290	8	2.9	2.9	30	MM0393565	
SLS 2x12	290	8	5.5	3.5	30	MM0393567	
SLS 2.5x12	290	10	5.5	4	30	MM0393391	
SLS 3x22	290	16	4	6	30	MM0393392	
SLS 4x15	290	12	7	4	30	MM0393568	
SLS 4x22	290	16	4	6	30	MM0393570	
SLS 5x15	290	12	7	4	30		MM0393571
SLS 5x26	290	20	13.5	5.7	30		MM0393572
SLS 6x20HD	290	20	8	6	30		
SLS 7x32	290	20	6	6	30		MM0393573
SLS 8x27.5	290	30	8.3	10	40		
SLS 9x13	290	12	4.8	4.8	30		MM0393575
SLS 10x22	290	20	6	6	30		MM0393576
SLS 12x27.5	290	30	10	10	40		
STS 0.63x12	290	8	3.5	3.5	30	MM0393578	
STS 0.8x12	290	8	3	6	30	6681108	
STS 1x12HD	290	10	5	5	40	6681282	
STS 1.5x12	290	7	3	5	30	ZX11202807	6681411.80
STS 2x12	290	8	5	6	30	MM0393579	
STS 2.5x12	290	20	5.5	5.5	30		6681100
STS 2.5x25HD	290	30	10	10	40		
STS 3x12HD	290	20	5.5	8	30		
STS 3x20	290	15	8	5	40		
STS 4x15	290	6	3	6	30	MM0393580	
STS 4x15	290	20	5.5	5.5	30		6681304
STS 5x25	290	20	8	6	30		6681097
STS 8x25	290	20	6.5	6.5	40		
STS 10x40	290	30	10	9.5	40		
STS 11x25	290	30	7	8	30		MM0393581

Other apertures on request.

SLS = With flow, STS = Cross flow

* Missing part numbers issued on request.

** Screen type reference - valid for current screen design.

Trellex LS-S PU side modules

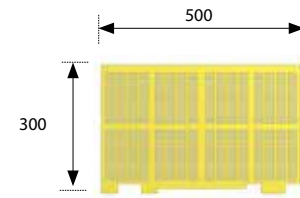

LS-S-300-500-SLS/STS-PU (applied on** TS2.X/3.X/4.X/5.X/6.X)

Hole type	Side Module Width (mm)	Thickness screen area (mm)	Min web thickness with flow (mm)	Min web thickness cross flow (mm)	Build height (mm)	Part No. 75/90 (Sh-A) *	Part No. 75/80 (Sh-A) *
SLS 0.63x12	300	8	4	3	30		
SLS 0.8x12	300	8	5.5	3.3	30		6681480
SLS 1x13	300	6	3.5	3	30	6680881	6681115
SLS 1x17	300	15	5	3.8	30		
SLS 1.4x20	300	14	3.1	3.1	30		
SLS 1.5x12	300	7	5.5	3.5	30	6681529	
SLS 1.6x19	300	15	3.45	4.1	30		
SLS 1.6x20	300	8	2.9	2.9	30		MM0345474
SLS 2x12	300	8	5.5	3.5	30		6681617
SLS 2.5x12	300	10	5.5	4	30		ZX11156539
SLS 3x22	300	16	4	6	30		MM0345174
SLS 4x15	300	12	7	4	30		MM0359642
SLS 4x22	300	16	4	6	30		MM0345175
SLS 5x15	300	12	7	4	30		6681348
SLS 5x26	300	20	13.5	5.7	30		
SLS 6x20HD	300	20	8	6	30		
SLS 7x32	300	20	6	6	30		
SLS 8x27.5	300	30	8.3	10	40		
SLS 9x13	300	12	4.8	4.8	30		6680932
SLS 10x22	300	20	6	6	30		6681650
SLS 12x27.5	300	30	10	10	40		
STS 0.63x12	300	8	3.5	3.5	30		
STS 0.8x12	300	8	3	6	30	6680787	6681091
STS 1x12HD	300	10	5	5	40	6680788	
STS 1.5x12	300	7	3	5	30	6680585	6680585-78
STS 2x12	300	8	5	6	30	6681305	
STS 2.5x12	300	20	5.5	5.5	30		6681130
STS 2.5x25HD	300	30	10	10	40		
STS 3x20	300	15	8	5	40		
STS 3x12HD	300	20	5.5	8	30		6680720
STS 4x15	300	6	3	6	30		
STS 4x15	300	20	5.5	5.5	30		
STS 5x25	300	20	8	6	30		6681113
STS 8x25	300	20	6.5	6.5	40		6680973
STS 10x40	300	30	10	9.5	40		
STS 11x25	300	30	7	8	30		

Other apertures on request.

SLS = With flow, STS = Cross flow

* Missing part numbers issued on request.

** Screen type reference - valid for current screen design.

Trellex LS-S PU side modules

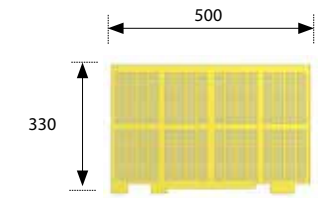

LS-S-330-500-SLS/STS-PU

Hole type	Side Module Width (mm)	Thickness screen area (mm)	Min web thickness with flow (mm)	Min web thickness cross flow (mm)	Build height (mm)	Part No. 75/90 (Sh-A) *	Part No. 75/80 (Sh-A) *
SLS 0.63x12	330	8	4	3	30	6670681	
SLS 0.8x12	330	8	5.5	3.3	30		
SLS 1x13	330	6	3.5	3	30		
SLS 1x17	330	15	5	3.8	30		
SLS 1.4x20	330	14	3.1	3.1	30		
SLS 1.5x12	330	7	5.5	3.5	30		
SLS 1.6x19	330	15	3.45	4.1	30		
SLS 1.6x20	330	8	2.9	2.9	30		
SLS 2x12	330	8	5.5	3.5	30		MM0375083
SLS 2.5x12	330	10	5.5	4	30		6681333
SLS 3x22	330	16	4	6	30		
SLS 4x15	330	12	7	4	30		
SLS 4x22	330	16	4	6	30		
SLS 5x15	330	12	7	4	30		
SLS 5x26	330	20	13.5	5.7	30		
SLS 6x20HD	330	20	8	6	30		
SLS 7x32	330	20	6	6	30		
SLS 8x27.5	330	30	8.3	10	40		
SLS 9x13	330	12	4.8	4.8	30		
SLS 10x22	330	20	6	6	30		
SLS 12x27.5	330	30	10	10	40		
STS 0.63x12	330	8	3.5	3.5	30		
STS 0.8x12	330	8	3	6	30		MM0365020
STS 1x12HD	330	10	5	5	40		6680771
STS 1.5x12	330	7	3	5	30		6680741 6680585-330.78
STS 2x12	330	8	5	6	30		
STS 2.5x12	330	20	5.5	5.5	30		
STS 2.5x25HD	330	30	10	10	40		
STS 3x12HD	330	20	5.5	8	30		6680968
STS 3x20	330	15	8	5	40		
STS 4x15	330	6	3	6	30		6680778
STS 4x15	330	20	5.5	5.5	30		6681361
STS 5x25	330	20	8	6	30		6681034
STS 8x25	330	20	6.5	6.5	40		
STS 10x40	330	30	10	9.5	40		
STS 11x25	330	30	7	8	30		

Other apertures on request.

SLS = With flow, STS = Cross flow

* Missing part numbers issued on request.

Trellex LS-S PU side modules

Trellex LS-S-610

Machined/PU-cast from standard modules (FR)

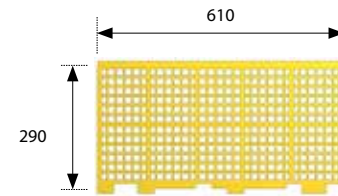

LS-S-290-610-FR-PU (applied on** CVB2661)

Hole type	Side Module Width (mm)	Thickness screen area (mm)	Min web thickness with flow (mm)	Min web thickness cross flow (mm)	Build height (mm)	Part No. 75/90 (Sh-D/Sh-A) *	Part No. 75/80 (Sh-D/Sh-A) *
FR2.5	290	6	3	3	30		MM0374464
FR3	290	4	2.5	2.5	30		
FR3HD	290	6	3.5	3.5	30		
FR3.5	290	5	2.5	2.9	30		
FR4	290	5	2.6	2.6	30	6681461	
FR5	290	5	2.7	2.7	30		
FR5HD	290	9	4	4	30		
FR5.5	290	7	3.5	3.5	30		
FR5.5HD	290	12	4	4	40		
FR6	290	6	3.4	3.4	30		
FR6HD	290	10	5	5	30		
FR6.5	290	6	3.5	3.5	30		
FR6.5HD	290	14	4.5	4.5	40		
FR7	290	6	3.2	3.2	30	6681460	
FR8	290	9	3.6	4.5	30	6681220	
FR9	290	9	4	5	30	6681205	
FR9HD	290	20	10	9	30		
FR10	290	10	5	5	30	ZX11257014	
FR11	290	10	6	4.5	30		6681458
FR12	290	12	6	6	30		6681459
FR13	290	12	5.2	8	30		6681445
FR13HD	290	25	8.5	9.5	30		
FR14	290	15	8	8	30		6681218
FR15	290	15	7	7	30		6681273
FR16	290	20	6.5	6.5	30		6681203
FR17	290	20	8	9	30		
FR18	290	20	10	10	30		6681201
FR19	290	20	9.5	9.5	30		ZX11201596
FR20	290	20	8.5	8.5	30		
FR21	290	20	11	11	30		
FR22	290	20	11	10	30		
FR23	290	20	9.5	9.5	30		
FR24	290	25	12	12	30		
FR25	290	25	14	11	30		
FR26	290	25	10	12	30		
FR27	290	30	13	9	30		
FR28	290	30	15.5	14	30		6681197
FR32	290	25	17	12	40		
FR37	290	30	17.5	16.5	40		

Other apertures on request.

* Missing part numbers issued on request.

** Screen type reference - valid for current screen design.

Trellex LS-S PU side modules

LS-S-300-610-FR-PU (applied on** TS2.X/5.X/6.X, LH, RF, MF)

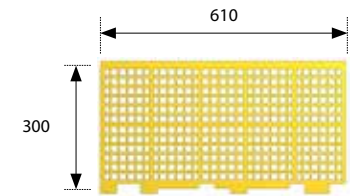

Hole type	Side Module Width (mm)	Thickness screen area (mm)	Min web thickness with flow (mm)	Min web thickness cross flow (mm)	Build height (mm)	Part No. 75/90 (Sh-D/Sh-A) *	Part No. 75/80 (Sh-D/Sh-A) *
FR2.5	300	6	3	3	30		
FR3	300	4	2.5	2.5	30	6680990	ZX11208629
FR3HD	300	6	3.5	3.5	30		
FR3.5	300	5	2.5	2.9	30	6680475	
FR4	300	5	2.6	2.6	30	6680565	
FR5	300	5	2.7	2.7	30	6680476	
FR5HD	300	9	4	4	30	6680572	
FR5.5	300	7	3.5	3.5	30	6680872	
FR5.5HD	300	12	4	4	40		
FR6	300	6	3.4	3.4	30	6680562	6680562.78
FR6HD	300	10	5	5	30	6681132	
FR6.5	300	6	3.5	3.5	30	6680477	
FR6.5HD	300	14	4.5	4.5	40		
FR7	300	6	3.2	3.2	30	6681004	
FR8	300	9	3.6	4.5	30	6680478	6680478.78
FR9	300	9	4	5	30	6680807	
FR9HD	300	20	10	9	30		
FR10	300	10	5	5	30	6680479	
FR11	300	10	6	4.5	30		6680551
FR12	300	12	6	6	30		6680581
FR13	300	12	5.2	8	30		ZX11179849
FR13HD	300	25	8.5	9.5	30		6681614
FR14	300	15	8	8	30		6680877
FR15	300	15	7	7	30		MM0359606
FR16	300	20	6.5	6.5	30		6680389
FR17	300	20	8	9	30		6680390
FR18	300	20	10	10	30		6680866
FR19	300	20	9.5	9.5	30		6680864
FR20	300	20	8.5	8.5	30		6680481
FR21	300	20	11	11	30		MM0421390
FR22	300	20	11	10	30		6680879
FR23	300	20	9.5	9.5	30		MM0409755
FR24	300	25	12	12	30		6680386
FR25	300	25	14	11	30		6680482
FR26	300	25	10	12	30		6681447
FR27	300	30	13	9	30		6680626
FR28	300	30	15.5	14	30		6680861
FR32	300	25	17	12	40		6680485
FR37	300	30	17.5	16.5	40		6681095

Other apertures on request.

* Missing part numbers issued on request.

** Screen type reference - valid for current screen design.

Trellex LS-S PU side modules

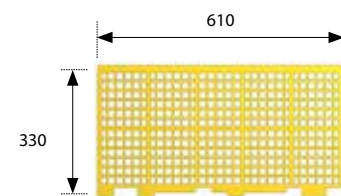

LS-S-330-610-FR-PU

Hole type	Side Module Width (mm)	Thickness screen area (mm)	Min web thickness with flow (mm)	Min web thickness cross flow (mm)	Build height (mm)	Part No. 75/90 (Sh-D/Sh-A) *	Part No. 75/80 (Sh-D/Sh-A) *
FR2.5	330	6	3	3	30		
FR3	330	4	2.5	2.5	30	6680742	
FR3HD	330	6	3.5	3.5	30		
FR3.5	330	5	2.5	2.9	30	6680743	
FR4	330	5	2.6	2.6	30	6680744	
FR5	330	5	2.7	2.7	30	6680745	
FR5HD	330	9	4	4	30		
FR5.5	330	7	3.5	3.5	30	6680981	
FR5.5HD	330	12	4	4	40		
FR6	330	6	3.4	3.4	30	6680746	
FR6HD	330	10	5	5	30		
FR6.5	330	6	3.5	3.5	30	6680747	
FR6.5HD	330	14	4.5	4.5	40		
FR7	330	6	3.2	3.2	30		6680748
FR8	330	9	3.6	4.5	30	6680749	
FR9	330	9	4	5	30		6680750
FR9HD	330	20	10	9	30		
FR10	330	10	5	5	30	6680751	
FR11	330	10	6	4.5	30		6680752
FR12	330	12	6	6	30		6680753
FR13	330	12	5.2	8	30		6680754
FR13HD	330	25	8.5	9.5	30		
FR14	330	15	8	8	30		6680755
FR15	330	15	7	7	30		6680385
FR16	330	20	6.5	6.5	30		6680756
FR17	330	20	8	9	30		6680757
FR18	330	20	10	10	30		6681171
FR19	330	20	9.5	9.5	30		6680758
FR20	330	20	8.5	8.5	30		6680759
FR21	330	20	11	11	30		
FR22	330	20	11	10	30		6680760
FR23	330	20	9.5	9.5	30		6680761
FR24	330	25	12	12	30		6680762
FR25	330	25	14	11	30		6680763
FR26	330	25	10	12	30		
FR27	330	30	13	9	30		6681170
FR28	330	30	15.5	14	30		MM0406034
FR32	330	25	17	12	40		6680764
FR37	330	30	17.5	16.5	40		

Non standard

Other apertures on request.

* Missing part numbers issued on request.

Maximum capacity and accuracy with minimal downtime

Trellex LS-S PU side modules

Trellex LS-S-610

Machined/PU-cast from standard modules (SLS/STS)

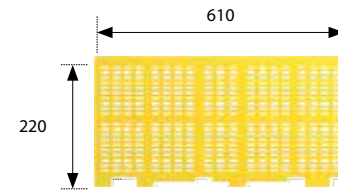

LS-S-220-610-SLS/STS-PU (applied on** CVB2661)

Hole type	Side Module Width (mm)	Thickness screen area (mm)	Min web thickness with flow (mm)	Min web thickness cross flow (mm)	Build height (mm)	Part No. 75/90 (Sh-D/Sh-A) *	Part No. 75/80 (Sh-D/Sh-A) *
SLS 0.63x12	220	8	4	3	30		
SLS 0.8x12	220	8	5.5	3.3	30		
SLS 1x13	220	6	3.5	3	30		
SLS 1x17	220	15	5	3.8	30		
SLS 1.4x20	220	14	3.1	3.1	30		
SLS 1.5x12	220	7	5.5	3.5	30		
SLS 1.6x19	220	15	3.45	4.1	30		
SLS 1.6x20	220	8	2.9	2.9	30	MM0409757	
SLS 2x12	220	8	5.5	3.5	30		
SLS 2.5x12	220	10	5.5	4	30		
SLS 3x22	220	20	4	6	30		
SLS 4x15	220	12	7	4	30		
SLS 4x22	220	16	4	6	30		
SLS 5x15	220	12	7	4	30		
SLS 5x26	220	20	13.5	5.7	30		
SLS 6x20HD	220	20	8	6	30		
SLS 7x32	220	20	6	6	30		
SLS 8x27,5	220	30	8,3	10	40		
SLS 8x27.5	220	30	8.3	10	40		
SLS 8x56	220	20	6.4	19.5	30		
SLS 9x13	220	12	4.8	4.8	30		
SLS 10x22	220	20	6	6	30		
SLS 12x25	220	20	10	14	30		
SLS 12x27.5	220	30	10	10	40		
SLS 12x50	220	20	16	10	30		
SLS 14x25	220	15	14	7.7	30		
SLS 16.7x25	220	30	10	9	40		
SLS 19x51.5	220	30	9	10	40		
SLS 25x48	220	30	17	14	40		
SLS 26x32	220	30	10	17	40		
SLS 30x58	220	30	15	15	40		
SLS 37x57	220	40	17.5	18	40		
SLS 37x112	220	40	35.7	33.5	40		
STS 0.3x11	220	8	2.9	2.45	40		
STS 0.5x11	220	8	2.9	2.45	40		
STS 0.63x11	220	8	2.9	2.45	40		
STS 0.8x11	220	8	2.9	2.5	40		
STS 0.63x12	220	8	3.5	3.5	30		
STS 0.8x12	220	8	3	6	30		
STS 1x12HD	220	10	5	5	40		

Continued from previous page

LS-S-220-610-SLS/STS-PU (applied on** CVB2661)

Hole type	Side Module Width (mm)	Thickness screen area (mm)	Min web thickness with flow (mm)	Min web thickness cross flow (mm)	Build height (mm)	Part No. 75/90 (Sh-D/Sh-A) *	Part No. 75/80 (Sh-D/Sh-A) *
STS 1.5x12	220	7	3	5	30		
STS 2x12	220	8	5	7	30		
STS 2.5x12	220	20	5.5	5.5	30		
STS 2.5x25HD	220	30	10	10	40		
STS 3x12HD	220	20	5.5	8	30		
STS 3x20	220	15	5,5	8	40		
STS 4x15	220	6	3	6	30		
STS 4x15	220	20	5.5	5.5	30		
STS 5x25	220	20	8	6	30		
STS 8x25	220	20	6.5	6.5	40		
STS 10x40	220	30	10	9,5	40		
STS 11x25	220	30	7	8	30		

Other apertures on request.
 SLS = With flow, STS = Cross flow
 * Missing part numbers issued on request.
 ** Screen type reference - valid for current screen design.



Trellex LS-S PU side modules

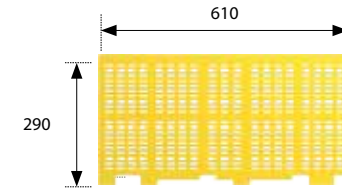

LS-S-290-610-SLS/STS-PU (applied on** CVB2661)

Hole type	Side Module Width (mm)	Thickness screen area (mm)	Min web thickness with flow (mm)	Min web thickness cross flow (mm)	Build height (mm)	Part No. 75/90 (Sh-D/Sh-A) *	Part No. 75/80 (Sh-D/Sh-A) *
SLS 0.63x12	290	8	4	3	30		
SLS 0.8x12	290	8	5.5	3.3	30		
SLS 1x13	290	6	3.5	3	30		
SLS 1x17	290	15	5	3.8	30		
SLS 1.4x20	290	14	3.1	3.1	30		
SLS 1.5x12	290	7	5.5	3.5	30	MM0393802	
SLS 1.6x19	290	15	3.45	4.1	30		
SLS 1.6x20	290	8	2.9	2.9	30		
SLS 2x12	290	8	5.5	3.5	30		
SLS 2.5x12	290	10	5.5	4	30		ZX11159331
SLS 3x22	290	20	4	6	30		
SLS 4x15	290	12	7	4	30		
SLS 4x22	290	16	4	6	30		
SLS 5x15	290	12	7	4	30		
SLS 5x26	290	20	13.5	5.7	30		
SLS 6x20HD	290	20	8	6	30	ZX11157662	
SLS 7x32	290	20	6	6	30		
SLS 8x27.5	290	30	8.3	10	40		
SLS 8x56	290	20	6.4	19.5	30		
SLS 9x13	290	12	4.8	4.8	30		
SLS 10x22	290	20	6	6	30		
SLS 12x25	290	20	10	14	30		
SLS 12x27.5	290	30	10	10	40		
SLS 12x50	290	20	16	10	30		
SLS 14x25	290	15	14	7.7	30		
SLS 16.7x25	290	30	10	9	40		
SLS 19x51.5	290	30	9	10	40		
SLS 25x48	290	30	17	14	40		
SLS 26x32	290	30	10	17	40		MM0374522
SLS 30x58	290	30	15	15	40		
SLS 37x57	290	40	17.5	18	40		
SLS 37x112	290	40	35.7	33.5	40		
STS 0.3x11	290	8	2.9	2.45	40		
STS 0.5x11	290	8	2.9	2.45	40		
STS 0.63x11	290	8	2.9	2.45	40		
STS 0.8x11	290	8	2.9	2.5	40		
STS 0.63x12	290	8	3.5	3.5	30		
STS 0.8x12	290	8	3	6	30	MM0371385	
STS 1x12HD	290	10	5	5	40		

LS-S-290-610-SLS/STS-PU (applied on** CVB2661)

Hole type	Side Module Width (mm)	Thickness screen area (mm)	Min web thickness with flow (mm)	Min web thickness cross flow (mm)	Build height (mm)	Part No. 75/90 (Sh-D/Sh-A) *	Part No. 75/80 (Sh-D/Sh-A) *
STS 1.5x12	290	7	3	5	30		
STS 2x12	290	8	5	7	30	MM0371394	
STS 2.5x12	290	20	5.5	5.5	30		
STS 2.5x25HD	290	30	10	10	40		
STS 3x12HD	290	20	5.5	8	30		
STS 3x20	290	15	8	5	40		
STS 4x15	290	6	3	6	30	ZX11182228	
STS 4x15	290	20	5.5	5.5	30		
STS 5x25	290	20	8	6	30		
STS 8x25	290	20	6.5	6.5	40		
STS 10x40	290	30	10	9.5	40		
STS 11x25	290	30	7	8	30		

Other apertures on request.
 SLS = With flow, STS = Cross flow
 * Missing part numbers issued on request.
 ** Screen type reference - valid for current screen design.

Table continues on next page →

Trellex LS-S PU side modules

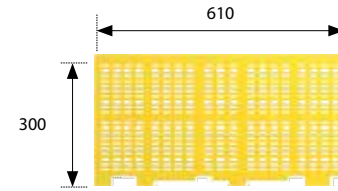

LS-S-300-610-SLS/STS-PU (applied on** TS2.X/5.X/6.X, LH, MF, RF)

Hole type	Side Module Width (mm)	Thickness screen area (mm)	Min web thickness with flow (mm)	Min web thickness cross flow (mm)	Build height (mm)	Part No. 75/90 (Sh-D/Sh-A) *	Part No. 75/80 (Sh-D/Sh-A) *
SLS 0.63x12	300	8	4	3	30	6680636	
SLS 0.8x12	300	8	5.5	3.3	30		
SLS 1x13	300	6	3.5	3	30	6680486	
SLS 1x17	300	15	5	3.8	30	MM0344458	
SLS 1.4x20	300	14	3.1	3.1	30		MM0369535
SLS 1.5x12	300	7	5.5	3.5	30	6680487	
SLS 1.6x19	300	15	3.45	4.1	30		
SLS 1.6x20	300	8	2.9	2.9	30		MM0345473
SLS 2x12	300	8	5.5	3.5	30	6680488	
SLS 2.5x12	300	10	5.5	4	30		MM0360019
SLS 3x22	300	20	4	6	30		MM0345168
SLS 4x15	300	12	7	4	30	6681060	
SLS 4x22	300	16	4	6	30		6681626
SLS 5x15	300	12	7	4	30		
SLS 5x26	300	20	13.5	5.7	30		
SLS 6x20HD	300	20	8	6	30	MM0376025	6680722.78
SLS 7x32	300	20	6	6	30		MM0349535
SLS 8x27.5	300	30	8.3	10	40		MM0378901
SLS 8x56	300	20	6.4	19.5	30		6681625
SLS 9x13	300	12	4.8	4.8	30	6681644	6680974
SLS 10x22	300	20	6	6	30	6681645.80	6681645
SLS 12x25	300	20	10	14	30		6681150.78
SLS 12x27.5	300	30	10	10	40		MM0367347
SLS 12x50	300	20	16	10	30		6681152.78
SLS 14x25	300	15	14	7.7	30		6681662
SLS 16.7x25	300	30	10	9	40		
SLS 19x51.5	300	30	9	10	40		6680650.78
SLS 25x48	300	30	17	14	40		6680928
SLS 26x32	300	30	10	17	40		
SLS 30x58	300	30	15	15	40		6680971
SLS 37x57	300	40	17.5	18	40		
SLS 37x112	300	40	35.7	33.5	40		
STS 0.63x12	300	8	3.5	3.5	30	6681210	
STS 0.8x12	300	8	3	6	30	6681206	
STS 1x12HD	300	10	5	5	40	MM0377030	
STS 1.5x12	300	7	3	5	30	MM0376193	
STS 2x12	300	8	5	7	30		
STS 2.5x12	300	20	5.5	5.5	30		6681026.78
STS 2.5x25HD	300	30	10	10	40		MM0370808

LS-S-300-610-SLS/STS-PU (applied on** TS2.X/5.X/6.X, LH, MF, RF)

Hole type	Side Module Width (mm)	Thickness screen area (mm)	Min web thickness with flow (mm)	Min web thickness cross flow (mm)	Build height (mm)	Part No. 75/90 (Sh-D/Sh-A) *	Part No. 75/80 (Sh-D/Sh-A) *
STS 3x12HD	300	20	5.5	8	30	6681019	
STS 3x20	300	15	8	5	40		
STS 4x15	300	6	3	6	30		
STS 4x15	300	20	5.5	5.5	30		
STS 5x25	300	20	8	6	30		MM0360484
STS 8x25	300	20	6.5	6.5	40		6681046
STS10x40	300	30	10	9.5	40		
STS 11x25	300	30	7	8	30		6681647

Other apertures on request.

SLS = With flow, STS = Cross flow

* Missing part numbers issued on request.

** Screen type reference - valid for current screen design.

Table continues on next page →

Trellex LS Wedge wire

Wedge wire LS-S modules

Stainless steel - side modules

Trellex LS-S 295-610

Slot Direction	Hole type (mm)	Relative Open Area (%)	Effective Open Area (%)	Build height (mm)	Part No.
With Flow	0.3	11.5	9.4	40	MM0371174
With Flow	0.5	17.9	14.6	40	MM0400075
With Flow	0.75	24.6	20.5	40	
With Flow	1.0	30.3	24.8	40	
With Flow	1.25	32.2	28.8	40	

Trellex LS-S 610-305 - Light Duty

Slot Direction	Hole type (mm)	Relative open area (%)	Effective open area (%)	Build height (mm)	Part No. *
With Flow	0.5LD	18	15	40	9260010400055
With Flow	0.75LD	25	21	40	9260010400056
With Flow	1.0LD	30	26	40	9260010400057
With Flow	1.25LD	35	30	40	9260010400058
With Flow	1.4LD	38	32	40	9260010400059
With Flow	1.25LD	35	30	40	9260010400061

Trellex LS-S 711-305 - light duty

Slot Direction	Hole type (mm)	Relative open area (%)	Effective open area (%)	Build height (mm)	Part No.
With Flow	0.5 LD	18	15	40	ZX11196267
With Flow	0.75 LD	25	21	40	ZX11196268
With Flow	1.0 LD	30	26	40	ZX11196269
With Flow	1.25 LD	35	30	40	ZX11196270
With Flow	1.4 LD	38	32	40	ZX11196271
With Flow	1.8 LD	44	37	40	ZX11196272

Trellex LS-S 610-305 - heavy duty

Slot Direction	Hole type (mm)	Relative open area (%)	Effective open area (%)	Build height (mm)	Part No. *
With Flow	0.5HD	14	12	40	9260010400050
With Flow	0.75HD	20	17	40	9260010400051
With Flow	1.0HD	25	21	40	9260010400052
With Flow	1.25HD	29	24	40	9260010400053
With Flow	1.4HD	31	26	40	9260010400054
With Flow	1.25 HD	29	24	40	9260010400038

Trellex LS-S 711LS-305 - heavy duty

Slot Direction	Hole type (mm)	Relative open area (%)	Effective open area (%)	Build height (mm)	Part No.
With Flow	0.5HD	14	12	40	ZX11193646
With Flow	0.75HD	20	17	40	ZX11196262
With Flow	1.0HD	25	21	40	ZX11196263
With Flow	1.25HD	29	24	40	ZX11196264
With Flow	1.4HD	31	26	40	ZX11196265
With Flow	1.8HD	37	31	40	ZX11196266



Trellex LS-S HiPer Flow PU side modules

Trellex LS-S-500

Machined/PU-cast from HiPer Flow modules

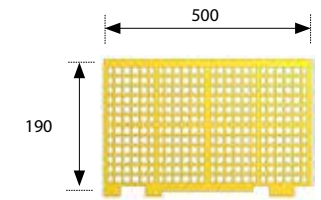

LS-S-190-500 (applied on** CVB2050/2060)

Hole type	Side Module Width (mm)	Thickness screen area (mm)	Min web thickness with flow (mm)	Min web thickness cross flow (mm)	Build height (mm)	Part No. 75/90 (Sh-D/Sh-A) *	Part No. 75/80 (Sh-D/Sh-A) *
FR3.5EX	190	4	2	2	30		6681594
FR5EX	190	5	2	2.2	30		6681590
FR6EX	190	6	2.4	2.4	30		6681592
FR7EX	190	7	2.8	3.2	30		
FR8EX	190	8	2.6	3.2	30		
FR9EX	190	9	3	3.5	30		6681622
FR10EX	190	10	3	4.2	30	Non standard	6681620
FR13EX	190	15	4.3	6	30		6681587
FR15EX	190	15	5	4.1	30		
FR16EX	190	20	6.2	4.9	30		MM0397069
FR18EX	190	20	6.25	9	30		MM0396976
FR22EX	190	20	7	7.5	30		
FR25EX	190	25	8.5	6.8	30		

Other apertures on request.

* Missing part numbers issued on request.

** Screen type reference - valid for current screen design.

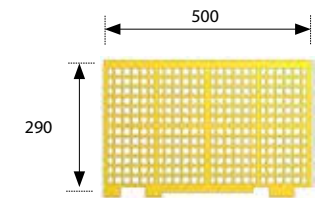

LS-S-290-500 (applied on** CVB1540/1845/2050/2060)

Hole type	Side Module Width (mm)	Thickness screen area (mm)	Min web thickness with flow (mm)	Min web thickness cross flow (mm)	Build height (mm)	Part No. 75/90 (Sh-D/Sh-A) *	Part No. 75/80 (Sh-D/Sh-A) *
FR3.5EX	290	4	2	2	30		6681595
FR5EX	290	5	2	2.2	30		6681591
FR6EX	290	6	2.4	2.4	30		6681593
FR7EX	290	7	2.8	3.2	30		MM0392594
FR8EX	290	8	2.6	3.2	30		6681601
FR9EX	290	9	3	3.5	30		6681603
FR10EX	290	10	3	4.2	30	Non standard	ZX11181097
FR13EX	290	15	4.3	6	30		6681588
FR15EX	290	15	5	4.1	30		MM0392598
FR16EX	290	20	6.2	4.9	30		MM0392604
FR18EX	290	20	6.25	9	30		MM0396985
FR22EX	290	20	7	7.5	30		MM0392606
FR25EX	290	25	8.5	6.8	30		

Other apertures on request.

* Missing part numbers issued on request.

** Screen type reference - valid for current screen design.

Trellex LS-S HiPer Flow PU side modules

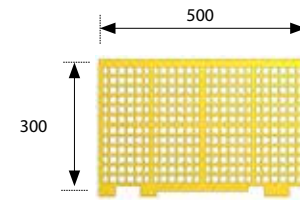

LS-S-300-500 (applied on** TS3.X/4.X/5.X/6.X)

Hole type	Side Module Width (mm)	Thickness screen area (mm)	Min web thickness with flow (mm)	Min web thickness cross flow (mm)	Build height (mm)	Part No. 75/90 (Sh-D/Sh-A) *	Part No. 75/80 (Sh-D/Sh-A) *
FR3.5EX	300	4	2	2	30		MM0359619
FR5EX	300	5	2	2.2	30	6681485	MM0359612
FR6EX	300	6	2.4	2.4	30	6681524	MM0359611
FR7EX	300	7	2.8	3.2	30	MM0365509	MM0365607
FR8EX	300	8	2.6	3.2	30		
FR9EX	300	9	3	3.5	30		MM0359617
FR10EX	300	10	3	4.2	30		MM0359615
FR13EX	300	15	4.3	6	30		MM0354667
FR15EX	300	15	5	4.1	30		MM0354075
FR16EX	300	20	6.2	4.9	30		MM0354073
FR18EX	300	20	6.25	9	30		6681598
FR22EX	300	20	7	7.5	30		MM0354071
FR25EX	300	25	8.5	6.8	30		MM0369554

Other apertures on request.

* Missing part numbers issued on request.

** Screen type reference - valid for current screen design.

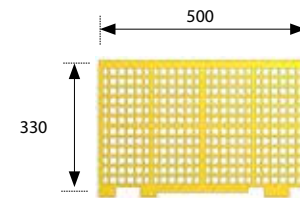

LS-S-330-500

Hole type	Side Module Width (mm)	Thickness screen area (mm)	Min web thickness with flow (mm)	Min web thickness cross flow (mm)	Build height (mm)	Part No. 75/90 (Sh-D/Sh-A) *	Part No. 75/80 (Sh-D/Sh-A) *
FR3.5EX	330	4	2	2	30		
FR5EX	330	5	2	2.2	30		
FR6EX	330	6	2.4	2.4	30		6681318
FR7EX	330	7	2.8	3.2	30		
FR8EX	330	8	2.6	3.2	30		
FR9EX	330	9	3	3.5	30		
FR10EX	330	10	3	4.2	30		6681315
FR13EX	330	15	4.3	6	30		
FR15EX	330	15	5	4.1	30		
FR16EX	330	20	6.2	4.9	30		
FR18EX	330	20	6.25	9	30		
FR22EX	330	20	7	7.5	30		
FR25EX	330	25	8.5	6.8	30		

Other apertures on request.

* Missing part numbers issued on request.

Trellex LS-S HiPer Flow PU side modules

Trellex LS-S-610

Machined/PU-cast from HiPer Flow modules

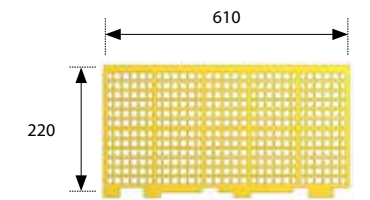

LS-S-220-610 (applied on** CVB2661)

Hole type	Side Module Width (mm)	Thickness screen area (mm)	Min web thickness with flow (mm)	Min web thickness cross flow (mm)	Build height (mm)	Part No. 75/90 (Sh-D/Sh-A) *	Part No. 75/80 (Sh-D/Sh-A) *
FR3.5EX	220	4	2	2	30		
FR5EX	220	5	2	2.2	30		
FR6EX	220	6	2.4	2.4	30		
FR7EX	220	7	2.8	3.2	30		
FR8EX	220	8	2.6	3.2	30		
FR9EX	220	9	3	3.5	30		
FR10EX	220	10	3	4.2	30		
FR13EX	220	15	4.3	6	30		
FR15EX	220	15	5	4.1	30		
FR16EX	220	20	6.2	4.9	30		
FR18EX	220	20	6.25	9	30		
FR22EX	220	20	7	7.5	30		
FR25EX	220	25	8.5	6.8	30		

Other apertures on request.

* Missing part numbers issued on request.

** Screen type reference - valid for current screen design.

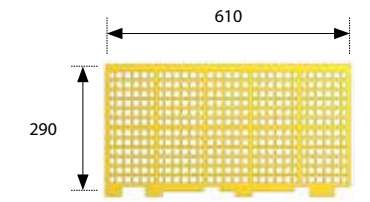

LS-S-290-610 (applied on** CVB2661)

Hole type	Side Module Width (mm)	Thickness screen area (mm)	Min web thickness with flow (mm)	Min web thickness cross flow (mm)	Build height (mm)	Part No. 75/90 (Sh-D/Sh-A) *	Part No. 75/80 (Sh-D/Sh-A) *
FR3.5EX	290	4	2	2	30		ZX11195528
FR5EX	290	5	2	2.2	30		
FR6EX	290	6	2.4	2.4	30		
FR7EX	290	7	2.8	3.2	30		
FR8EX	290	8	2.6	3.2	30		
FR9EX	290	9	3	3.5	30		
FR10EX	290	10	3	4.2	30		
FR13EX	290	15	4.3	6	30		
FR15EX	290	15	5	4.1	30		
FR16EX	290	20	6.2	4.9	30		
FR18EX	290	20	6.25	9	30		
FR22EX	290	20	7	7.5	30		
FR25EX	290	25	8.5	6.8	30		

Other apertures on request.

* Missing part numbers issued on request.

** Screen type reference - valid for current screen design.

Trellex LS-S PU side modules

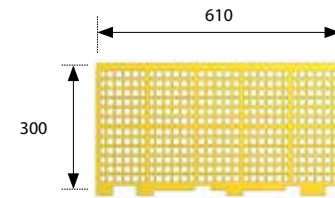

LS-S-300-610 (applied on** TS-range, RF/MF/LH)

Hole type	Side Module Width (mm)	Thickness screen area (mm)	Min web thickness with flow (mm)	Min web thickness cross flow (mm)	Build height (mm)	Part No. 75/90 (Sh-D/Sh-A) *	Part No. 75/80 (Sh-D/Sh-A) *
FR3.5EX	300	4	2	2	30	6681283	MM0359620
FR5EX	300	5	2	2.2	30	6681284	6681284.78
FR6EX	300	6	2.4	2.4	30	6681285	MM0359613
FR7EX	300	7	2.8	3.2	30	MM0365614	MM0365616
FR8EX	300	8	2.6	3.2	30	6681286	
FR9EX	300	9	3	3.5	30	6681375	MM0359618
FR10EX	300	10	3	4.2	30	Non standard	6681287
FR13EX	300	15	4.3	6	30		MM0344502
FR15EX	300	15	5	4.1	30		MM0354076
FR16EX	300	20	6.2	4.9	30		MM0354074
FR18EX	300	20	6.25	9	30		MM0359624
FR22EX	300	20	7	7.5	30		MM0354072
FR25EX	300	7	2.8	3.2	30		MM0369646

Other apertures on request.

* Missing part numbers issued on request.

** Screen type reference - valid for current screen design.

Trellex LS-S HiPer Drain PU side modules

Trellex LS-S-610

Machined from HiPer Drain modules

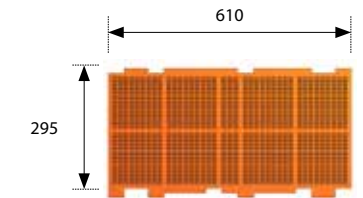

LS-S 295-610 (applied on** RF/MF/LH)

Hole type	Side Module Width (mm)	Thickness screen area (mm)	Min web thickness with flow (mm)	Min web thickness cross flow (mm)	Build height (mm)	Part No.*
ST50.3x11	295	8	2.9	2.45	40	MM0352791
ST50.5x11	295	8	2.9	2.45	40	MM0351364
ST50.63x11	295	8	2.9	2.45	40	6681606
ST50.8x11	295	8	2.9	2.5	40	6681607
SLS0.3x11	295	8	2.45	2.9	40	
SLS0.5x11	295	8	2.45	2.9	40	MM0350677
SLS0.63x11	295	8	2.45	2.9	40	MM0374167
SLS0.8x11	295	8	2.5	2.9	40	MM0360209

Other apertures on request.

* Missing part numbers issued on request.

** Screen type reference - valid for current screen design.

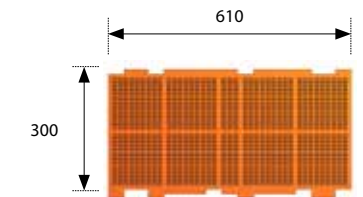

LS-S 300-610 (applied on** RF/MF/LH)

Hole type	Side Module Width (mm)	Thickness screen area (mm)	Min web thickness with flow (mm)	Min web thickness cross flow (mm)	Build height (mm)	Part No.*
ST50.3x11	300	8	2.9	2.45	40	MM0381792
ST50.5x11	300	8	2.9	2.45	40	MM0342111
ST50.63x11	300	8	2.9	2.45	40	
ST50.8x11	300	8	2.9	2.5	40	MM0342103
SLS0.3x11	300	8	2.45	2.9	40	
SLS0.5x11	300	8	2.45	2.9	40	MM0342110
SLS0.63x11	300	8	2.45	2.9	40	
SLS0.8x11	300	8	2.5	2.9	40	

Other apertures on request.

* Missing part numbers issued on request.

** Screen type reference - valid for current screen design.

Trellex LS PU side modules

Trellex LS 500/610

PU-cast, snap-on on both sides, standard range

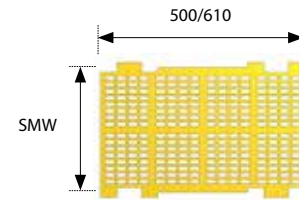

Part No.	Description (excl. Hole Size)	SMW Side module width (mm)	Build height (mm)	Length (mm)	Material *
Issued on request	150LS-500-30-PU	150	30,40	500	PU Open Cast
Issued on request	225LS-500-30-PU	225	30,40	500	PU Open Cast
Issued on request	275LS-500-30-PU	275	30,40	500	PU Open Cast
Issued on request	280LS-500-30-PU	280	30,40	500	PU Open Cast
Issued on request	330LS-500-30-PU	330	30,40	500	PU Open Cast
Issued on request	360LS-500-30-PU	360	30,40	500	PU Open Cast
Issued on request	400LS-500-30-PU	400	30,40	500	PU Open Cast
Issued on request	150LS-500-30-PU	150	30,40	610	PU Open Cast
Issued on request	225LS-500-30-PU	225	30,40	610	PU Open Cast
Issued on request	275LS-500-30-PU	275	30,40	610	PU Open Cast
Issued on request	280LS-500-30-PU	280	30,40	610	PU Open Cast
Issued on request	330LS-500-30-PU	330	30,40	610	PU Open Cast
Issued on request	360LS-500-30-PU	360	30,40	610	PU Open Cast
Issued on request	400LS-500-30-PU	400	30,40	610	PU Open Cast

Missing part numbers issued on request.

* PU Open Cast, Single Hardness 70, 80 or 90Sh-A

Refer to page 95 for available openings.

Trellex LS PU side modules

Trellex LS 500/610

Available openings

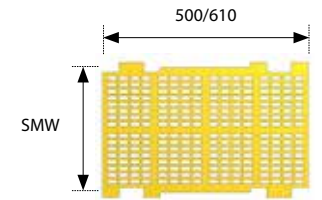

Aperture *	Build Height (mm)	Thickness (mm)
FR3.3	30,40	6
FR4.5	30,40	8
FR5.5	30,40	8
FR6.5	30,40	8
FR7.5	30,40	9
FR8.5	30,40	10
FR9.5	30,40	12
FR9.5LD	30,40	10
FR10	30,40	12
FR10.5LD	30,40	11
FR11	30,40	15
FR11.5LD	30,40	12
FR12.5	30,40	13
FR13.5	30,40	13
FR15	30,40	15
FR16.5	30,40	15
FR17.5	30,40	20
FR18.5	30,40	20
FR20	30,40	20
FR22	30,40	20
FR23	30,40	20
FR25	30,40	20
FR27.5	30,40	20
FR30	30,40	25
FR32	30,40	25
FR35	30,40	25
FR40	30,40	30
FR45	40	40
FR50	40	40

Other apertures on request.

* LD = Light Duty

Aperture **	Build height (mm)	Thickness (mm)
SLS/STS1x12	30,40	8
SLS/STS1.25x12	30,40	10
SLS/STS1.5x12	30,40	11
SLS/STS1.8x12	30,40	11
SLS/STS2x16	30,40	11
SLS/STS2x16/37	30,40	11
SLS/STS2.5x16	30,40	11
SLS/STS2.5x25HD	40	30
SLS/STS3x16	30,40	12
SLS/STS3x16HD	30,40	12
SLS/STS3.5x18	30,40	7
SLS/STS4x8	30,40	10
SLS/STS4x20	30,40	10
SLS/STS5x16	30,40	14
SLS/STS6x16	30,40	14
SLS/STS8x12	30,40	12
SLS/STS15x35	30,40	15
SLS/STS16x24	30,40	15
SLS/STS16x25	30,40	13
SLS/STS20x25	30,40	20
SLS/STS27x55	30,40	20

Other apertures on request.

** HD = Heavy Duty

Trellex LS PU side modules

Trellex 150/250LS-500

LS side modules used in rebuild-kits

Hole type	Thickness screen area (mm)	Relative Open Area (%)	Min web thickness with flow (mm)	Min web thickness cross flow (mm)	Build height (mm)	Material	Colour, Y=Yellow, B=Black	Module size 150LS-500	Module size 250LS-500
FR 3.3	6	39	2.8	2.8	30	PU90Sh-A	Y	MM0413180	
FR 4.5	8	41	2.5	2.5	30	PU90Sh-A	Y	MM0413181	
FR 5.5	8	43	2.9	2.9	30	PU90Sh-A	Y	MM0413184	
FR 6.5	8	47	3	3	30	PU90Sh-A	Y	MM0413185	
FR 7.5	9	51	3	3	30	PU90Sh-A	Y	MM0413187	
FR 8.5	10	55	3	3	30	PU90Sh-A	Y	MM0413188	
FR 9.5	12	43	3	3	30	PU90Sh-A	Y	MM0413189	
FR 10	12	44	5	5	30	PU90Sh-A	Y	MM0413191	
FR 11	15	44	5.5	5.5	30	PU90Sh-A	Y	MM0413198	
FR 12.5	13	39	7.5	7.5	30	PU90Sh-A	Y	MM0413199	
FR 13.5	13	46	6	6	30	PU90Sh-A	Y	MM0413200	
FR 15	15	43	8	8	30	PU90Sh-A	Y	MM0413202	
FR 16.5	15	50	6	6	30	PU90Sh-A	Y	MM0413203	
FR 17.5	20	39	10.5	10.5	40	PU90Sh-A	Y	MM0413218	
FR 18.5	20	43	10	10	30	PU90Sh-A	Y	MM0413204	
FR 20	20	51	8	8	30	PU90Sh-A	Y	MM0413205	
FR 22	20	39	11	11	30	PU90Sh-A	Y	MM0413206	
FR 23	20	41	13	13	30	PU90Sh-A	Y	MM0413207	
FR 25	20	51	10	10	30	PU80Sh-A	Y	MM0413208	
FR 27.5	20	47	8.5	8.5	30	PU80Sh-A	Y	MM0413209	
FR 30	25	37	19	19	40	PU80Sh-A	Y	MM0413210	
FR 32	25	41	18	18	40	PU80Sh-A	Y	MM0413211	
FR 35	25	52	13.5	13.5	40	PU80Sh-A	Y	MM0413214	
FR 40	30	44	20	20	40	PU80Sh-A	Y	MM0413215	
FR 45	40	36	30	30	40	PU80Sh-A	Y	MM0413216	
FR 50	40	44	25	25	40	PU80Sh-A	Y	MM0413217	
FR 30	25	37	19	19	40	PU80Sh-A	B	MM0413219	
FR 32	25	41	18	18	40	PU80Sh-A	B	MM0413220	
FR 35	25	52	13.5	13.5	40	PU80Sh-A	B	MM0413221	
FR 40	30	44	20	20	40	PU80Sh-A	B	MM0413223	
FR 45	40	36	30	30	40	PU80Sh-A	B	MM0413224	
FR 50	40	44	25	25	40	PU80Sh-A	B	MM0413225	

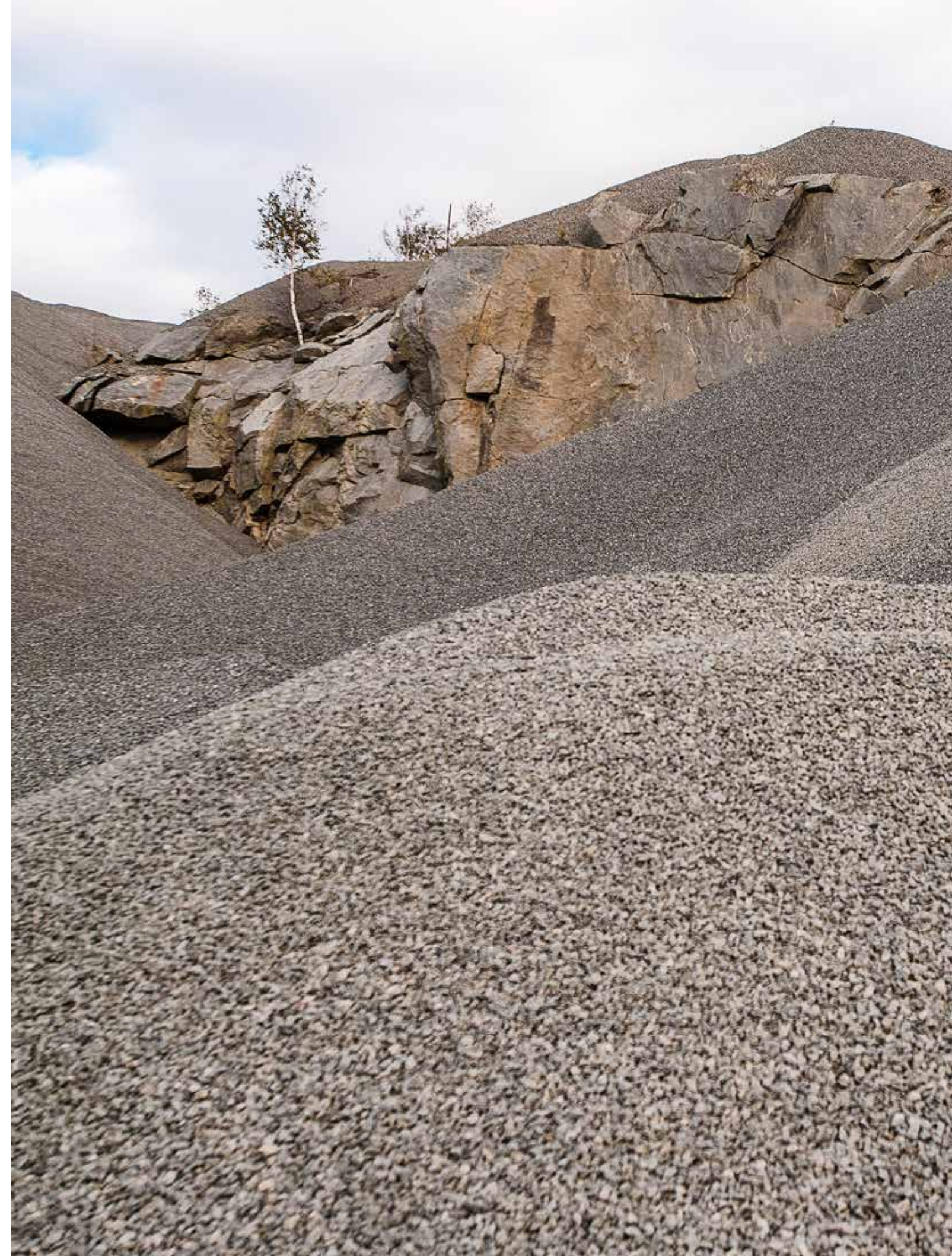

Trellex LS-S RU side modules

Trellex LS-S-500

Rubber 40°/60° Shore A - machined from standard modules (FR)

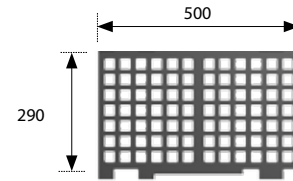

LS-S-290-500 (applied on** CVB1540/1845/2050/2060)

Hole type	Side Module Width (mm)	Thickness screen area (mm)	Min web thickness with flow (mm)	Min web thickness cross flow (mm)	Build height (mm)	Manufacturing country	Part No. (T40) *	Part No. (T60) *
FR3.2	290	4	2.8	3	30	SE	ZX11203346	
FR4.0	290	4	3.2	3.3	30	SE		MM0347456
FR4.8	290	4	3.7	3.8	30	SE	6681172	MM0350816
FR4.8-MK2	290	5	3.8	3.5	30	SE		
FR4.8-MK2	290	5	3.8	3.5	40	SE		
FR5.4	290	5	3.6	3.9	30	SE, BR	6670606-290	MM0347453
FR5.4-MK2	290	5	3.9	3.5	30	SE		
FR5.4-MK2	290	5	3.9	3.5	40	SE		
FR6.5	290	5	3.5	3.5	30	SE, BR	6681463	MM0392845
FR8.5	290	6	3.7	4	30	SE, BR	6681462	MM0392846
FR10	290	12	5.7	5.3	30	SE, BR	MM0392644	MM0392848
FR10	290	12	5.7	5.3	40	SE, BR		
FR12	290	12	6.6	6	30	SE	6670695-290	ZX11166098
FR12-MKII	290	12	6	6	30	BR		
FR12-MKII	290	12	6	6	40	BR		
FR13	290	12	6.4	6	30	SE	MM0392646	MM0392355
FR13	290	12	6.4	6	40	SE		MM0350841
FR14	290	20	7	7.6	30	SE	MM0392648	MM0344949
FR14	290	20	7	7.6	40	SE		MM0420072
FR16	290	20	6.3	6.9	30	SE, BR	MM0392649	MM0392353
FR16	290	20	6.3	6.9	40	SE, BR		MM0367428
FR18	290	20	10	7.3	30	SE, BR	MM0392652	MM0392342
FR18	290	20	10	7.3	40	SE, BR		
FR20	290	20	8.7	8	40	SE, BR	Non standard	6670852
FR20MK2	290	20	8	7	40	SE		
FR22	290	20	9.85	8	30	SE, BR		MM0375236
FR22	290	20	9.85	8	40	SE, BR		MM0375236
FR25	290	25	11.3	14	40	SE	Non standard	6670691-290
FR25HD	290	30	11.4	12	40	SE, BR		
FR30	290	25	17.5	12.6	40	SE, BR	Non standard	6670725-290
FR32	290	25	15	13.5	40	SE, BR	Non standard	6670850
FR35	290	30	17	16.3	40	SE, BR	Non standard	MM0354663
FR38	290	30	22.6	13.2	40	SE	Non standard	6681015-290
FR38HD	290	35	13.2	22	40	SE, BR	Non standard	
FR40	290	30	20	15.75	40	SE	Non standard	6670652-290
FR50	290	30	30.6	14.4	40	SE	Non standard	6670729-290
FR60	290	35	30.5	40	40	SE	Non standard	
FR60	290	35	30.5	40	60	SE	Non standard	

All side modules are punched except LS-S (290, 295, 300, 305) with molded aperture.

Other apertures on request.

* Missing part numbers issued on request.

** Screen type reference - valid for current screen design.

Trellex LS-S RU side modules

Trellex LS-S-500

Rubber 40°/60° Shore A - machined from standard modules (SLS)

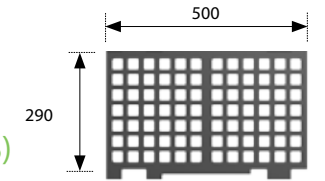

LS-S-290-500 (applied on** CVB1540/1845/2050/2060)

Hole type	Side Module Width (mm)	Thickness screen area (mm)	Min web thickness with flow (mm)	Min web thickness cross flow (mm)	Build height (mm)	Manufacturing country	Part No. (T40) *	Part No. (T60) *
SLS3x12,5	290	8	3,3	5,3	30	SE		
SLS3x12,5	290	8	3,3	5,3	40	SE		
SLS8x28,5	290	20	6,9	8	30	SE, BR	MM0393587	MM0393585
SLS8x28,5	290	20	6,9	8	40	SE, BR		
SLS10x25-MKII	290	20	8,1	13	30	BR		
SLS10x25-MKII	290	20	8,1	13	40	BR		
SLS12,5x27,5	290	25	8,6	9	30	SE, BR	MM0393586	MM0393583
SLS12,5x27,5	290	25	8,6	9	40	SE, BR		
SLS16x44	290	25	9,3	12	30	SE		
SLS16x44	290	25	9,3	12	40	SE		
SLS20x40	290	30	11,9	19	40	SE		MM0344948
SLS45x95	290	50	20	27,8	60	SE	Non standard	
SLS50x95	290	50	21,5	27,8	60	BR	Non standard	

All side modules are punched except LS-S (290, 295, 300, 305) with molded aperture.

Other apertures on request.

* Missing part numbers issued on request.

** Screen type reference - valid for current screen design.

SLS = With flow, STS = Cross flow

Trellex LS-S RU side modules

Trellex LS-S-610

Rubber 40°/60° Shore A - machined from standard modules (FR)

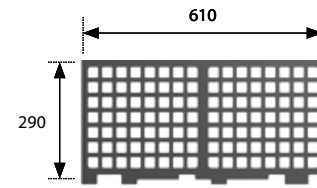

LS-S-290-610

Hole type	Side Module Width (mm)	Thickness screen area (mm)	Min web thickness with flow (mm)	Min web thickness cross flow (mm)	Build height (mm)	Manufacturing country	Part No. (T40) *	Part No. (T60) *
FR3.2	290	4	3	2.8	30	SE		
FR4.8	290	4	3.8	3.7	30	SE	6670637-290	MM0350817
FR4.8-MKII	290	5	3.8	3.5	30	SE		
FR4.8-MKII	290	5	3.8	3.5	40	SE		
FR5.4	290	5	3.9	3.6	30	SE, BR	6670657-290	6670607-290
FR5.4-MKII	290	5	3.9	3.5	30	SE		
FR5.4-MKII	290	5	3.9	3.5	40	SE		
FR6.5	290	5	4	3.6	30	SE, BR		
FR8.5	290	6	4	3.6	30	SE, BR		ZX11195524
FR10	290	12	5.7	5.3	30	SE, BR		
FR10	290	12	5.7	5.3	40	SE, BR		
FR12	290	12	6	7.5	30	SE	6670697-290	
FR12-MKII	4	12	6	6	30	BR		
FR12-MKII	4.5	12	6	6	40	BR		
FR13	290	12	6.4	6	30	SE		
FR13	290	12	6.4	6	40	SE		MM0350842
FR14	290	20	7	7.6	30	SE		MM0344950
FR14	290	20	7	7.6	40	SE		
FR16	290	20	6.9	6.3	30	SE, BR		
FR16	290	20	6.9	6.3	40	SE, BR		
FR18	290	20	10	7.3	30	SE, BR		
FR18	290	20	10	7.3	40	SE, BR		
FR20	290	20	8	8.4	40	SE, BR	Non standard	
FR20-MKII	290	20	8	7	40	SE		
FR22	290	20	9.85	8	30	SE, BR		
FR22	290	20	9.85	8	40	SE, BR		
FR25	290	25	11.3	10.6	40	SE	Non standard	6670692-290
FR25HD	290	30	11.4	12	40	SE, BR		
FR28	290	25	15	10.3	40	SE	Non standard	MM0349627
FR30	290	25	12.6	19	40	SE, BR	Non standard	MM0349626
FR32	290	25	13.5	16.6	40	SE, BR	Non standard	MM0350796
FR35	290	30	17	13	40	SE, BR	Non standard	
FR38	290	30	13.2	21.2	40	SE	Non standard	6681009-290
FR38HD	290	35	13.2	22	40	SE, BR		
FR40	290	30	15.8	18.7	40	SE	Non standard	6670654-290
FR45	290	35	20.5	19	40	SE, BR		
FR50	290	30	14.4	25	40	SE	Non standard	MM0365503
FR55	290	45	18.5	18.5	60	SE	Non standard	
FR64	290	35	22	34	60	SE	Non standard	ZX11195523

All side modules are punched except LS-S (290, 295, 300, 305) with molded aperture.

Other apertures on request.

* Missing part numbers issued on request.

Trellex LS-S RU side modules

Trellex LS-S-610

Rubber 40°/60° Shore A - machined from standard modules (SLS)

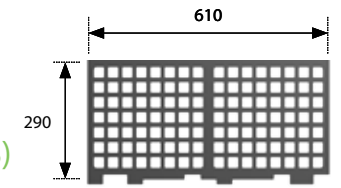

LS-S-290-610

Hole type	Side Module Width (mm)	Thickness screen area (mm)	Min web thickness with flow (mm)	Min web thickness cross flow (mm)	Build height (mm)	Manufacturing country	Part No. (T40) *	Part No. (T60) *
SLS3x12.5	290	8	3.3	5.3	30	SE		
SLS3x12.5	290	8	3.3	5.3	40	SE		
SLS5x17.5	290	10	4.7	4.9	40	SE		
SLS8x28.5	290	20	6.9	8	30	SE, BR		
SLS8x28.5	290	20	6.9	8	40	SE, BR		
SLS9.5x32	290	8.5	12.6	60	60	SE		
SLS10x25	290	25	8.1	9.5	40	SE		
SLS10x25M-MKII	290	20	8.1	13	30	BR		
SLS10x25M-MKII	290	20	8.1	13	40	BR		
SLS12.5x27.5	290	25	8.6	9	30	SE, BR		
SLS12.5x27.5	290	25	8.6	9	40	SE, BR		
SLS12.5x27.5HD	290	45	10	12	60	SE		
SLS12.5x36	290	20	8.6	12	40	SE	Non standard	
SLS14x56	290	25	11.5	15	40	SE		
SLS16x44	290	25	9.3	12	30	SE, BR		
SLS16x44	290	25	9.3	12	40	SE, BR		
SLS20x40	290	30	11.9	16	40	SE		MM0349622
SLS25x57	290	35	11.8	15	40	SE, BR		MM0349624
SLS25x78	290	35	19	22	40	SE		
SLS25x54	290	45	18.5	18	60	SE, BR		
SLS32x70	290	35	20	33	40	SE, BR	Non standard	
SLS35x105	290	45	31	45	60	SE	Non standard	
SLS40x70	290	35	26	30	40	BR	Non standard	MM0401206
SLS45x75	290	45	20.6	25	60	SE	Non standard	
SLS45x95	290	50	20	27.8	60	SE	Non standard	
SLS50x95	290	50	21.5	27.8	60	BR	Non standard	
SLS60x110	290	45	24.5	40	60	SE	Non standard	
SLS90/60x110						SE	Non standard	
SLS90x110	290	55	50	40	60	SE	Non standard	MM0401162

Other apertures on request.

* Missing part numbers issued on request.

SLS = With flow
STS = Cross flow

LS-S-500/610 side module options for punching (40°/60° Shore A)

Hole type	SMW Side Module Width (mm)	Length (mm)	Thickness screen area (mm)	Build height (mm)
Punched	100-400	500/610	2.5	30
Punched	100-400	500/610	3.5	30
Punched	100-400	500/610	5.5	30
Punched	100-400	500/610	8	30
Punched	100-400	500/610	11	30
Punched	100-400	500/610	15	40
Punched	100-400	500/610	20	40
Punched	100-400	500/610	25	40
Punched	100-400	500/610	35	60
Punched	100-400	500/610	45	60

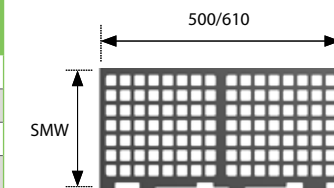

This table is valid for length 500 and 610.

Trellex LS-S RU side modules

Trellex LS-S-610

Rubber 40°/60° Shore A - machined from standard modules (FR)

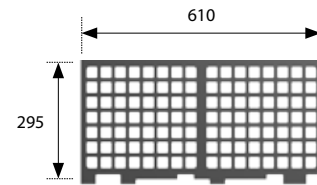

LS-S-295-610 (applied on** LH, MF, RF)

Hole type	Side Module Width (mm)	Thickness screen area (mm)	Min web thickness with flow (mm)	Min web thickness cross flow (mm)	Build height (mm)	Manufacturing country	Part No. (T40) *	Part No. (T60) *
FR3.2	295	4	3	2.8	30	SE		
FR4.8	295	4	3.8	3.7	30	SE		
FR4.8-MKII	295	5	3.8	3.5	30	SE	ZX11384101	
FR4.8-MKII	295	5	3.8	3.5	40	SE		
FR5.4	295	5	3.9	3.6	30	SE, BR	6670742	
FR5.4-MKII	295	5	3.9	3.5	30	SE		
FR5.4-MKII	295	5	3.9	3.5	40	SE		
FR6.5	295	5	4	3.6	30	SE, BR	6670668	
FR8.5	295	6	4	3.6	30	SE, BR	MM0378461	
FR10	295	12	5.7	5.3	30	IN, SE, BR		MM0380429
FR10	295	12	5.7	5.3	40	IN, SE, BR	MM0404394	MM0403960
FR12 MKII	295	12	6	6	30	IN, US, BR	MM0402692	
FR12 MKII	295	12	6	6	40	IN, US, BR		MM0402691
FR12	295	12	6	7.5	30	SE	6670741	6670864
FR13	295	12	6.4	6	30	SE		
FR13	295	12	6.4	6	40	SE		
FR14	295	20	7	7.6	30	SE		
FR14	295	20	7	7.6	40	SE		MM0363110
FR16	295	20	6.9	6.3	30	SE, IN, BR		
FR16	295	20	6.9	6.3	40	SE, IN, BR	MM0353504	MM0358606
FR18	295	20	10	7.3	30	SE, US, BR		
FR18	295	20	10	7.3	40	SE, US, BR	MM0384861	ZX11286117
FR20	295	20	8	8.4	40	SE, BR	Non standard	6670716-295
FR20-MK2	295	20	8	7	40	SE		
FR22	295	20	9.85	8	30	SE, BR		
FR22	295	20	9.85	8	40	SE, BR	MM0396603	MM0371461
FR25	295	25	11.3	10.6	40	SE	Non standard	6670690-295
FR25HD	295	30	11.4	12	40	SE, US, BR		MM0360876
FR28	295	25	15	10.3	40	SE		MM0380172
FR30	295	25	12.6	19	40	SE, BR		6681557
FR32	295	25	13.5	16.6	40	SE, BR		6670839
FR32-MKII	295	30	13.5	15.3	40	US	25-582-172-033	
FR35	295	30	17	13	40	SE, BR		6670723-295
FR38	295	30	13.2	21.2	40	SE		6641608
FR38HD	295	35	13.2	21.2	40	SE, BR		MM0393042
FR40	295	30	15.8	18.7	40	SE		6681008
FR40HD	295	35	15.6	18.5	40	IN, US		
FR45	295	35	20.5	19	40	SE, BR		
FR50	295	30	14.4	25	40	SE, US		6670718-295
FR55	295	45	18.5	18.5	60	SE		MM0363745
FR60	295	35	30	40	40	SE		
FR60	295	35	30	40	60	SE		
FR64	295	35	22	34	60	SE		MM0363743
FR64-MKII	295	50	24	36	60	SE		
FR76	295	50	26.5	24	60	SE		MM0416169

Non standard

All side modules are punched except LS-S (290, 295, 300, 305) with molded aperture.

Other apertures on request.
SLS = With flow
STS = Cross flow

* Missing part numbers issued on request.

** Screen type reference - valid for current screen design.

Trellex LS-S RU side modules

Trellex LS-S-610

Rubber 40°/60° Shore A - machined from standard modules (SLS)

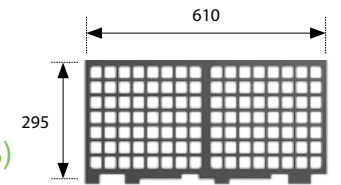

LS-S-295-610 (applied on** LH, MF, RF)

Hole type	Side Module Width (mm)	Thickness screen area (mm)	Min web thickness with flow (mm)	Min web thickness cross flow (mm)	Build height (mm)	Manufacturing country	Part No. (T40) *	Part No. (T60) *
SLS3x12,5	295	8	3,3	5,3	30	SE		
SLS3x12,5	295	8	3,3	5,3	40	SE	MM0405445	
SLS5x17,5	295	10	4,7	4,9	40	IN, SE	ZX11155530	ZX11155526
SLS8x28,5	295	20	6,9	8	30	IN, BR, US, SE		
SLS8x28,5	295	20	6,9	8	40	IN, BR, US, SE	MM0348438	MM0348437
SLS9,5x32	295	45	8,5	12,6	60	SE, US		
SLS10x25MKII	295	20	8,1	13	30	IN, BR, US		
SLS10x25MKII	295	20	8,1	13	40	IN, BR, US	MM0380192	MM0384250
SLS10x25	295	25	8,1	9,5	40	SE	6670891-295	6670890-295
SLS12,5x27,5	295	25	8,6	9	30	IN, BR, US, SE		
SLS12,5x27,5	295	25	8,6	9	40	IN, BR, US, SE	MM0353501	MM0358608
SLS12,5x27,5HD	295	45	10	12	60	US, SE		MM0361935
SLS12,5x36	295	20	8,6	12	40	SE	Non standard	6670687
SLS14x56	295	25	11,5	15	40	SE	MM0427807	MM0381468
SLS16x44	295	25	9,4	12	30	IN, BR, SE		MM0408519
SLS16x44	295	25	9,4	12	40	IN, BR, SE	MM0371044	MM0380438
SLS20x40	295	30	11,9	16	40	IN, US, SE	MM0370850	MM0344958
SLS20x50	295	45	17	24	60	IN		MM0383382
SLS25x57	295	35	11,8	15	40	BR, US, SE	MM0380205	MM0347605
SLS25x78	295	35	19	22	40	SE		MM0362324
SLS25x54	295	45	18,5	18	60	BR, SE		MM0372754
SLS30x65	295	55	22	35	60	IN		MM0419974
SLS32x70	295	35	20	33	40	BR, SE		MM0353499
SLS35x105	295	45	31	45	60	SE		MM0363744
SLS36x65	295	55	29,5	35	60	IN, US		MM0395139
SLS40x70	295	35	26	30	40	IN, BR		
SLS45x75	295	45	20,6	25	60	SE		MM0363742
SLS45x95	295	50	20	27,8	60	SE		MM0371539
SLS50x95	295	50	21,5	27,8	60	BR		MM0372478
SLS60x110	295	45	24,5	40	60	US, SE		MM0380565
SLS90/60x110 LH	295	55/45	24,5	40	60	SE		MM0380551
SLS90/60x110 RF	295	55/45	24,5	40	60	SE		MM0397993
SLS90x110	295	55	50	40	60	SE		MM0392349
FR64-MKII	295	50	24	36	60	SE		
FR76	295	50	26.5	24	60	SE		MM0416169

Non standard

All side modules are punched except LS-S (290, 295, 300, 305) with molded aperture.

* Tooling location: IN=Alwar, India, BR=Sorocaba, Brazil, SE=Trelleborg, Sweden

Other apertures on request.
SLS = With flow, STS = Cross flow

** Missing part numbers issued on request.

*** Screen type reference - valid for current screen design.

Trellex LS modular system

Trellex LS accessories

The Trellex LS system offers a wide range of standard options that enables you to customize your screen deck according to your needs.

- Side wall protection
- Ledge angle strips
- Modular discharge lips
- Longitudinal rails
- Upgrade strips
- Surface features – dambars for dewatering and wet screening applications and deflectors to direct material into screening area
- Anti blinding rods to prevent screendeck from blinding and pegging



Trellex LS – accessories

Side wall protection

Side wall protection is required in all modular screen media installations. Depending on the type of screen and screen design, side wall protection is often a part of the attachment system.

There are several alternatives when it comes to height, thickness and material.

The most common is wedge-down attachment, either with flat or chamfered top side. Wedge-down is standard on Metso screens.



PU sideliners with chamfer top for Metso MF, mining screens



PU sideliners for flat top for CVB or TS screens

Trellex LS – accessories

Side wall protection

Wedge-down sideliners – flat top

- Standard sideliners for construction screens
- Available in both polyethene (PE) and polyurethane (PU)

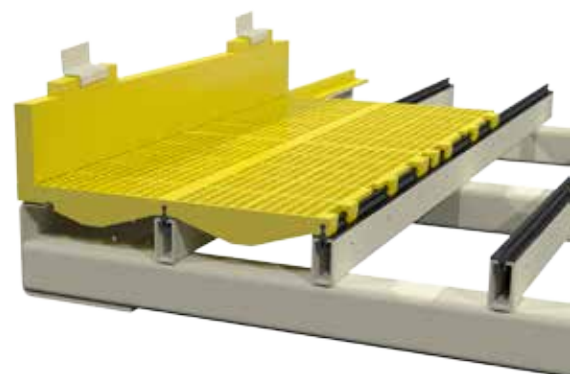

Side wall protection - standard range

Part No.	Description	Weight (kg)	Liner dimension (mm)	Material
MM0394600	LS SL-PU-40-80-1000-F	6.2	40x80x1000	PU 80Sh-A
6681440	LS SL-PU-40-100-1000-F	7.4	40x100x1000	PU 90Sh-A
6681487	LS SL-PU-40-100-1220-F	9.0	40x100x1220	PU 90Sh-A
6681429	LS SL-PU-40-100-1525-F	11.3	40x100x1525	PU 90Sh-A
6620642	LS SL-PU-40-150-1000-F	11.4	40x150x1000	PU 80Sh-A
424712.38	LS SL-PU-40-150-1220-F	13.5	40x150x1220	PU 90Sh-A
6681430	LS SL-PU-40-150-1525-F	16.5	40x150x1525	PU 90Sh-A
6681439	LS SL-PU-40-200-1000-F	15.3	40x200x1000	PU 80Sh-A
6681428	LS SL-PU-40-200-1220-F	17.3	40x200x1220	PU 90Sh-A
ZX11252180	LS SL-PE-40-80-1000 F	3.0	40x80x1000	PE (UHMW)
670136	LS SL-PE-40-100-1000-F	3.7	40x100x1000	PE (UHMW)
6680416	LS SL-PE-40-100-1220-F	4.8	40x100x1220	PE (UHMW)
6620629	LS SL-PE-40-100-1525-F	5.5	40x100x1525	PE (UHMW)
670088	LS SL-PE-40-150-1000-F	5.6	40x150x1000	PE (UHMW)
424506.3	LS SL-PE-40-150-1220-F	9.0	40x150x1220	PE (UHMW)
6680783	LS SL-PE-40-150-1525-F	11.0	40x150x1525	PE (UHMW)
6680106	LS SL-PE-40-200-1000-F	8.0	40x200x1000	PE (UHMW)
6680418	LS SL-PE-40-200-1220-F	9.1	40x200x1220	PE (UHMW)

PU wedges for flat top sideliners

Part No.	Description	Width	Length	Height 1	Height 2
6670688	LS-ACC-WEDGE-40-20-40-200 Dual hardness	40	200	20	40
6680535	LS-ACC-WEDGE-40-15-30-200	40	200	15	30



Discharge end side liners - Classic "GfA" Screens

Part No.	Description	Weight (kg)	Liner dimension (mm)	Material*
MM0395685	LS SL-PU-40-80-1150-F		40x80x1150	PU 80Sh-A
	LS SL-PU-40-100-1150-F		40x100x1150	PU 80Sh-A
	LS SL-PU-40-150-1150-F		40x150x1150	PU 80Sh-A
ZX11252241	LS SL-PE-40-80-1150 F		40x80x1150	PE (UHMW)
MM0371129	LS SL-PE-40-100-1150-F		40x100x1150	PE (UHMW)
670134	LS SL-PE-40-150-1150-F		40x150x1150	PE (UHMW)

Other dimensions on request.



Modular system

Side wall protection - standard range Metso ES Screens

Part No.	Description	Weight (kg)	Liner dimension (mm)	Material*	Screen model	Deck Position
MM0375800	LS SL-PU-50-150-1219-F	16.2	50x150x1220	PU 70Sh-A	ES20X. 30X. 40X	Top Deck
MM0395113	LS SL-PU-50-100-1219-F	10.7	50x100x1220	PU 70Sh-A	ES20X. 30X. 40X	Lower decks
MM0396817	LS SL-RU-50-150-1219-F	16.0	50x150x1220	T60	ES20X. 30X. 40X	Top Deck
MM0396818	LS SL-RU-50-100-1219-F	10.0	50x100x1220	T60	ES20X. 30X. 40X	Lower decks

Side wall protection - standard range Metso CVB Screens

Part No.	Description	Weight (kg)	Liner dimension (mm)	Material*	Screen model	Deck Position
6681432	LS SL-PU-60-150-1000-F	15.0	60x150x1000	PU 90Sh-A	CVB1540. 1845. 2050/60	Top deck
6681431	LS SL-PU-60-100-1000-F	10.4	60x100x1000	PU 90Sh-A	CVB1540. 1845. 2050/60	Lower decks
MM0375800	LS SL-PU-50-150-1219-F	16.2	50x150x1220	PU 70Sh-A	CVB20X. 30X. 40X. 50X	All decks
MM0396817	LS SL-RU-50-150-1219-F	16.2	50x150x1220	T60	CVB20X. 30X. 40X. 50X	All decks
6681436	LS SL-PU-60-150-1220-F	18.3	60x150x1220	PU 90Sh-A	CVB2661	Top deck
6681435	LS SL-PU-60-100-1220-F	12.7	60x100x1220	PU 90Sh-A	CVB2661	Lower decks
6681490	LS SL-PU-60-150-1500-F	22.5	60x150x1500	PU 90Sh-A	CVB1845	Top deck
6681488	LS SL-PU-60-100-1500-F	15.6	60x100x1500	PU 90Sh-A	CVB1845	Lower decks
6680550	LS SL-PE-60-150-1000-F	8.4	60x150x1000	PE (UHMW)	CVB1540. 1845. 2050/60	Top deck
6680591	LS SL-PE-60-100-1000-F	5.6	60x100x1000	PE (UHMW)	CVB1540. 1845. 2050/60	Lower decks
6680530	LS SL-PE-60-150-1220-F	10.2	60x150x1220	PE (UHMW)	CVB2661	Top deck
6680529	LS SL-PE-60-100-1220-F	6.8	60x100x1220	PE (UHMW)	CVB2661	Lower decks
6680925	LS SL-PE-60-150-1500-F	16.2	60x150x1500	PE (UHMW)	CVB1845	Top deck
6690005	LS SL-PE-60-100-1500-F	8.4	60x100x1500	PE (UHMW)	CVB1845	Lower decks

Side wall protection - standard range Metso TS Screens

Part No.	Description	Weight (kg)	Liner dimension (mm)	Material *	Screen Model	Feed end angle (deg)	Discharge end angle (deg)
6681464	LS SL-PU-60-150-1828/1815-F-92.5-92.5	28.6	60x150x1830	PU 90Sh-A	TS2.X	2.5	2.5
6681465	LS SL-PU-60-150-1000-2.5-0-F	15.6	60x150x1000	PU 90Sh-A	TS3.X. TS4.X	2.5	0.0
6681466	LS SL-PU-60-150-1000-0-2.5-F	15.6	60x150x1000	PU 90Sh-A	TS3.X. TS4.X	0.0	2.5
MM0345424	LS SL-PU-60-150-1220/1213-90-92.5	18.2	60x150x1220	PU 90Sh-A	TS5.X. TS6.X	0.0	2.5
MM0345425	LS SL-PU-60-150-1220/1213-92.5-90	18.2	60x150x1220	PU 90Sh-A	TS5.X. TS6.X	2.5	0.0
MM0345466	LS SL-PU-60-150-1500/1493-90-92.5	22.5	60x150x1500	PU 90Sh-A	TS5.X. TS6.X	0.0	2.5
MM0345465	LS SL-PU-60-150-1500/1493-92.5-90	22.5	60x150x1500	PU 90Sh-A	TS5.X. TS6.X	2.5	0.0
6681393	LS SL-PE-60-150-1830-F	15.3	60x150x1830	PE (UHMW)	TS2.X	2.5	2.5
423300.336	LS SL-PE-60-150-1000/993 F	9.0	60x150x1000	PE (UHMW)	TS3.X. TS4.X	2.5	0.0
6681070	LS SL-PE-60-150-1220-0-3	10.0	60x150x1220	PE (UHMW)	TS5.X. TS6.X	0.0	2.5
6681071	LS SL-PE-60-150-1500-0-3	13.0	60x150x1500	PE (UHMW)	TS5.X. TS6.X	2.5	0.0

* Side liners PU 90 Sh-A, exist in left/right hand version due to internal steel backing.
Side liners PE, no left/right hand version (no steel backing internally).

Other dimensions on request.

Trellex LS – accessories

Side wall protection

Wedge-down sideliners – chamfer top with overlap

- Made to suit angle change on Multi-Slope Banana screens
- Can be made to fit as feed box sidelinings
- Works both with Trellex LS and Trellex MP

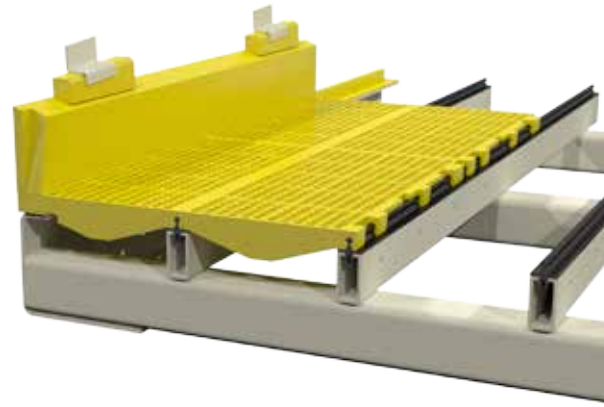

Wedge retaining brackets

Part No.	Part No. (OEM)	Description	Weight (kg)	Remark
MM0364174	MM0610140	SM-ACC STEEL CLAMP FOR PU WEDGE - RH	1.2	Feed box, Right Hand
MM0364175	MM0610144	SM-ACC STEEL CLAMP FOR PU WEDGE - LH	1.2	Feed box, Left Hand
MM0364380	MM0601602	SM-ACC STEEL CLAMP FOR PU WEDGE - RH	1.2	Side lining, Right hand
MM0364385	MM0609220	SM-ACC STEEL CLAMP FOR WEDGE - LH	1.2	Side lining, Left hand

PU wedges



Part No.	Part No. (OEM)	Description	Weight (kg)	Remark
6681339	MM0609221	LS-ACC-WEDGE-40-48-32-220-PU75/90-L	0.5	Left hand
6681340	MM0608964	LS-ACC-WEDGE-40-48-32-220-PU75/90-R	0.5	Right hand

Side wall protection with overlap - standard range Metso mining screens (RF, LH, MF) - PU

Part No.	Part No. OEM **	Description	Weight (kg)	Dimension (mm)	Material	Colour	Attachment method	Feed end angle (deg)	Discharge end angle (deg)
MM0351357	N/A	LS SL-PU-50-150-1175-AV	15.3	50x150x1175	PU 70Sh-A	Yellow	Wedge	Variable	Variable
MM0351358	N/A	LS SL-PU-50-150-1220-AV	15.8	50x150x1220	PU 70Sh-A	Yellow	Wedge	Variable	Variable
MM0351359	N/A	LS SL-PU-50-150-1525-AV	19.9	50x150x1525	PU 70Sh-A	Yellow	Wedge	Variable	Variable
MM0424591	MM0622844	LS SL-PU-50-150-1220-AV-MECH	14.8	50x150x1220	PU 70Sh-A	Black	Bolt*)	Variable	Variable
MM0349041	N/A	LS SL-PU-50-300-1175-AV	31.2	50x300x1175	PU 70Sh-A	Yellow	Wedge	Variable	Variable
MM0357829	N/A	LS SL-PU-50-300-1220-AV-MECH	31.3	50x300x1220	PU 70Sh-A	Yellow	Bolt*	Variable	Variable
MM0349039	N/A	LS SL-PU-50-300-1220-AV	32.4	50x300x1220	PU 70Sh-A	Yellow	Wedge	Variable	Variable
MM0349040	N/A	LS SL-PU-50-300-1525-AV	40.7	50x300x1525	PU 70Sh-A	Yellow	Wedge	Variable	Variable

Side wall protection with overlap - standard range Metso mining screens (RF, LH, MF) - RU

Part No.	Part No. OEM **	Description	Weight (kg)	Dimension (mm)	Material	Attachment method	Feed end angle (deg)	Discharge end angle (deg)
MM0351587	MM0614856	LS SL-RU-50-150-1175-AV	14.6	50x150x1175	T60	Wedge	Variable	Variable
MM0351593	MM0614851	LS SL-RU-50-150-1220-AV	15.2	50x150x1220	T60	Wedge	Variable	Variable
MM0351594	MM0614859	LS SL-RU-50-150-1525-AV	19	50x150x1525	T60	Wedge	Variable	Variable
MM0424645	MM0622109	LS SL-RU-50-200-1175-AV	18,8	50x200x1175	T60	Wedge	Variable	Variable
MM0424664	MM0620962	LS SL-RU-50-200-1220-AV	19,5	50x200x1220	T60	Wedge	Variable	Variable
MM0424675	10176900-500	LS SL-RU-50-200-1525-AV	25,8	50x200x1525	T60	Wedge	Variable	Variable
MM0351579	MM0603950	LS SL-RU-50-300-1175-AV	30	50x300x1175	T60	Wedge	Variable	Variable
ZX11388356	MM0603264	LS SL-RU-50-300-1203-AV-SPEC-RH	29,0	50x300x1203	T60	Wedge	15	Variable
ZX11388355	MM0603268	LS SL-RU-50-300-1203-AV-SPEC-LH	29,0	50x300x1203	T60	Wedge	15	Variable
MM0351582	MM0615712	LS SL-RU-50-300-1220-AV-MECH	30	50x300x1220	T60	Bolt*	Variable	Variable
MM0351581	MM0602801	LS SL-RU-50-300-1220-AV	30	50x300x1220	T60	Wedge	Variable	Variable
MM0351580	MM0602827	LS SL-RU-50-300-1525-AV	39.1	50x300x1525	T60	Wedge	Variable	Variable

* Bolted sideliners only for RF-screens bottom decks under mechanism.

** Part No. OEM relates to originally issued parts included in spare parts lists.

Trellex LS – accessories

Side wall protection

Wedge-down sideliners – chamfer top

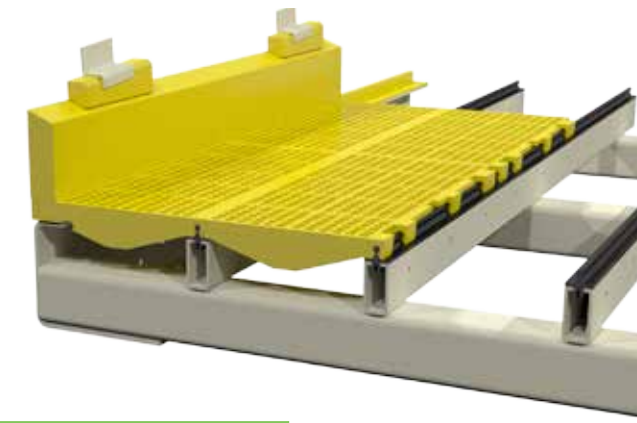

Side wall protection - fixed angle change -PU

Part No.	Description	Weight (kg)	Dimension (mm)	Feed end angle (deg.)	Discharge end angle (deg.)
ZX11204489	LS SL-PU-50-150-1190-0-0	15.1	50x150x1190	0	0
MM0342932	LS SL-PU-50-150-1220-0°-0°	15.5	50x150x1220	0	0
MM0342933	LS SL-PU-50-150-1525-0°-0°	19.3	50x150x1525	0	0
424610.398	LS SL-PU-50-150-1175-1-1	15.9	50x150x1175	1	1
424610.397	LS SL-PU-50-150-1220-1-1	16.5	50x150x1220	1	1
424610.399	LS SL-PU-50-150-1525-1-1	20.7	50x150x1525	1	1
6670862	LS SL-PU-50-200-1220-0-0-F	21.1	50x200x1220	0	0
6670863	LS SL-PU-50-200-1525-0-0-F	26.4	50x200x1525	0	0
424712.26	LS SL-PU-50-300-1220-0-0	31.3	50x300x1220	0	0
424712.28	LS SL-PU-50-300-1525-0-0	39.1	50x300x1525	0	0
424712.48	LS SL-PU-50-300-1175-1-1	30.0	50x300x1175	1	1
424712.53	LS SL-PU-50-300-1220-1-1	26.0	50x300x1220	1	1
424712.46	LS SL-PU-50-300-1525-1-1	38.9	50x300x1525	1	1
423300.465	LS SL-PU-50-300-1220-1-1 MECH*	38.1	50x300x1220	1	1
424712.77	LS SL-PU-50-300-1175-2-2	22.0	50x300x1175	2	2
424712.78	LS SL-PU-50-300-1220-2-2	31.0	50x300x1220	2	2
424712.79	LS SL-PU-50-300-1525-2-2	39.0	50x300x1525	2	2
ZX11196615	LS SL-PU-50-260-1220-2-2 MECH*)	28.0	50x260x1220	2	2
MM0342384	LS SL-PU-50-300-1220-2-2-5XM12*	30.6	50x300x1220	2	2
ZX11163801	LS SL-PU-50-300-1175-3-3	29.6	50x300x1175	3	3
424561.22	LS SL-PU-50-300-1220-3-3	30.7	50x300x1220	3	3
424561.21	LS SL-PU-50-300-1525-3-3	38.9	50x300x1525	3	3

Side wall protection - fixed angle change -RU

Part No.	Description	Weight (kg)	Dimension (mm)	Feed end angle (deg.)	Discharge end angle (deg.)
MM0379742	LS SL-RU-50-150-1220-AV-0-0	15.2	50x150x1220	0	0
MM0380481	LS SL-RU-50-150-1175-AV-1-1	14.8	50x150x1175	1	1
MM0380482	LS SL-RU-50-150-1220-AV-1-1	15.3	50x150x1220	1	1
MM0380483	LS SL-RU-50-150-1525-AV-1-1	19.1	50x150x1525	1	1
MM0373148	LS SL-SL-RU-50-200-1190-91.4-91.4	21	50x200x1190	1.4	1.4
MM0395231	LS SL-RU-50-200-1175-SPECIAL	19,2	50x200x1175	1,4	1,4
MM0373152	LS SL-SL-RU-50-200-1220-91.4-91.4	21	50x200x1220	1.4	1.4
MM0373144	LS SL-SL-RU-50-200-1525-91.4-91.4	27	50x200x1525	1.4	1.4
MM0380485	LS SL-RU-50-270-1175-AV-1-1	27.2	50x270x1175	1	1
MM0380486	LS SL-RU-50-270-1220-AV-1-1	28.3	50x270x1220	1	1
MM0380487	LS SL-RU-50-270-1525-AV-1-1	35.4	50x270x1525	1	1
MM0373129	LS SL-SL-RU-50-300-1190-91.4-91.4	32	50x300x1190	1.4	1.4
MM0373141	LS SL-SL-RU-50-300-1220-91.4-91.4	32	50x300x1220	1.4	1.4
MM0371465	LS SL-RU-50-300-1220-AV-0-0	31.7	50x300x1220	0	0

Trellex LS – accessories

Side wall protection

Grooved sideliners

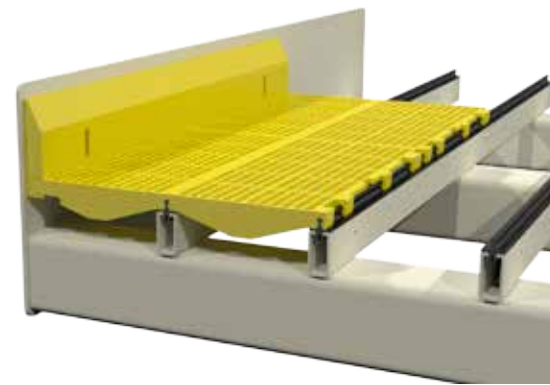

■ For screens without ledge angle support

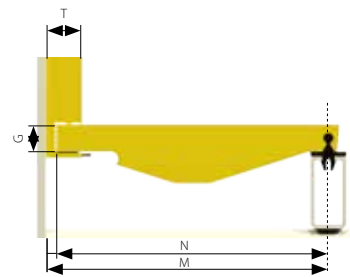

M = Distance between side wall and center of rail
 N = Width of side module (M - 15)
 G = Groove height (30, 40, 60)
 T = Liner width

Part No.	Description	Weight (kg)	Liner length (mm)	Liner width (mm)	Liner height above deck (mm)	Groove height (mm)
MM0381361	LS SL-PU-40-190-400-F-0-0-BG40-LH	5.8	400	40	190	40
MM0381362	LS SL-PU-40-190-400-F-0-0-BG40-RH	5.8	400	40	190	40
ZX11184810	LS SL-PU-40-150-500-F-0-0-BG30	5	500	40	150	30
ZX11184807	LS SL-PU-40-150-500-F-0-0-BG30-LH	5	500	40	150	30
ZX11184809	LS SL-PU-40-150-500-F-0-0-BG30-RH	5	500	40	150	30
6620721	LS SL-PU-40-100-500-F-0-0-BG30	4	500	40	100	30
ZX11184861	LS SL-PU-40-150-650-F-0-0-BG30-LH	6	650	40	150	30
ZX11184862	LS SL-PU-40-150-650-F-0-0-BG30-RH	6	650	40	150	30
MM0371605	LS SL-PU-40-100-915-F-0-0-BG40-2XM16	7.3	915	40	100	40
6620719	LS SL-PU-40-100-1000-F-0-0-BG30	7.8	1000	40	100	30
66811316	LS SL-PU-40-100-1000-F-0-0-BG40	8	1000	40	100	40
6681502	LS SL-PU-40-100-1000-F-90-90-BG60	8.8	1000	40	100	60
6670847.BENT	LS SL-PU-40-150-1000-0-0-F-BG30-4X18/40	10.4	1000	40	150	30
6620657.BENT	LS SL-PU-40-150-1000-90-90-F-BG40	11.4	1000	40	150	40
MM0381343	LS SL-PU-40-150-1000-F-0-0-BG30	10	1000	40	150	30
6620718.BENT	LS SL-PU-40-150-1000-F-90-90-BG30	11.3	1000	40	150	30
6681503.BENT	LS SL-PU-40-150-1000-F-90-90-BG60	12.2	1000	40	150	60
MM0378477	LS SL-PU-40-200-1000-F-0-0-BG30	14.8	1000	40	200	30
6681496.BENT	LS SL-PU-40-200-1000-F-0-0-BG40	14.8	1000	40	200	40
6681492.BENT	LS SL-PU-40-200-1000-F-90-90-BG30	14.7	1000	40	200	30
6681504.BENT	LS SL-PU-40-200-1000-F-90-90-BG60	15.6	1000	40	200	60
6681446-1110	LS SL-PU-40-100-1110-0-0-F-BG30	8	1110	40	100	30
6670768	LS SL-PU-40-100-1150-0-0-F-BG30	8	1150	40	100	30

Continued from previous page

Part No.	Description	Weight (kg)	Liner length (mm)	Liner width (mm)	Liner height above deck (mm)	Groove height (mm)
6670848.BENT	LS SL-PU-40-150-1150-0-0-F-BG30-4X18/40	11.5	1150	40	150	30
66811315-1150.BENT	LS SL-PU-40-150-1150-90-90-F-BG30	11.9	1150	40	150	30
66811315-1175	LS SL-PU-40-150-1175-0-0-F-BG30	12.2	1175	40	150	30
6681446	LS SL-PU-40-100-1220-F-0-0-BG30	9.6	1220	40	100	30
6681498	LS SL-PU-40-100-1220-F-90-90-BG40	9.8	1220	40	100	40
6681505	LS SL-PU-40-100-1220-F-90-90-BG60	10.8	1220	40	100	30
66811315.BENT	LS SL-PU-40-150-1220-F-90-90-BG30	13.7	1220	40	150	30
6681499.BENT	LS SL-PU-40-150-1220-F-90-90-BG40	13.9	1220	40	150	40
6681506.BENT	LS SL-PU-40-150-1220-F-90-90-BG60	14.9	1220	40	150	60
MM0366815	LS SL-PU-40-200-1220-F-0-0-BG40-3X20/40	17.8	1220	40	200	40
MM0366812	LS SL-PU-40-200-1220-F-0-0-BG40-4X20/40	17.8	1220	40	200	40
6681494.BENT	LS SL-PU-40-200-1220-F-90-90-BG30	17.9	1220	40	200	30
6681500.BENT	LS SL-PU-40-200-1220-F-90-90-BG40	18	1220	40	200	40
6681507.BENT	LS SL-PU-40-200-1220-F-90-90-BG60	19	1220	40	200	60
6670765	LS SL-PU-40-210-1000-0-0-F-BG30	14.7	1000	40	210	30
6670766	LS SL-PU-40-210-1150-0-0-F-BG30	16.7	1150	40	210	30
6681493.BENT	LS SL-PU-40-250-1000-F-90-90-BG30	18	1000	40	250	30
6681497.BENT	LS SL-PU-40-250-1000-F-90-90-BG40	18.2	1000	40	250	40
66811317.BENT	LS SL-PU-40-250-1000-F-90-90-BG60	19	1000	40	250	60
6681495.BENT	LS SL-PU-40-250-1220-F-90-90-BG30	22	1220	40	250	30
6681501.BENT	LS SL-PU-40-250-1220-F-90-90-BG40	22.2	1220	40	250	40
6681508.BENT	LS SL-PU-40-250-1220-F-90-90-BG60	23.2	1220	40	250	60

For US-version of Metso FS-screens

Part No.	Description	Groove height (mm)	Weight (kg)	Liner length (mm)	Liner width (mm)	Liner height above deck (mm)
MM0356595	LS SL-PU-85-150-1220-F-0-0-BG60-4X20/40	60	21	1220	85	150
MM0344763	LS SL-PU-85-150-1220-F-0-0-BG40-4X20/40	40	22	1220	85	150
MM0344761	LS SL-PU-85-150-1220-F-0-0-BG30-4X20/40	30	21	1220	85	150
MM0344755	LS SL-PU-85-100-1220-F-0-0-BG40-4X20/40	40	17	1220	85	100
MM0344765	LS SL-PU-85-100-1220-F-0-0-BG30-4X20/40	30	16	1220	85	100

Trellex LS – accessories

Side wall protection

Snap-on sideliners

- Snap-on side wall protection
- Installed directly on upgrade strip
- Independent of rail type

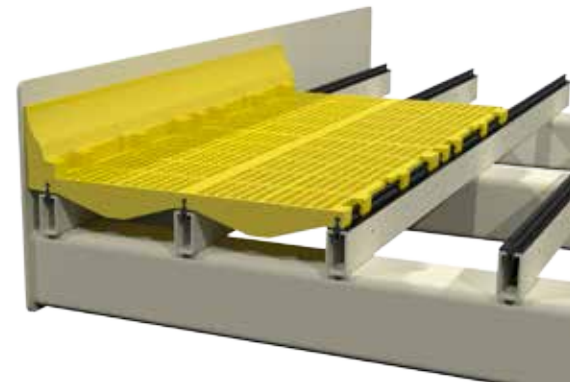
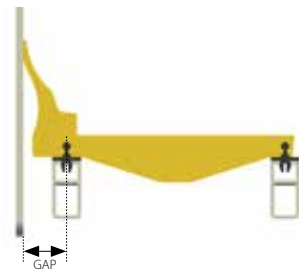

Part No.	Description	Weight (kg)	Liner length (mm)	Gap (mm)	Liner height above deck (mm)		
					BH30	BH40	BH60
MM0428249	LS SL-PU-37-100-500-SNAP-ON	1,5	500	20-32	130	120	100
MM0347135	LS-SL-PU-52-100-500-SNAP ON	2.0	500	35-47	130	120	100
MM0393919	LS-SL-PU-65-100-500-SNAP ON	2.2	500	48-60	130	120	100
MM0393921	LS-SL-PU-78-100-500-SNAP ON	3.1	500	61-73	130	120	100
MM0393922	LS-SL-PU-91-100-500-SNAP ON	3.1	500	74-86	130	120	100
MM0393923	LS-SL-PU-105-100-500-SNAP ON	4.2	500	87-100	130	120	100
MM0428425	LS SL-PU-37-100-610-SNAP-ON	1,8	610	20-32	130	120	100
MM0347137	LS-SL-PU-52-100-610-SNAP ON	2.4	610	35-47	130	120	100
MM0384567	LS-SL-PU-76-100-610-SNAP-ON	3.4	610	48-58	130	120	100
MM0395913	LS-SL-PU-65-100-610-SNAP-ON	2.6	610	48-60	130	120	100
MM0393924	LS-SL-PU-78-100-610-SNAP-ON	3.7	610	61-73	130	120	100
MM0393925	LS-SL-PU-91-100-610-SNAP-ON	3.9	610	74-86	130	120	100
MM0393926	LS-SL-PU-105-100-610-SNAP-ON	5.1	610	87-100	130	120	100
MM0347133	LS-SL-PU-66-150-500-SNAP ON	2.7	500	35-47	180	170	150
MM0347136	LS-SL-PU-66-200-500-SNAP ON	3.5	500	35-47	130	120	200
MM0347137	LS-SL-PU-66-100-610-SNAP ON	2.4	610	35-47	130	120	100
MM0347134	LS-SL-PU-66-150-610-SNAP ON	3.4	610	35-47	180	170	150
MM0384530	LS SL-PU-76-150-610-SNAP-ON	4.7	610	48-58	180	170	150
MM0347138	LS-SL-PU-66-200-610-SNAP ON	4.3	610	35-47	130	120	200

Snap-on discharge module sidewall protection

Part No.	Description	Weight (kg)	Liner length (mm)	Gap* (mm)	Liner height above deck (mm)		
					BH30	BH40	BH60
MM0393927	LS-SL-PU-52-100-500-UGS	2.3	500	35-47	130	120	100
MM0393928	LS-SL-PU-62-100-500-UGS	3.0	500	48-60	130	120	100
MM0393929	LS-SL-PU-78-100-500-UGS	3.9	500	61-73	130	120	100
MM0393930	LS-SL-PU-91-100-500-UGS	4.5	500	74-86	130	120	100
MM0393931	LS-SL-PU-105-100-500-UGS	5.6	500	87-100	130	120	100

Trellex LS – accessories

Ledge angle strips

Developed to suit Metso TS, ES and CVB screens

- Available for all Metso TS screens
- Enables the use of centre modules only, no side modules required



Ledge angle strips for 300LS RU installations on TS screens (SR rail)

Part No.	Description	Length (mm)	Weight (kg)	Module build height (mm)	Screen Model	Strip build height (mm)
MM0352658	LS ACC-PA-5-30-610-20.5	610	0.7	30	TS5.X, TS6.X	5
MM0351381	LS ACC-PA-5-30-500-20.5	500	0.5	30	TS4.X, TS5.X, TS6.X	5
MM0351282	LS ACC-PA-5-40-610-20.5	610	0.8	40	TS5.X, TS6.X	5
MM0351283	LS ACC-PA-5-40-500-20.5	500	0.7	40	TS4.X, TS5.X, TS6.X	5
MM0351279	LS ACC-PA-5-60-610-20.5	610	1.1	60	TS5.X, TS6.X	5
MM0351281	LS ACC-PA-5-60-500-20.5	500	0.9	60	TS4.X, TS5.X, TS6.X	5
MM0352715	LS ACC-PA-5-30-500-15.5	500	0.5	30	TS3.X	5
MM0352716	LS ACC-PA-5-40-500-15.5	500	0.5	40	TS3.X	5
MM0357986	LS ACC-PA-5-60-500-15.5	500	0.7	60	TS3.X	5
MM0363150	LS ACC-PA-5-30-610-13	610	0.5	30	TS2.X	5
MM0365024	LS ACC-PA-5-40-610-13	610	0.6	40	TS2.X	5
MM0365026	LS ACC-PA-5-60-610-13	610	0.8	60	TS2.X	5

Used with 300LS Rubber installations.
For installations with slotted rails.

Ledge Angle Strips for 305LS RU and PU installations on CVB/ES screens (SR rail)

Part No.	Description	Length (mm)	Weight (kg)	Module build height (mm)	Screen Model (CVB/ES)	Strip Build height (mm)
MM0375431	LS ACC-PA-5-30-610-18	610	0.5	30	30X, 40X, 50X, 60X	5
MM0375446	LS ACC-PA-5-40-610-18	610	0.7	40	30X, 40X, 50X, 60X	5
MM0375447	LS ACC-PA-5-60-610-18	610	0.9	60	30X, 40X, 50X, 60X	5

Used with 300LS Rubber installations.
For installations with slotted rails.

Trellex LS – accessories

Ledge angle strips

Developed to suit Metso TS and CVB screens

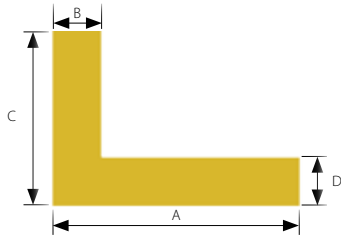
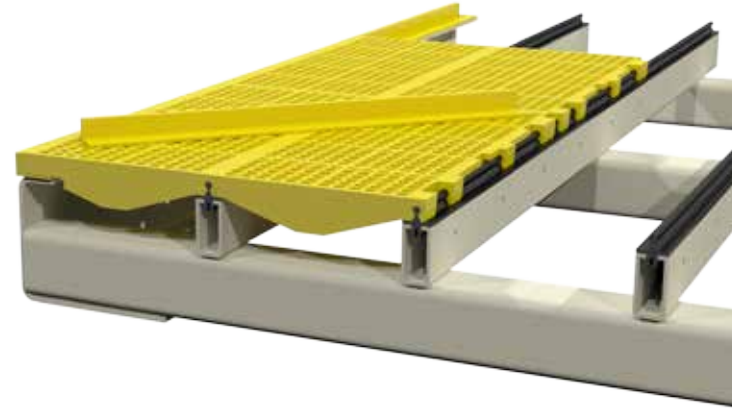

Ledge angle strips for 300LS PU on TS screens (SR rail)

Screen Model	LS Module Height (mm)	Part description	Part No.	Length (mm)	Width A (mm)	Width B (mm)	Height C (mm)	Height D (mm)	Weight (kg)	LS Side module
TS5.X	30	LS ACC-SIDE_STRIP-70/22-34/5-1355	MM0330374	1355	70	22	34	5	1.6	LS-S 300 PU
TS6.X	30	LS ACC-SIDE_STRIP-70/22-34/5-1355	MM0330374	1355	70	22	34	5	1.6	LS-S 300 PU
TS4.X	30	LS ACC-SIDE_STRIP-70/22-34/5-1000	MM0354666	1000	70	22	34	5	1.2	LS-S 300 PU
TS3.X	30	LS ACC-SIDE_STRIP-70/17-34/5-1000	MM0366387	1000	70	17	34	5	1.0	LS-S 300 PU
TS2.X	30	LS ACC-SIDE_STRIP-60/14-34/5-1830	MM0369951	1830	60	14	34	5	1.6	LS-S 300 PU

Ledge angle strips for 300LS PU/RU on CVB screens (SR rail)

Screen Model	LS Module Height (mm)	Part description	Part No.	Length (mm)	Width A (mm)	Width B (mm)	Height C (mm)	Height D (mm)	Weight (kg)	LS Side module
CVB1540	30	LS ACC-SIDE_STRIP-60/8-34/5-1000	MM0350135	1000	60	8	34	5	0.6	LS-S 290
CVB1845	30	LS ACC-SIDE_STRIP-60/8-34/5-1000	MM0350135	1000	60	8	34	5	0.6	LS-S 290
		LS ACC-SIDE_STRIP-60/8-34/5-500	MM0350134	500	60	8	34	5	0.3	
CVB2050	30	LS ACC-SIDE_STRIP-60/8-34/5-1000	MM0350135	1000	60	8	34	5	0.6	LS-S 290 / LS-S 190
CVB2060	30	LS ACC-SIDE_STRIP-60/8-34/5-1000	MM0350135	1000	60	8	34	5	0.6	LS-S 290 / LS-S 190
CVB2661	30	LS ACC-SIDE_STRIP-70/8-34/5-1525	MM0372483	1525	70	8	34	5	1.1	LS-S 290 / LS-S 220
CVB1540	40	LS ACC-SIDE_STRIP-60/8-44/5-1000	ZX11181562	1000	60	8	44	5	0.7	LS-S 290
		LS ACC-SIDE_STRIP-60/8-44/5-1000	ZX11181562	1000	60	8	44	5	0.7	LS-S 290
CVB1845	40	LS ACC-SIDE_STRIP-60/8-44/5-1000	ZX11181562	1000	60	8	44	5	0.7	LS-S 290
		LS ACC-SIDE_STRIP-60/8-44/5-500	MM0350130	500	60	8	44	5	0.4	
CVB2050	40	LS ACC-SIDE_STRIP-60/8-44/5-1000	ZX11181562	1000	60	8	44	5	0.7	LS-S 290 / LS-S 190
CVB2060	40	LS ACC-SIDE_STRIP-60/8-44/5-1000	ZX11181562	1000	60	8	44	5	0.7	LS-S 290 / LS-S 190
CVB2661	40	LS ACC-SIDE_STRIP-70/8-44/5-1525	MM0372492	1525	70	8	44	5	1.2	LS-S 290 / LS-S 220

* For CVB2661 use 6 pcs x 1000mm for each side.
Other dimensions on request.

Trellex LS – accessories

Ledge angle strips

Developed to suit Metso MF, LH and RF screens

Ledge angle strips for 305LS PU/RU (PS rail)

Screen Model	LS Module Height (mm)	Part description	Part No.	Length (mm)	Width A (mm)	Width B (mm)	Height C (mm)	Height D (mm)	Weight (kg)	LS Side module
MF, LH, RF	30	LS ACC-SIDE_STRIP-50/12-40/10-1218	6670924	1218	50	12	40	10	1.3	LS-S 295
		LS ACC-SIDE_STRIP-50/12-40/10-1525	MM0373879	1525	50	12	40	10	1.6	
MF, LH, RF	30	LS ACC-SIDE_STRIP-50/6-40/10-1218	6681643	1218	50	6	40	10	1.0	LS-S 295 with
		LS ACC-SIDE_STRIP-50/6-40/10-1525	MM0373876	1525	50	6	40	10	1.3	6 mm rubber on side
MF, LH, RF	40	LS ACC-SIDE_STRIP-50/12-50/10-1218	6670923	1218	50	12	50	10	1.4	LS-S 295
		LS ACC-SIDE_STRIP-50/12-50/10-1525	MM0373880	1525	50	12	50	10	1.8	
MF, LH, RF	40	LS ACC-SIDE_STRIP-50/6-50/10-1218	MM0373877	1218	50	6	50	10	1.1	LS-S 295 with
		LS ACC-SIDE_STRIP-50/6-50/10-1525	MM0373878	1525	50	6	50	10	1.4	6 mm rubber on side
MF, LH, RF	30	LS ACC-SIDE_STRIP-50/6-40/10-1218	6681643	1218	50	6	40	10	1.0	LS-S 300
		LS ACC-SIDE_STRIP-50/6-40/10-1525	MM0373876	1525	50	6	40	10	1.3	
MF, LH, RF	30	LS ACC-SIDE_STRIP-50/2-40/10-1218	MM0373872	1218	50	2	40	40	0.8	LS-S 300 with
		LS ACC-SIDE_STRIP-50/2-40/10-1525	MM0373873	1525	50	2	40	40	1.0	6 mm rubber on side
MF, LH, RF	40	LS ACC-SIDE_STRIP-50/6-50/10-1218	MM0373877	1218	50	6	50	10	1.1	LS-S 300
		LS ACC-SIDE_STRIP-50/6-50/10-1525	MM0373878	1525	50	6	50	10	1.4	
MF, LH, RF	40	LS ACC-SIDE_STRIP-50/2-50/10-1218	MM0373874	1218	50	2	50	10	0.9	LS-S 300 with
		LS ACC-SIDE_STRIP-50/2-50/10-1525	MM0373875	1525	50	2	50	10	1.1	6 mm rubber on side

Other dimensions on request.



Trellex LS – accessories

Modular discharge lips

Developed to suit mining screens MF, LH, RF etc.

Trellex 305LS modular discharge lips - mining screens (MF, LH, RF)

Part No.	Description	Length x width (mm)	Weight/pcs (kg)	Pins per module intersection (pcs)	305LS Module build height (mm)	Upgrade strip build height (mm)	Discharge lip build height (mm)
MM0361661	305PS-305-35-15-75/80-UNPM-3PIN	305x305	3.3	3	30	5	30+5=35
6620644	305PS-305-35-15-75/80-UNPM-2PIN	305x305	3.3	2	30	5	30+5=35
6620655	305PS 305-45-25-75/80-UNPM-2PIN	305x305	4.5	2	40	5	40+5=45
MM0361660	305PS 305-45-25-75/80-UNPM-3PIN	305x305	4.4	3	40	5	40+5=45
6677170	305PS-305-40-20-75/78-UNPM-2PIN	305x305	3.9	2	30	10	30+10=40
MM0347611	305PS 305-40-20-75/80-UNPM-3PIN	305x305	3.9	3	30	10	30+10=40
MM0341609	305PS 305-50-30-75/78-UNPM-2PIN	305x305	5	2	40	10	40+10=50
MM0344957	305PS 305-50-30-75/78-UNPM-3PIN	305x305	4.9	3	40	10	40+10=50

Part No.	Description	Weight/pcs (kg)
25-380-000-001	Sleeve	0.02
25-380-000-005	Pin - Build height 35/40	0.02
25-380-000-045	Pin - Build height 50	0.05

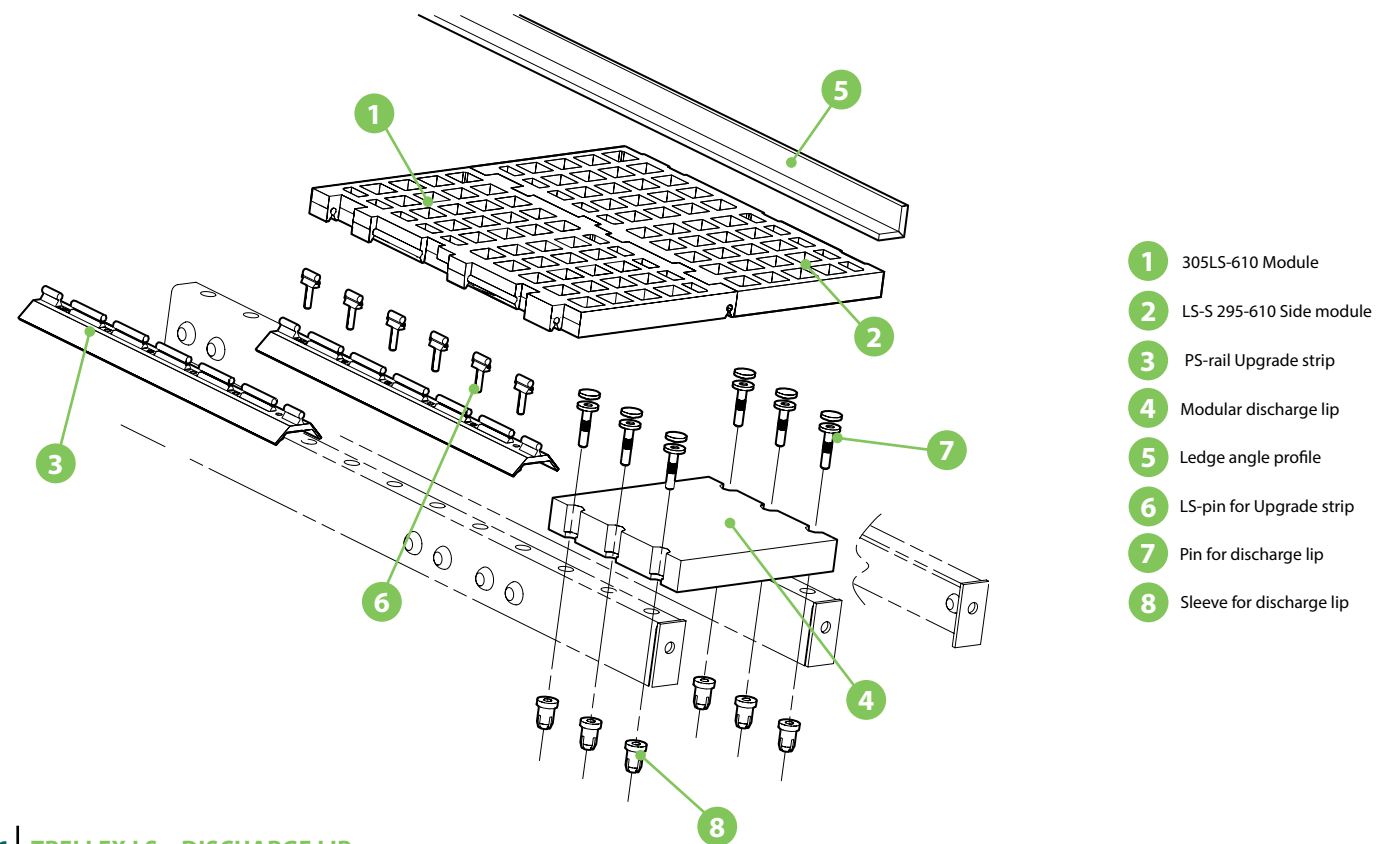

- 1 305LS-610 Module
- 2 LS-S 295-610 Side module
- 3 PS-rail Upgrade strip
- 4 Modular discharge lip
- 5 Ledge angle profile
- 6 LS-pin for Upgrade strip
- 7 Pin for discharge lip
- 8 Sleeve for discharge lip



Trellex LS – accessories

Trellex LS longitudinal rails

Screen modules are mounted on longitudinal rails with upgrade strips. There are various types and designs of rails available – some of the standard installations for Trellex LS are featured here.



LS-SR rails on construction screen

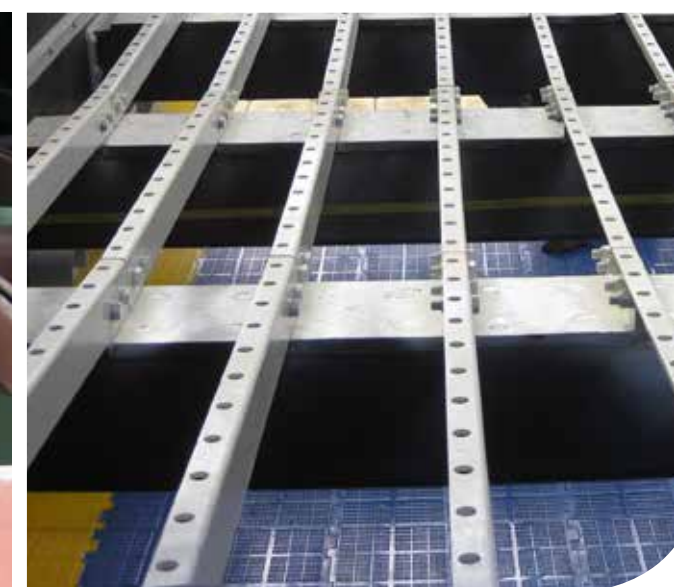

LS-PS rails on mining screen

Trellex LS – accessories

Trellex SR rails

Metso screening media standard rails



Technical details

Section	Rail configurations		
	2020001	6620579	2020003
Data	40x40x5	40x80x5	HD 40x110x5
Steel quality	S355MC	S355MC	S355MC
Weight (kg/m)	4.7	7.81	9.36
Ix (cm ⁴)	11.21	70.16	128.9
Iy (cm ⁴)	13.41	25.74	7.1
Wx (cm ³)	5.2	16.6	21.6
Wy (cm ³)	6.7	12.9	3.6

Maximum length 6100 mm

All rails can be prepared and delivered as custom made parts to suit any screen machine or OEM specification.

We can offer:

- Shot-blasting
- Anti-corrosive paint
- Galvanization
- Drilling
- Welding

Stop plate is essential and required.



Examples of custom made parts

Trellex LS – accessories

Trellex PS rail

Metso screening media standard rail

Technical details

Part No.	Rail configuration
	MM0346840
Dimension (mm)	50x100x8
Rail length	6400 (21')
Steel quality	355MC
Weight (kg/m)	8.62
Ix (cm ⁴)	19.9
Iy (cm ⁴)	113.6
Wx (cm ³)	5.2
Wy (cm ³)	18.1

Rail drilling data	
Hole diameter (mm)	23
Hole quantity (mm)	3 holes/305 (12")
Hole C-C	101.6 (4")

All rails can be prepared and delivered as custom made parts to suit any screen machine or OEM specification.

We can offer:

- Shot-blasting
- Anti-corrosive paint
- Galvanization
- Drilling
- Welding

Stop plate is essential and required.

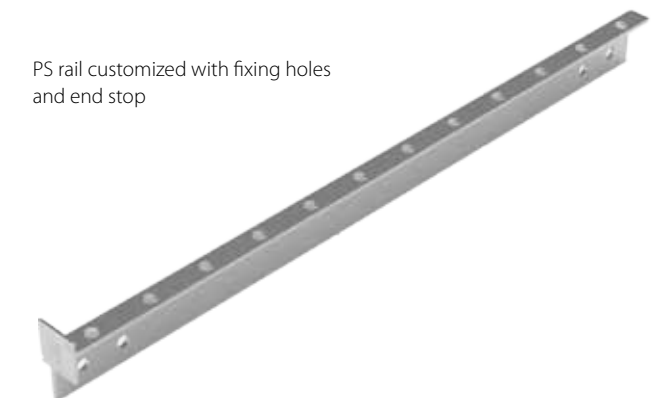
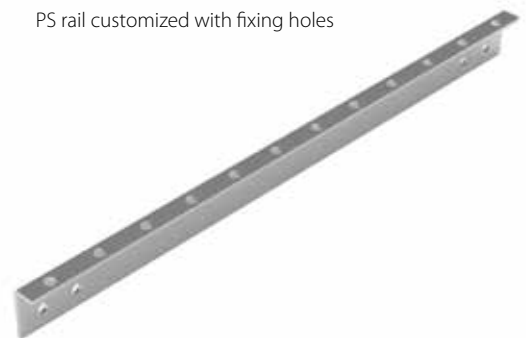
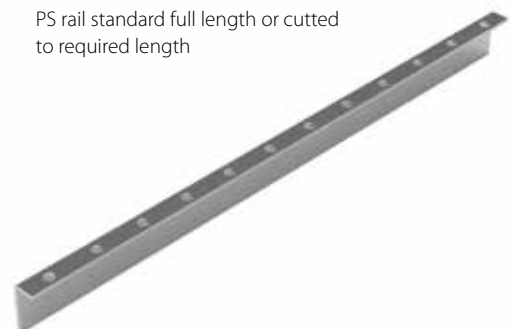
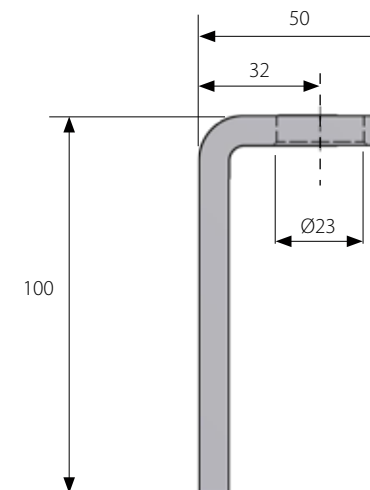

Trellex LS – accessories

Upgrade strips

Upgrade strips are vital to the Trellex LS system. Using them means no drilling, cutting or welding is needed - which simplifies installation significantly.

Choosing the right upgrade strip is also easy, by identifying the existing supports and their design and simply matching up the appropriate version. The Trellex LS system range carries a complete setup of upgrade strips for common longitudinal supports.

The upgrade strips are principally manufactured of ether or PU-quality material. It is chosen for its resistance to the microbiological growths that can occur in some wet applications and cause deteriorating material properties.

Trellex LS – accessories

Upgrade strip Trellex SR rails

- Injection-molded
- Resistant to microbiological growth in environments with process water



Part No.	Description	Weight (kg)	Integrated rail side lining thickness (mm)	Length (mm)	Length (in)	Material
A	6680377.10 LS UGS-SR-500-F (10 pcs)	3.5		500	19.7	TPU (Ether)
A	6680378.10 LS-UGS-SR-610-F (10 pcs)	4		610	24	TPU (Ether)
B	MM0345414-10 LS UGS-SR-500-F-HD-40x80 (10 pcs)	8	5	500	19.7	TPU (Ether)
B	MM0345415-10 LS UGS-SR-610-F-HD-40x80 (10 pcs)	9	5	610	24	TPU (Ether)
C	MM0346453-10 LS UGS-SR-500-F-HD-40x40 (10 pcs)	5	5	500	19.7	TPU (Ether)
C	MM0346452-10 LS UGS-SR-610-F-HD-40x40 (10 pcs)	6	5	610	24	TPU (Ether)

Part No.	Description	Material	Comments
D	MM0358853 LS SR-40-40-PLUG	PU	End plug for slotted rail 40x40
E	MM0358857 LS SR-40-80-PLUG	PU	End plug for slotted rail 40x80

Trellex LS – accessories

Upgrade strip Trellex PS rail

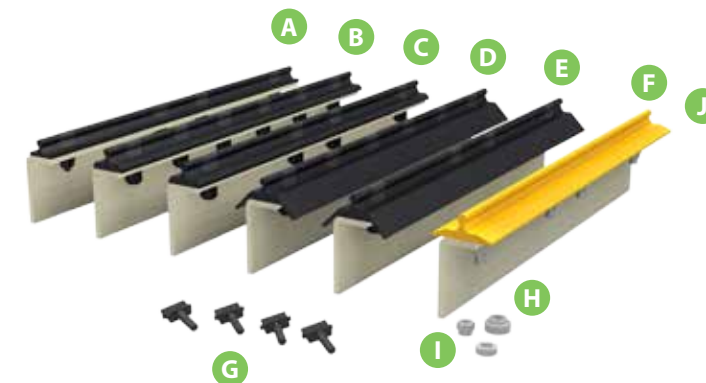

LS-PS Light duty upgrade strip (sleeve expansion)

Part No.	Description	Weight (kg)	Integrated rail side lining	Build Height (mm)	Length (mm)	Length (in)	Material
A	6680423.10** LS UGS-PS-610-F (10PCS+40PINS)	3.60	NO	5	610	24	TPU (Ester)

LS-PS Heavy duty upgrade strip (sleeve expansion)

Part No.	Description	Weight (kg)	Integrated rail side lining	Build Height (mm)	Length (mm)	Length (in)	Material
D	MM0323254-10* LS UGS-PS-610-F-HD-6PIN-CAP (10pcs + 60pins)	6.60	YES	10	610	24	TPU (Ether)
D	MM0361957* LS UGS-PS-305-F-HD-3PIN-CAP	0.30	YES	10	305	12	TPU (Ether)
E	MM0324050-10** LS UGS-PS-610-F-HD-4PIN-CAP (10pcs + 40pins)	6.40	YES	10	610	24	TPU (Ether)
B	MM0324053-10* LS UGS-PS-610-F-HD-6PIN (10pcs + 60pins)	5.60	NO	10	610	24	TPU (Ether)
C	MM0324051-10** LS UGS-PS-610-F-HD-4PIN (10pcs + 40pins)	5.40	NO	10	610	24	TPU (Ether)

* Upgrade strip designed for hole diameter 23mm, pitch 50,8 - 101,6 - 101,6 - 101,6 - 101,6 - 50,8 mm [2"-4"-4"-4"-4"-2"]
 ** Upgrade strip designed for hole diameter 23mm, pitch 50,8 - 203,2 - 101,6 - 203,2 - 50,8 mm [2"-8"-4"-8"-2"]

LS-PS Extra Heavy duty upgrade strips (bolt down)

Part No.	Description	Weight (kg)	Strip Width (mm)	Build Height (mm)	Length (mm)	Length (in)	Material
F	MM0366045*** LS UGS-PS-610-F-XHD-4SCREW-ASSEMBLY	1.90	75	10	610	24	PU Open cast (Ester)
F	MM0367149*** LS UGS-PS-305-F-XHD-2SCREW-ASSEMBLY	0.95	75	10	305	12	PU Open cast (Ester)

These items suits rails with both drilling alternatives specified above.
 *** Article no includes washers & nuts (H,I)

LS-PS Spare parts

Part No.	Description	Material	Remark
G	6680601 LS-PS-UGS-PIN (40pcs)	TPU (Ether)	Spare pins (A-D)
H	MM0367373 LS ACC-WASHER-PS-UGS-XHD	Stainless steel	Spare washer (F)
H	MM0384236 WASHER DIN7989-A12/8-ST-A3A	Zinc coated (FZV)	Alternative washer (F)
I	704203927120 NUT SELF-LOCKING ISO7040-M12-8-A3A	Zinc coated (FZV)	Spare lock nut (F)
J	ZX11233714 LS UGS-PS-610-F-XHD-4SCREW-MATERIAL	PU Open cast (Ester)	Upgrade strip - L=610 (F)
J	ZX11238046 LS UGS-PS-305-F-XHD-2SCREW-MATERIAL	PU Open cast (Ester)	Upgrade strip - L=305 (F)

Trellex LS – accessories

Upgrade strip Trellex PS rail

610LS Coal - Extra Heavy Duty Upgrade Strips (bolt down) - Stud Qty = 6 & 8, continous profile

Part No.	Description	Strip Width (mm)	Build Height (mm)	Length (mm)	Stud quantity* (pcs)	Material
9260010100014	PU -UPGRADESTRIP-1217	100	10	1215	6	PU 95Sh-A (Ester)
ZX11268154	PU -UPGRADESTRIP 1217-15 (6 STUD)	100	15	1215	6	PU 95Sh-A (Ester)
ZX11240831	PU -UPGRADESTRIP-1520 8STUD 10THK	100	10	1520	8	PU 95Sh-A (Ester)
ZX11268155	PU -UPGRADESTRIP 1520-15 (8 STUD)	100	15	1520	8	PU 95Sh-A (Ester)

* 6 stud version = Pitch from end (99) - 303 - 506 - 709,5 - 913 - 1116 [mm]

* 8 stud version = Pitch from end (100) - 305 - 508 - 711 - 914 - 1117 - 1267 - 1470 [mm]

610LS Coal - Extra Heavy Duty Upgrade Strips (bolt down) - Stud Qty = 8 & 10, continous profile

Part No.	Description	Strip Width (mm)	Build Height (mm)	Length (mm)	Stud quantity* (pcs)	Material
ZX11230474	PU -UPGRADESTRIP-1220 8 STUD 10THK	100	10	1215	8	PU 95Sh-A (Ester)
ZX11271163	PU -UPGRADESTRIP 1220-15 (8 STUD 15THK)	100	15	1215	8	PU 95Sh-A (Ester)
ZX11238192	PU -UPGRADESTRIP-1520 10STUD 10THK	100	10	1520	10	PU 95Sh-A (Ester)
ZX11271164	PU -UPGRADESTRIP 1520-15 (10 STUD 15THK)	100	15	1520	10	PU 95Sh-A (Ester)

* 8 stud version = Pitch from end (50.8) - 203.2 - 101.6 - 203.2 - 101.6 - 203.2 [mm]

* 10 stud version = Pitch from end (50.8) - 203.2 - 101.6 - 203.2 - 101.6 - 203.2 - 101.6 - 203.2 - 101.6 - 203.2 [mm]

610LS Coal - Extra Heavy Duty Upgrade Strips (bolt down) - Stud Qty = 6 & 8, Deflector plug “snap-on”

Part No.	Description	Weight (kg)	Strip Width (mm)	Build Height (mm)	Length (mm)	Stud quantity* (pcs)	Plug quantity* (pcs)	Material
ZX11296623	PU UPGRADE STRIP-1220-15	5.3	100	15	1220	6	4	PU 95Sh-A (Ester)
ZX11296624	PU UPGRADE STRIP1520-15 C/W PLUG	7.1	100	15	1520	8	5	PU 95Sh-A (Ester)

* 6 stud version = Pitch from end (99) - 303 - 506 - 709,5 - 913 - 1116 [mm]

* 8 stud version = Pitch from end (100) - 305 - 508 - 711 - 914 - 1117 - 1267 - 1470 [mm]

610LS Coal - Extra Heavy Duty Upgrade Strips (bolt down) - Stud Qty = 8 & 10, Deflector plug “snap-on”

Part No.	Description	Weight (kg)	Strip Width (mm)	Build Height (mm)	Length (mm)	Stud quantity* (pcs)	Plug quantity* (pcs)	Material
ZX11296603	PU UPGRADESTRIP-1215.2-15 (8STUD 4PLUG)@	5.7	100	15	1220	8	4	PU 95Sh-A (Ester)
ZX11296622	PU UPGRADESTRIP 1520-15 W/PLUG@	7.5	100	15	1520	10	5	PU 95Sh-A (Ester)

* 8 stud version = Pitch from end (50.8) - 203.2 - 101.6 - 203.2 - 101.6 - 203.2 [mm]

* 10 stud version = Pitch from end (50.8) - 203.2 - 101.6 - 203.2 - 101.6 - 203.2 - 101.6 - 203.2 - 101.6 - 203.2 [mm]

LS-PS Spare parts

Part No.	Description
ZX11269677	NUT CONELOCK M12
ZX11269811	WASHER CONSTRUCTION M12

Trellex LS – accessories

Upgrade strips - other support profiles

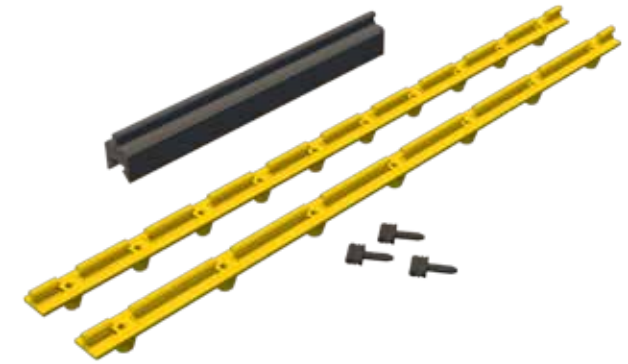

Support profiles, T-Shape 30x8 mm

Part No.	Description	Weight (kg)	Build height (mm)	Length (mm)	Material
6681044	LS ACC-VA FLAT UPGRADE STRIP, L=500	1.10	25	500	PU Open Cast (95Sh-A)
MM0358500	LS ACC-VA FLAT UPGRADE STRIP, L=150	0.33	25	150	PU Open Cast (95Sh-A)

Support profiles, Sleeve expansion - metric installations *

Part No.	Description	Weight (kg)	Build height (mm)	Length (mm)	Material	Quantity sleeves (pcs)	Drilling diameter rail (mm)	Sleeve location (mm)
6680641	LS UGS-PS-1000-F-7-PIN TRELLEX	0.50	5	1000	PU Open Cast (95Sh-A)	7	25	50-6x150-50
6681352	LS UGS-PS-1000-F-10-PIN TRELLEX	0.50	5	1000	PU Open Cast (90Sh-A)	10	23	50-9x100-50

* Before using these items in dewatering screens or other applications with high bed depth - consult technical support.

LS-PS Pins for sleeve expansion

Part No.	Description	Material	Remark
6680601	LS-PS-UGS-PIN (40pcs)	TPU (Ether)	40 pcs



Trellex LS – accessories

Surface features

- Trellex LS Knock-In Deflector - directs the material into screening area

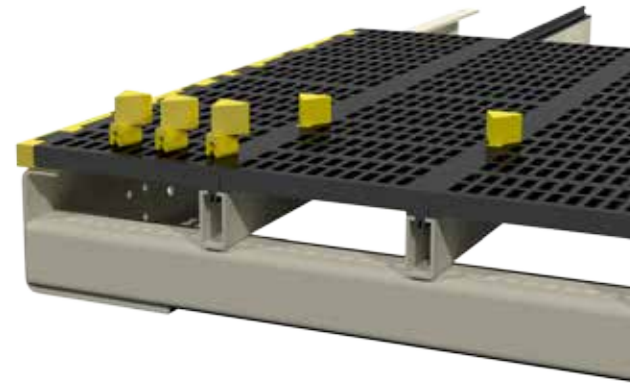

General accessories - 300LS and 305LS

Part No.	Description	Weight (kg)	Module build height (mm)
6680304	LS ACC-KNOCKIN_DEFLECTOR-30	0.10	30
6680331	LS ACC-KNOCKIN_DEFLECTOR-40	0.10	40
6680126	LS ACC-KNOCKIN_DAMBAR_PLUG-21-30	0.02	30
MM0348649	LS ACC-KNOCKIN_DAMBAR_PLUG-21-40	0.03	40
MM0351162	LS ACC-DAMBAR-PLUG-BH30-40 (Full plug)	0.04	30
MM0351152	LS ACC-DAMBAR-PLUG-BH40-40 (Full plug)	0.06	40
2462502	LS ACC PUNCHING TOOL	0.30	n/a

General accessories - 610LS (PU/wedge wire)

Part No.	Description	Weight (kg)	Module build height (mm)
9260010100007	KNOCK-IN DEFLECTOR	0.10	40
9260010100008	DEFLECTOR BLANK PLUG	0.06	40
Part No.	Description	Weight (kg)	Module build height (mm)
ZX11298944	PU DEFLECTOR WITH PLUG-40THICK	0.08	40
ZX11298022	PU 16X40 V PLUG 40MM LONG	0.08	40



Trellex LS – accessories

Surface features

- Trellex LS Knock-In Dambar - for dewatering and wet screening applications

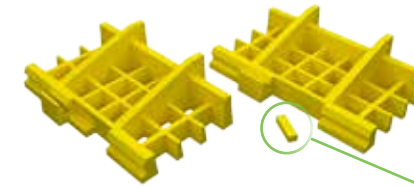

Dam bar plug can be removed from LS module for installation of various accessories. (Punching tool available)



Dam bars 300LS

Part No.	Description	Weight (kg)	Module build height (mm)	Dam bar width (mm)	Dam bar height (mm)	Dam bar location
MM0366330	LS ACC-DAMBAR-300-BH30-40-300	0.90	30	300	40	Centre
MM0366335	LS ACC-DAMBAR-300-BH40-50-300	1.10	40	300	50	Centre
MM0366332	LS ACC-DAMBAR-300-BH30-40-670*	2.40	30	300	40	Side
MM0366336	LS ACC-DAMBAR-300-BH40-50-670*	2.80	40	300	50	Side

* Side dam bar max width = 670 mm, can be cut to any dimension down to 315 mm.

Dam bars 305LS

Part No.	Description	Weight (kg)	Module build height (mm)	Dam bar width (mm)	Dam bar height (mm)	Dam bar location
MM0351168	LS ACC-DAMBAR-305-BH30-40-305	0.90	30	305	40	Centre
MM0351170	LS ACC-DAMBAR-305-BH30-50-305	1.10	30	305	50	Centre
MM0351171	LS ACC-DAMBAR-305-BH30-40-610	1.90	30	610	40	Centre
MM0351169	LS ACC-DAMBAR-305-BH30-50-610	2.20	30	610	50	Centre
MM0351167	LS ACC-DAMBAR-SIDE-305-BH30-40-675*	2.40	30	675	40	Side
MM0351166	LS ACC-DAMBAR-SIDE-305-BH30-50-675*	2.50	30	675	50	Side
MM0351163	LS ACC-DAMBAR-305-BH40-40-305	0.90	40	305	40	Centre
MM0351151	LS ACC-DAMBAR-305-BH40-50-305	1.10	40	305	50	Centre
MM0351164	LS ACC-DAMBAR-305-BH40-40-610	1.90	40	610	40	Centre
MM0351150	LS ACC-DAMBAR-305-BH40-50-610	2.20	40	610	50	Centre
MM0351149	LS ACC-DAMBAR-SIDE-305-BH40-50-675*	2.80	40	675	50	Side
MM0351165	LS ACC-DAMBAR-SIDE-305-BH40-40-675*	2.50	40	675	40	Side

* Side dam bar max width = 675 mm, can be cut to any dimension down to 320 mm.

Dam bars 610LS

Part No.	Description	Module build height (mm)	Dam bar width (mm)	Dam bar height (mm)	Dam bar location
9260010100002	KNOCK-IN DAM BAR - SIDE DAM BAR PU FOR 610 PANELS	40	610	50	Side
9260010100006	KNOCK-IN DAM BAR - CENTER DAM BAR FOR 610 PANELS	40	610	50	Centre
ZX11201326	KNOCK-IN DAM BAR - SIDE DAM BAR PU FOR 711 PANELS	40	711	50	Side
ZX11201327	KNOCK-IN DAM BAR - CENTER DAM BAR FOR 711 PANELS	40	711	50	Centre

Trellex LS – accessories

Trellex ABR - Anti-blinding rods

The Trellex ABR system is a three-armed assembly consisting of polyurethane cylinders connected by an extremely soft ligament. The hard polyurethane cylinder knocks on the screens during operations and together with the soft ligament is maximum movement and flexibility achieved.

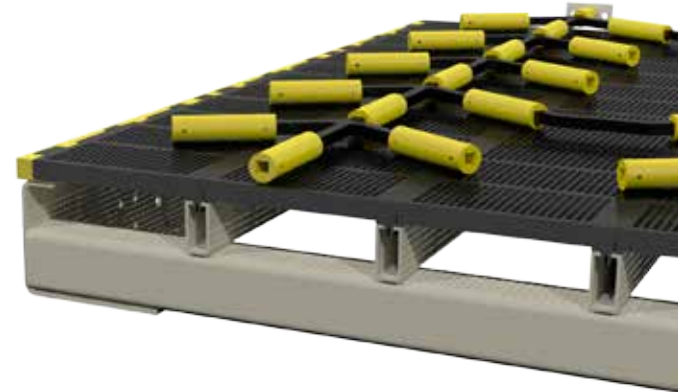

- Trellex ABR prevents your screen deck from blinding and pegging
- Available in standard and light version
 - Standard Version is used with the following media: Polyurethane media, Trellex 60 media and standard woven wire and the Light version is used with: Trellex 40 media and anti-clogging wire (PCL)

Standard version for CVB-screens

Part No.	Description	Unit	Weight (kg/pce)
MM0363806	SM-ACC ABR-STARTPLATE-20x20	pce	0.4
294215	SMS-L ACC NUT NYLOC M12	pce	0.06
MM0364108	SCREW HEX ISO4017-M12X30-8.8-F2J	pce	0.02
MM0363774	SM-ACC PU-STARTCYL-DIA44x83.5	pce	0.1
MM0363903	SCREW HEX ISO4017-M10X60-8.8-F2J	pce	0.05
MM0363838	LOCKNUT. HEXAGONAL. NYLON DIN982-M10-8-F2J	pce	0.01
MM0363899	PARALLEL PIN ISO8734-10X45-B-ST-UNPLTD	pce	0.03
MM0362657	SM-ACC ABR-3-ARM-KIT-20x20	pce	0.9
MM0362655	SM-ACC ABR-3-ARM-LINK-20x20	pce	0.1

Screen models/Quantities/Kit assembly codes

CVB1540 N92340704	CVB1845 N92340702	CVB2050 N92340701	CVB2060 N92340700	CVB2661 N92340705
2	3	3	3	4
4	6	6	6	8
4	6	6	6	8
2	3	3	3	4
2	3	3	3	4
2	3	3	3	4
22	35	42	45	68
20	33	39	45	64
		2	2	2

Standard version for TS-screens

Part No.	Description	Unit	Weight (kg/pce)
MM0363806	SM-ACC ABR-STARTPLATE-20x20	pce	0.4
294215	SMS-L ACC NUT NYLOC M12	pce	0.06
MM0364108	SCREW HEX ISO4017-M12X30-8.8-F2J	pce	0.02
MM0363774	SM-ACC PU-STARTCYL-DIA44x83.5	pce	0.1
MM0363903	SCREW HEX ISO4017-M10X60-8.8-F2J	pce	0.05
MM0363838	LOCKNUT. HEXAGONAL. NYLON DIN982-M10-8-F2J	pce	0.01
MM0363899	PARALLEL PIN ISO8734-10X45-B-ST-UNPLTD	pce	0.03
MM0362657	SM-ACC ABR-3-ARM-KIT-20x20	pce	0.9
MM0362655	SM-ACC ABR-3-ARM-LINK-20x20	pce	0.1

Screen models/Quantities/Kit assembly codes

TS2.X N92343805	TS3.X N92343806	TS4.X N92343807	TS5.X N92343808	TS6.X N92343809
2	3	4	4	4
4	6	8	8	8
4	6	8	8	8
2	3	4	4	4
2	3	4	4	4
2	3	4	4	5
35	52	71	93	93
28	45	60	84	84
2	2	2	2	2

Light version for CVB-screens

Part No.	Description	Unit	Weight (kg/pce)
MM0363806	SM-ACC ABR-STARTPLATE-20x20	pce	0.4
294215	SMS-L ACC NUT NYLOC M12	pce	0.06
MM0364108	SCREW HEX ISO4017-M12X30-8.8-F2J	pce	0.02
MM0363789	SM-ACC PU-STARTCYL-DIA44x83.5	pce	0.1
MM0363903	SCREW HEX ISO4017-M10X60-8.8-F2J	pce	0.05
MM0363838	LOCKNUT. HEXAGONAL. NYLON DIN982-M10-8-F2J	pce	0.01
MM0363435	PARALLEL PIN ISO8734-6X32-A-ST-UNPLTD	pce	0.1
MM0362644	SM-ACC ABR-3-ARM-KIT-15x15	pce	0.6
MM0362580	SM-ACC ABR-3-ARM-LINK-15x15	pce	0.1

Screen models/Quantities/Kit assembly codes

CVB1540 MM0369971	CVB1845 MM0369972	CVB2050 MM0369973	CVB2060 N92340706	CVB2661 MM0369974
2	3	3	3	4
4	6	6	6	8
4	6	6	6	8
2	3	3	3	4
2	3	3	3	4
2	3	3	3	4
22	35	42	45	68
20	33	39	45	64
		2	2	2

Light version for TS-screens

Part No.	Description	Unit	Weight (kg/pce)
MM0363806	SM-ACC ABR-STARTPLATE-20x20	pce	0.4
294215	SMS-L ACC NUT NYLOC M12	pce	0.06
MM0364108	SCREW HEX ISO4017-M12X30-8.8-F2J	pce	0.02
MM0363789	SM-ACC PU-STARTCYL-DIA44x83.5	pce	0.1
MM0363903	SCREW HEX ISO4017-M10X60-8.8-F2J	pce	0.05
MM0363838	LOCKNUT. HEXAGONAL. NYLON DIN982-M10-8-F2J	pce	0.01
MM0363435	PARALLEL PIN ISO8734-6X32-A-ST-UNPLTD	pce	0.1
MM0362644	SM-ACC ABR-3-ARM-KIT-15x15	pce	0.6
MM0362580	SM-ACC ABR-3-ARM-LINK-15x15	pce	0.1

Screen models/Quantities/Kit assembly codes

TS2.X MM0366239	TS3.X N92343819	TS4.X N92343818	TS5.X N92343820	TS6.X MM0366240
2	3	4	4	4
4	6	8	8	8
4	6	8	8	8
2	3	4	4	4
2	3	4	4	4
2	3	4	4	4
35	52	71	93	93
28	45	60	84	84
2	2	2	2	2



Trellex LS – accessories

Continued from previous page

Standard version for CVB/ES 20X, 30X, 40X and 50X

Part No.	Description	Unit	Weight (kg/pce)
MM0363806	SM-ACC ABR-STARTPLATE-20x20	pce	0.4
294215	SMS-L ACC Nut Nyloc M12	pce	0.06
MM0364108	SCREW, HEXAGONAL ISO4017-M12X30-8.8-F2J	pce	0.02
MM0363774	SM-ACC ABR-PU-STARTCYL-DIA44x83,5	pce	0.1
MM0363903	SCREW, HEXAGONAL ISO4017-M10X60-8.8-F2J	pce	0.05
MM0363838	LOCKNUT HEX, NYL DIN982-M10-8-F2J	pce	0.01
MM0363899	PIN, PARALLEL ISO8734-10X45-B-ST-UNPLTD	pce	0.03
MM0362657	SM-ACC ABR-3-ARM-KIT-20x20	pce	0.9
MM0362655	SM-ACC ABR-3-ARM-LINK-20x20	pce	0.1

Light version for CVB/ES 20X, 30X, 40X and 50X

Part No.	Description	Unit	Weight (kg/pce)
MM0363806	SM-ACC ABR-STARTPLATE-20x20	pce	0.4
294215	SMS-L ACC Nut Nyloc M12	pce	0.06
MM0364108	SCREW, HEXAGONAL ISO4017-M12X30-8.8-F2J	pce	0.02
MM0363789	SM-ACC ABR-PU-STARTCYL-DIA35x83,5	pce	0.1
MM0363903	SCREW, HEXAGONAL ISO4017-M10X60-8.8-F2J	pce	0.05
MM0363838	LOCKNUT HEX, NYL DIN982-M10-8-F2J	pce	0.01
MM0363435	PIN, PARALLEL ISO8734-6X32-A-ST-UNPLTD	pce	0.1
MM0362644	SM-ACC ABR-3-ARM-KIT-15x15	pce	0.6
MM0362580	SM-ACC ABR-3-ARM-LINK	pce	0.1

Screen models/Quantities/ Kit assembly codes - Standard

MM0426450 CVB 10X	MM0426449 CVB/ES 20X	MM0384593 CVB/ES 30X	MM0384612 CVB/ES 40X	MM0413584 CVB50X	MM0426448 CVB 60X
2	3	3	4	4	4
4	6	6	8	8	8
4	6	6	8	8	8
2	3	3	4	4	4
2	3	3	4	4	4
2	3	3	4	4	4
20	39	45	68	84	84
18	36	45	64	80	80
		2	2	2	2

Screen models/Quantities/ Kit assembly codes - Light

MM0426456 CVB 10X	MM0426454 CVB/ES 20X	MM0384608 CVB/ES 30X	MM0384614 CVB/ES 40X	MM0413586 CVB50X	MM0426452 CVB 60X
2	3	3	4	4	4
4	6	6	8	8	8
4	6	6	8	8	8
2	3	3	4	4	4
2	3	3	4	4	4
2	3	3	4	4	4
20	39	45	68	84	84
18	36	45	64	80	80
		2	2	2	2

Trellex LS – accessories

Trellex ABR - components

Feed End Attachments

Item	Part No.	Description	Remark	Unit	Weight (kg)
1	MM0363806	SM-ACC ABR-STARTPLATE-20x20	Start Plate CVB/TS/FS	pce	0.4
2	294215	SMS-L ACC NUT NYLOC M12	Nut for startplate	pce	0.06
3	MM0364108	SCREW HEX ISO4017-M12X30-8.8-F2J	Bolt for start plate	pce	0.02
4	MM0363774	SM-ACC PU-STARTCYL-DIA44x83.5	Connection Standard	pce	0.1
5	MM0363789	SM-ACC PU-STARTCYL-DIA44x83.5	Connection Light	pce	0.1
6	MM0363903	SCREW HEX ISO4017-M10X60-8.8-F2J	Bolt for startcyl	pce	0.05
7	MM0363838	LOCKNUT. HEXAGONAL. NYLON DIN982-M10-8-F2J	Nut for startcyl	pce	0.01

Standard Assemblies

Item	Part No.	Description	Remark	Unit	Weight (kg)
8	MM0363899	PARALLEL PIN ISO8734-10X45-B-ST-UNPLTD	Pin for standard assembly	pce	0.03
9	MM0362657	SM-ACC ABR-3-ARM-KIT-20x20	Standard 3-arm	pce	0.9
10	MM0362655	SM-ACC ABR-3-ARM-LINK-20x20	Cross link - standard	pce	0.1

Light Assemblies

Item	Part No.	Description	Remark	Unit	Weight (kg)
11	MM0363435	PARALLEL PIN ISO8734-6X32-A-ST-UNPLTD	Pin for light assembly	pce	0.1
12	MM0362644	SM-ACC ABR-3-ARM-KIT-15x15	Light 3-arm	pce	0.6
13	MM0362580	SM-ACC ABR-3-ARM-LINK-15x15	Cross link - light	pce	0.1

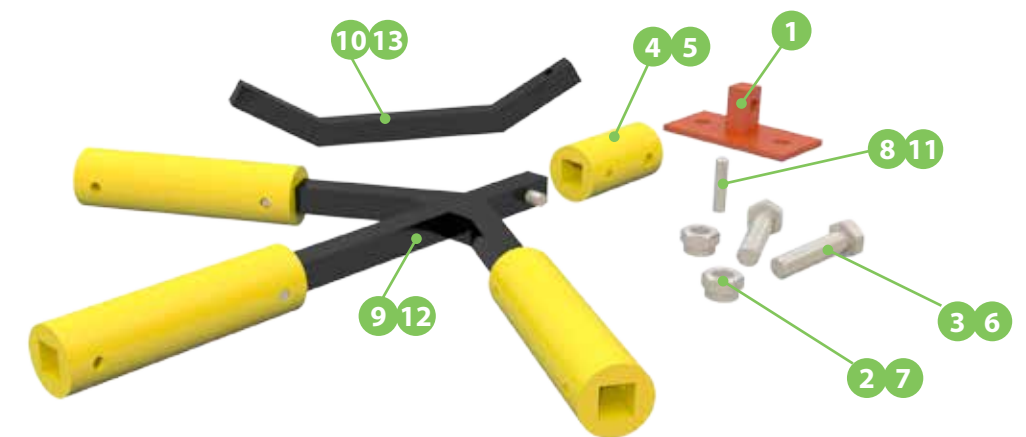

Trellex LS – accessories

Trellex LS wire insert - SR rails

■ Used when mixing synthetic and wire media

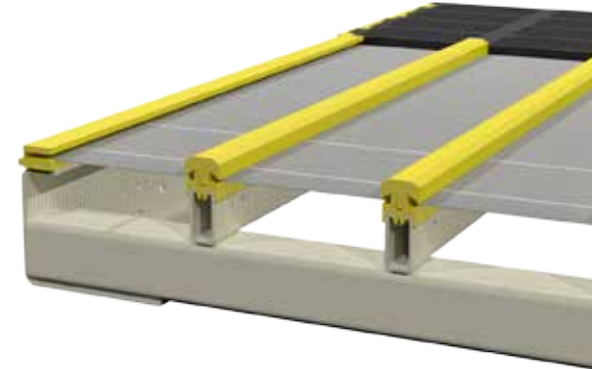

LS WI-SR Wire insert profile

Part No.	Description	Weight (kg)	Length (mm)
6680620	LS-WI-SR-1220-B10	1.5	1220
6670856	LS-WI-SR-1000-B10	1.2	1000
6680907	LS-WI-SR-1000-B15	1.4	1000
6680908	LS-WI-SR-1220-B15	1.7	1220
6680909	LS-WI-SR-1000-TOP	1.7	1000
6680910	LS-WI-SR-1220-TOP	2.1	1220

LS WI-SR Wire side strip for sideliners with wedge

Part No.	Description	Weight (kg)	Dimension (mm)
6670884	LS-WI-SIDE-STRIP-60/15-5-1000	1.9	60/15-5-1000
MM0323362	LS-WI-SIDE-STRIP-60/15-5-1220	2.4	60/15-5-1220
6670885	LS-WI-SIDE-STRIP-60/15-10-1000	1.7	60/15-10-1000
MM0323359	LS-WI-SIDE-STRIP-60/15-10-1220	2.0	60/15-10-1220
MM0359240	LS-WI-SIDE-STRIP-60/10-15-1000	1.7	60/10-15-1000
MM0349988	LS-WI-SIDE-STRIP-60/10-15-1220	2.0	60/10-15-1220

LS WI-SR Wire side strip for sideliners with groove

Part No.	Description	Weight (kg)	Dimension (mm)
MM0349103	LS-WI-BG-STRIP-30/15-5-1000	0.9	30/15-5-1000
MM0349097	LS-WI-BG-STRIP-30/15-5-1219	1.1	30/15-5-1219
MM0349101	LS-WI-BG-STRIP-30/15-8-1000	0.8	30/15-8-1000
MM0349102	LS-WI-BG-STRIP-30/15-8-1219	1.0	30/15-8-1219
MM0349098	LS-WI-BG-STRIP-30/15-10-1000	0.8	30/15-10-1000
MM0349100	LS-WI-BG-STRIP-30/15-10-1219	1.0	30/15-10-1219

Note: Only for SR rails



Trellex LS – accessories

Trellex LS wire insert - PS rails

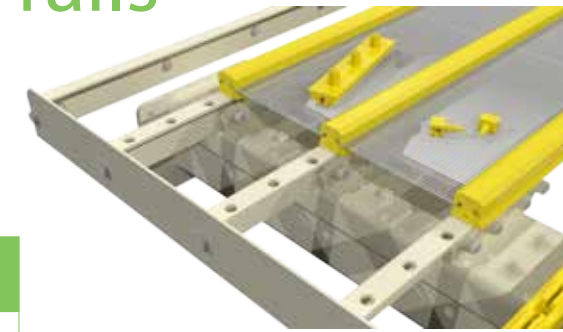

LS WI-PS-Standard (sleeve expansion)

Part No.	Description	Weight (kg)	Pin requirement (qty)	Build height (mm)	Length (mm)	Material
MM0380972	LS WI-PS-610-B15-6PIN (Excluding Pins)	0.70	6	15	610	PU 95Sh-A
MM0380977	LS WI-PS-305-B15-3PIN (Excluding Pins)	0.40	3	15	305	PU 95Sh-A
MM0380979	LS WI-PS-610-B20-6PIN (Excluding Pins)	0.80	6	20	610	PU 95Sh-A
MM0380980	LS WI-PS-305-B20-3PIN (Excluding Pins)	0.40	3	20	305	PU 95Sh-A

* Strips designed for hole diameter 23mm, pitch 50.8 - 101.6 - 101.6 - 101.6 - 101.6 - 50.8 mm [2"-4"-4"-4"-4"-2"]

LS WI-PS Accessories

Part No.	Description	Material	Remark
MM0384952	LS PIN FOR LS WIRE PS RAIL	PU 65Sh-D	Sleeve expansion pin
MM0384236	WASHER DIN7989-A12/8-ST-A3A	Zinc coated (FZV)	Spare washer
704203927120	NUT SELF-LOCKING ISO7040-M12-8-A3A	Zinc coated (FZV)	Spare lock nut

LS WI-PS Wire side strip for side liners with wedge

Part No.	Description	Weight (kg)	Length (mm)	Build height (mm)	Max clamping
MM0382715	LS ACC-LS-WI-SIDE-STRIP-50/20-5-1219	1.90	1219	20	5
MM0382805	LS ACC-LS-WI-SIDE-STRIP-50/20-5-1525	2.40	1525	20	5
MM0382817	LS ACC-LS-WI-SIDE-STRIP-50/20-10-1219	1.60	1219	20	10
MM0382819	LS ACC-LS-WI-SIDE-STRIP-50/20-10-1525	2.00	1525	20	10
MM0382821	LS ACC-LS-WI-SIDE-STRIP-50/15-15-1219	1.40	1219	15	15
MM0382822	LS ACC-LS-WI-SIDE-STRIP-50/15-15-1525	1.70	1525	15	15

LS WI-TOP Locking strips

Part No.	Description	Weight (kg)	Length (mm)	Material
6680910	LS WI-SR-1220-TOP	2.10	1220	PU 90Sh-A
MM0359218	LS WI-SR-610-TOP	1.05	610	PU 90Sh-A
MM0395418	LS WI-SR-305-TOP	0.50	305	PU 90Sh-A

Trellex LS – accessories

Trellex LS wire insert - PS rails

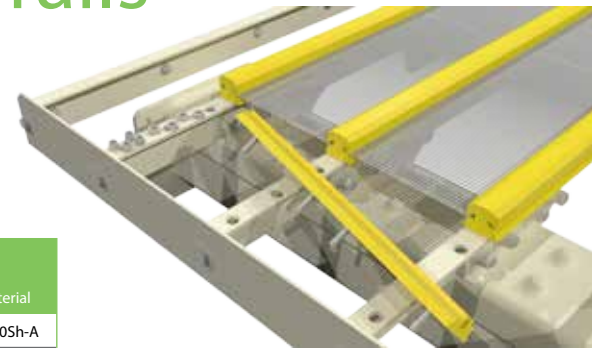

LS WI-PS-Extra heavy duty (bolt down)

Part No.	Description	Weight (kg)	Bolts (qty)	Build height (mm)	Length (mm)	Material
MM0399229	LS WI-PS-610-B20-XHD-4SCREW-ASSEMBLY*)	2.10	4	20	610	PU 90Sh-A
MM0399231	LS WI-PS-305-B20-XHD-2SCREW-ASSEMBLY*)	0.90	4	20	305	PU 90Sh-A
MM0416236	LS WI-PS-610-B20-XHD-3SCREW-ASSEMBLY***)	2.00	3	20	610	PU 90Sh-A

* Strips designed for hole diameter 23mm, pitch 50.8 - 101.6 - 101.6 - 101.6 - 101.6 - 50.8 mm [2"-4"-4"-4"-4"-2"] as well as hole diameter 23mm, pitch 50.8 - 203.8 - 101.6 - 203.2 - 50.8 mm [2"-8"-4"-8"-2"]

** Assembly includes lock nuts + washers

*** Strips designed for hole diameter 23mm, pitch 50,8 - 203,2 - 203,2 - 50,8 mm [2"-8"-8"-2"]

LS WI-PS Accessories

Part No.	Description	Material	Remark
MM0384952	LS PIN FOR LS WIRE PS RAIL	PU 65Sh-D	Sleeve expansion pin
MM0384236	WASHER DIN7989-A12/8-ST-A3A	Zinc coated (FZV)	Spare washer
704203927120	NUT SELF-LOCKING ISO7040-M12-8-A3A	Zinc coated (FZV)	Spare lock nut

LS WI-PS Wire side strip for side liners with wedge

Part No.	Description	Weight (kg)	Length (mm)	Build height (mm)	Max clamping
MM0382715	LS ACC-LS-WI-SIDE-STRIP-50/20-5-1219	1.90	1219	20	5
MM0382805	LS ACC-LS-WI-SIDE-STRIP-50/20-5-1525	2.40	1525	20	5
MM0382817	LS ACC-LS-WI-SIDE-STRIP-50/20-10-1219	1.60	1219	20	10
MM0382819	LS ACC-LS-WI-SIDE-STRIP-50/20-10-1525	2.00	1525	20	10
MM0382821	LS ACC-LS-WI-SIDE-STRIP-50/15-15-1219	1.40	1219	15	15
MM0382822	LS ACC-LS-WI-SIDE-STRIP-50/15-15-1525	1.70	1525	15	15

LS WI-TOP Locking strips

Part No.	Description	Weight (kg)	Length (mm)	Material
6680910	LS WI-SR-1220-TOP	2.10	1220	PU 90Sh-A
MM0359218	LS WI-SR-610-TOP	1.05	610	PU 90Sh-A
MM0395418	LS WI-SR-305-TOP	0.50	305	PU 90Sh-A

Trellex LS modular system

Trellex LS installation

Installation of Trellex LS modular system is optimized for shortest possible downtime. Shown below is a screen deck prepared with slotted rails bolted to crossmembers. The next step in the installation procedure is to knock in the corresponding upgrade strip. The final step is to install the modules by snap-on, i.e no bolts or pins, etc.



Trellex LS – installation

Installation of Trellex LS on SR rails

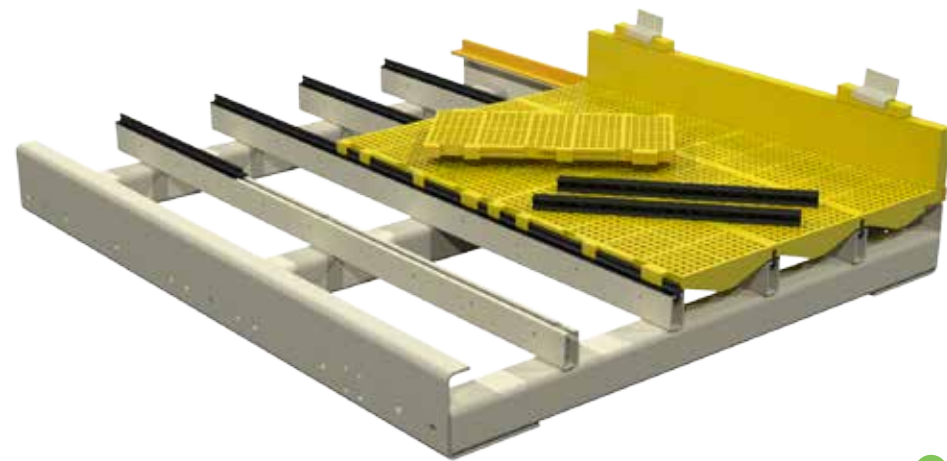

- A** Wedge
 - B** Sideline
 - C** SR rail (40x80)
 - D** Side wall of the screening machine
 - E** Ledge angle
 - F** LS-S side module
 - G** Upgrade strip, LS-UGS-SR
 - H** LS centre module
 - I** Ledge angle profile
- SMW Side module width
BH Module build height

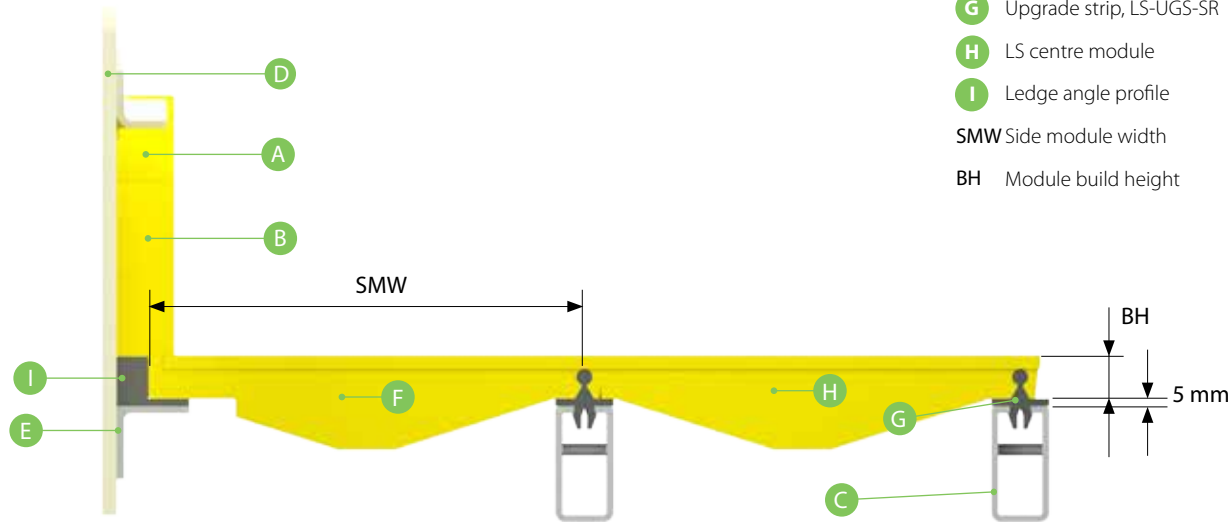

Trellex LS – installation

Installation of Trellex LS on PS-rail

With sleeve expansion locking

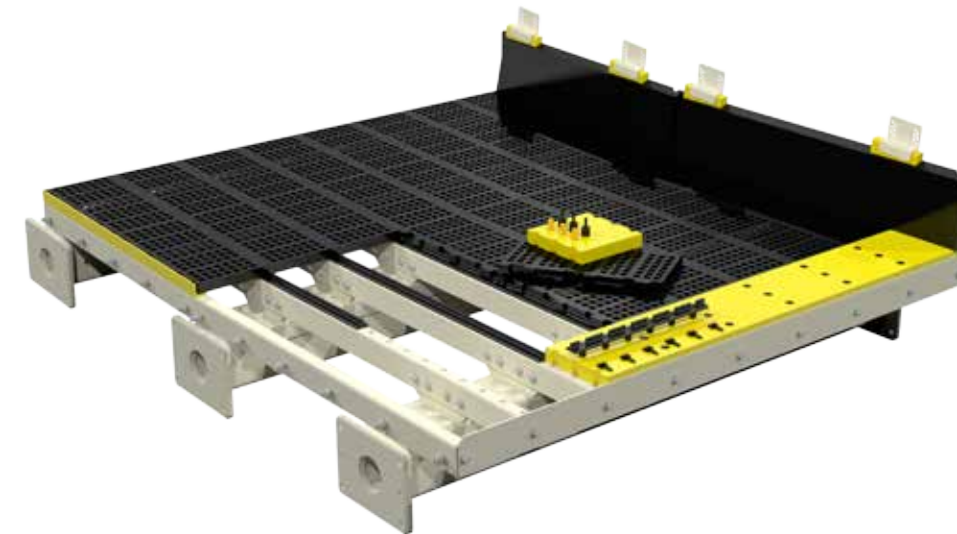

- A** Wedge
 - B** Sideline
 - C** PS rail, drilled for pin and sleeve
 - D** Side wall of the screening machine
 - E** Ledge angle
 - F** LS-S side module
 - G** Upgrade strip, LS-UGS-PS
 - H** LS centre module
 - I** Ledge angle profile
- SMW Side module width
BH Module build height

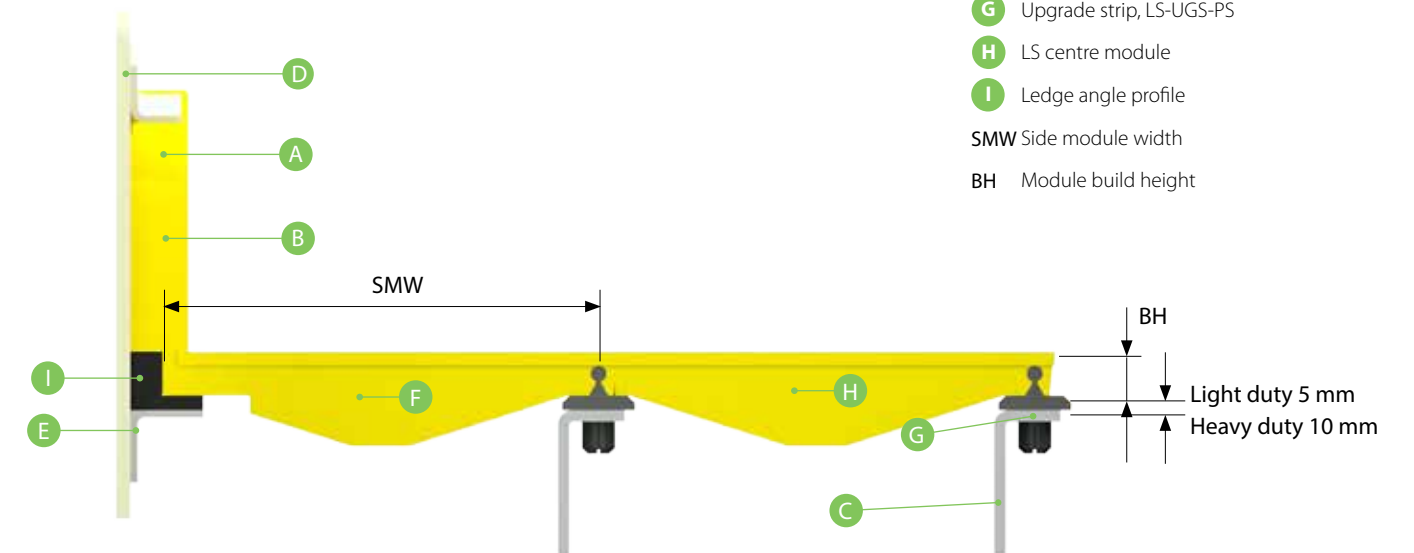

Trellex LS – installation

Installation guidelines

LS Module screen deck

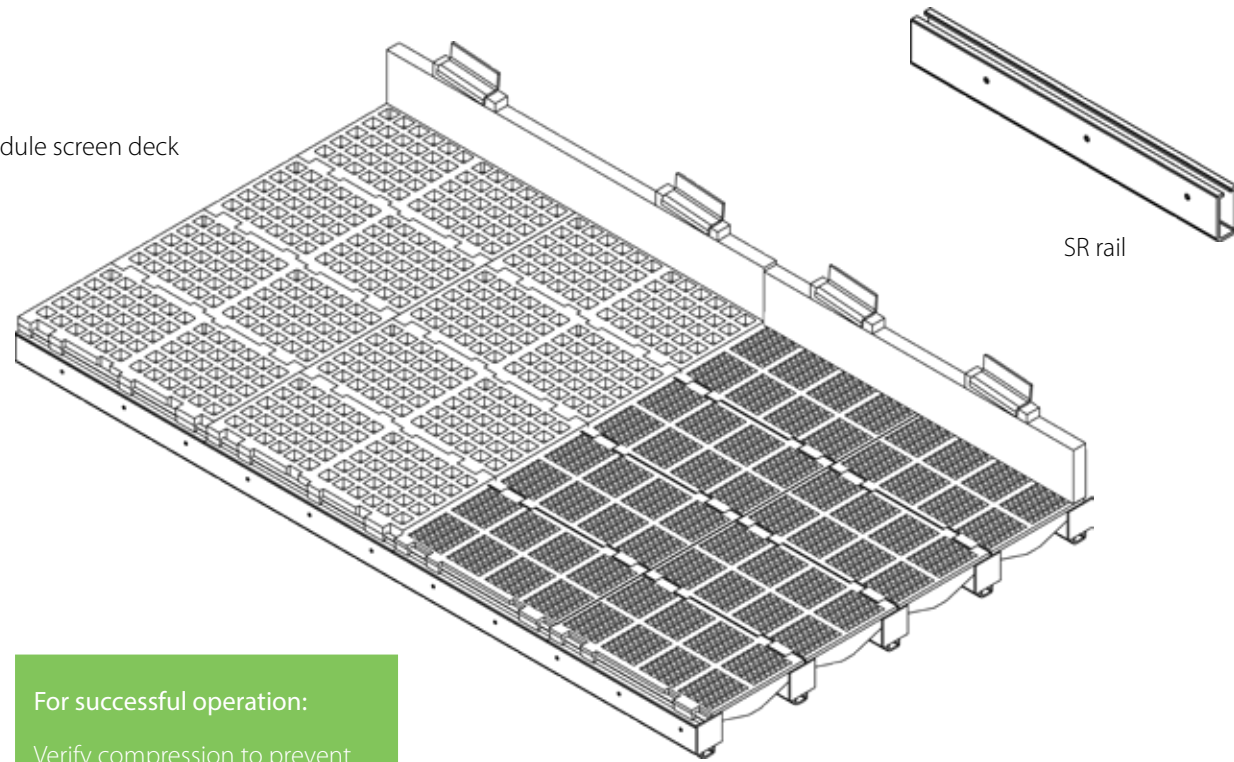

SR rail

For successful operation:

Verify compression to prevent movement of modules.
End stops are required.

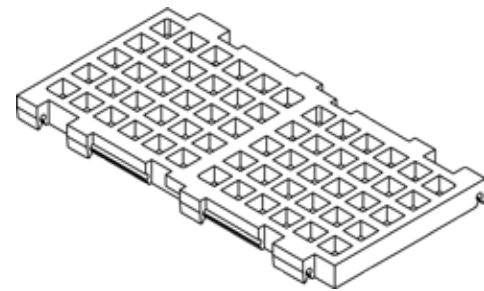

LS module

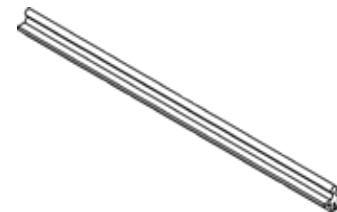

SR upgrade strip

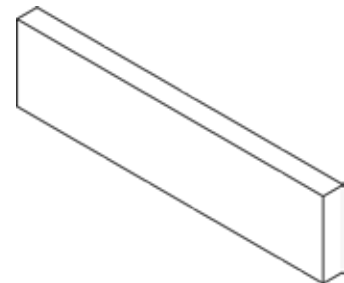

Sideline

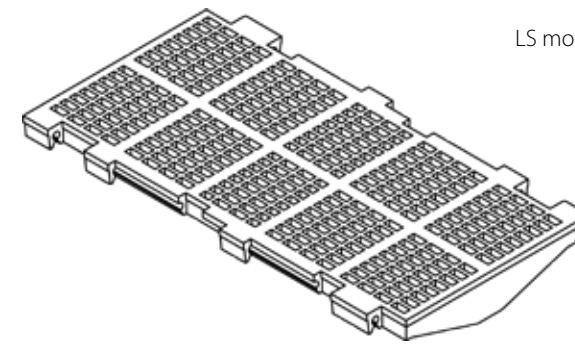

LS module - Polyurethane

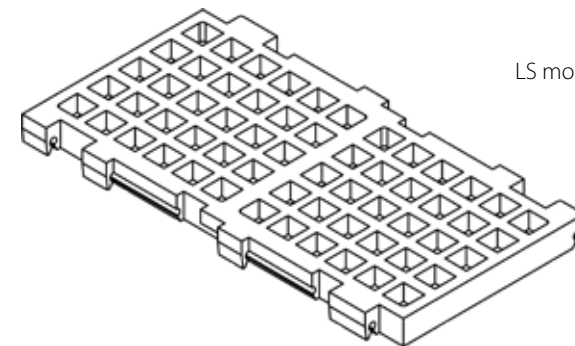
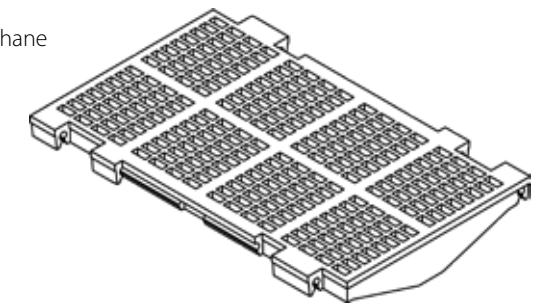

LS module - Rubber

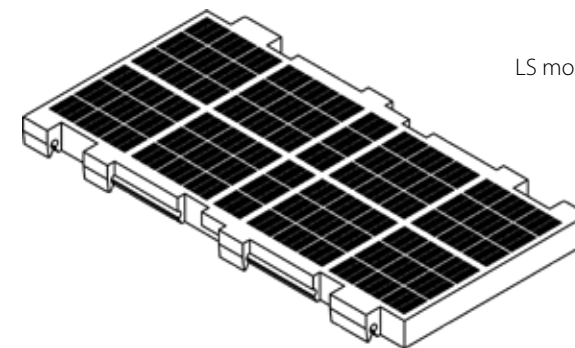
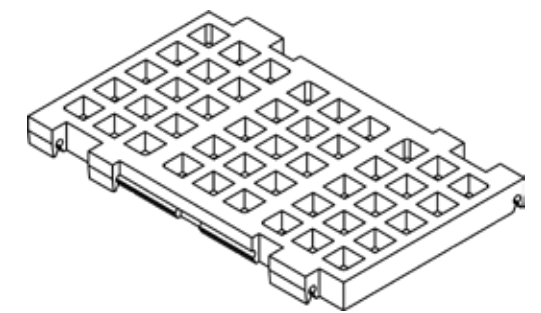

LS module - TPU

Trellex LS – installation

Installation of LS modules

- 1 Verify C-C distance between rails and begin the installation of modules at the feed end.
- 2 Apply soap and water mix on the upgrade strips and corresponding areas on LS-module.
- 3 Begin installation of LS modules in the feed end of the screen. Work from the middle towards the side walls.
- 4 Modules can be installed "one at a time" or simultaneously as shown by figure (/\) if the compression is tight.
- 5 For successful operation, verify/assure compression in all directions to prevent movement of modules.

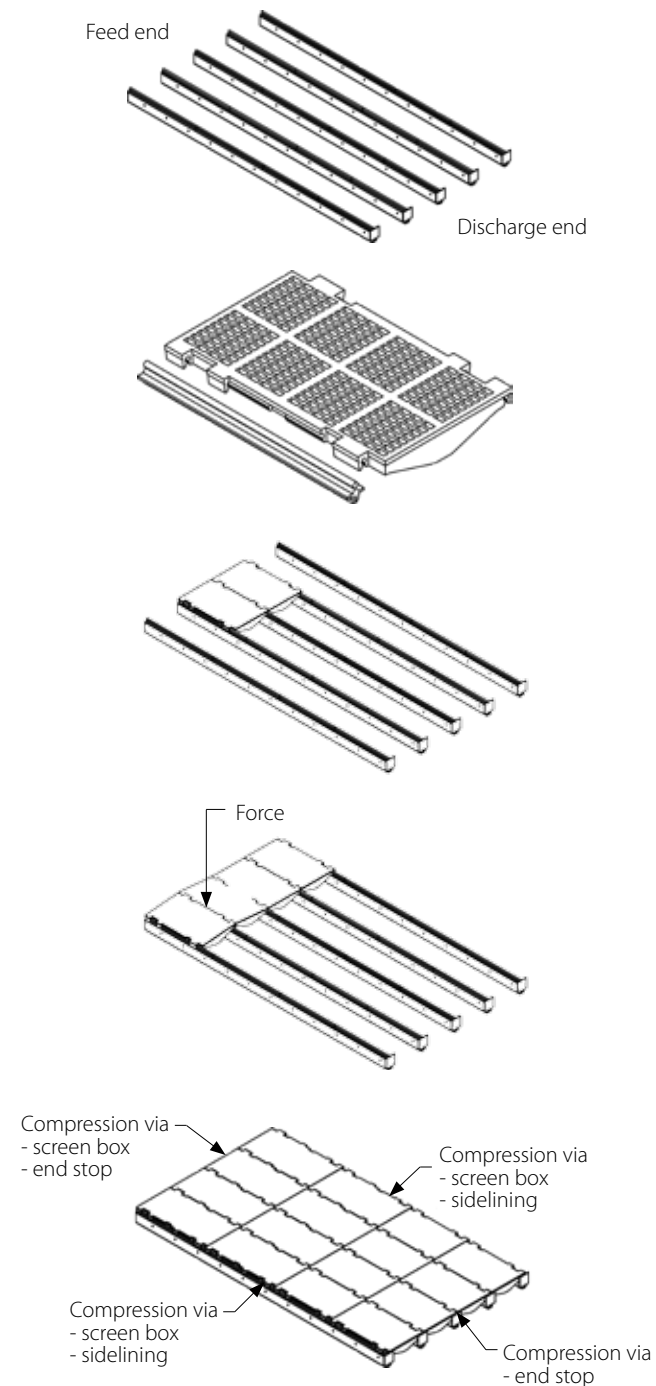

Trellex LS – installation

Installation of upgrade strips in SR rails

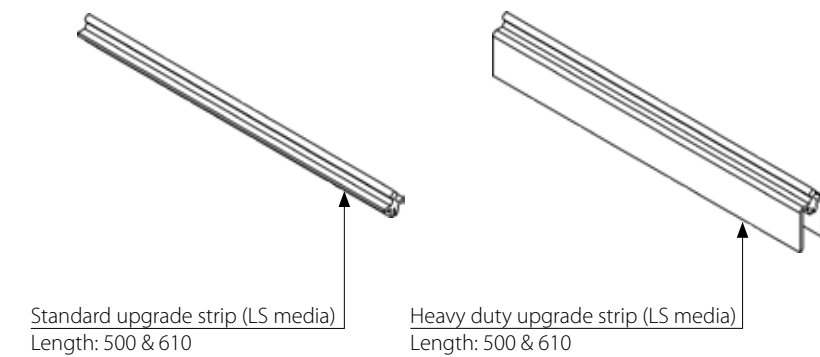

Equipment

- Sledge hammer (2 kg +)
- Soap and water mix (no other lubricant allowed)

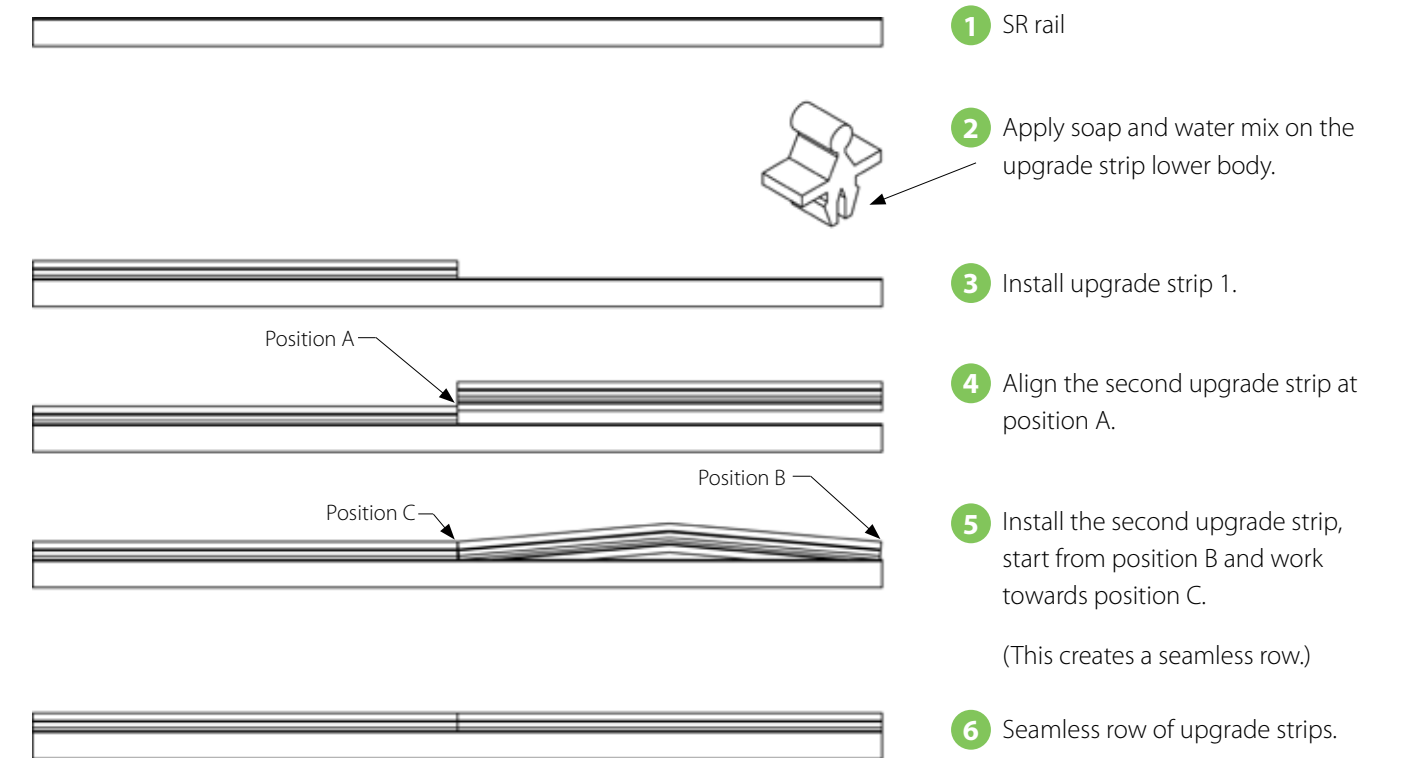

Trellex LS – installation

Installation of upgrade strips on PS rail

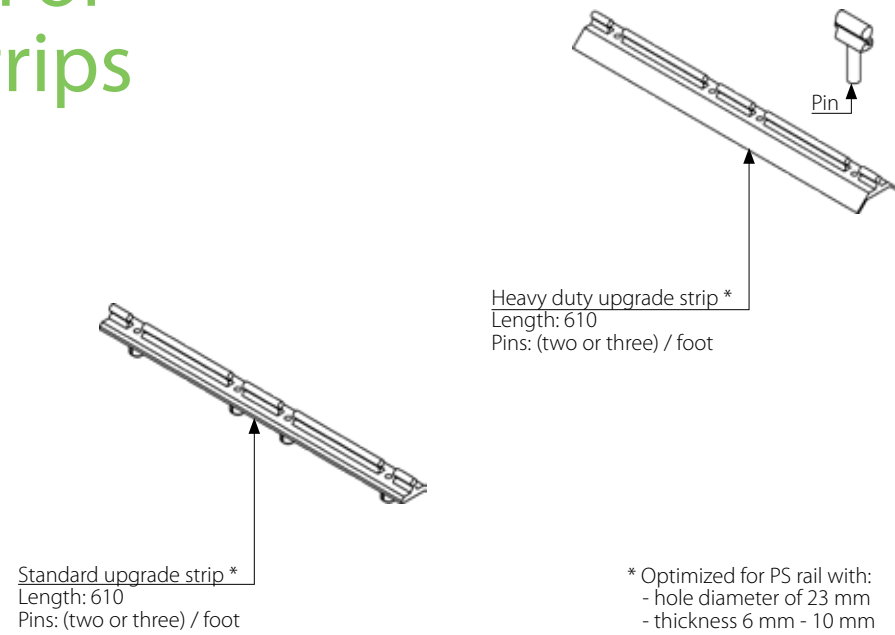

Equipment

- Sledge hammer (2 kg +)
- Universal pliers

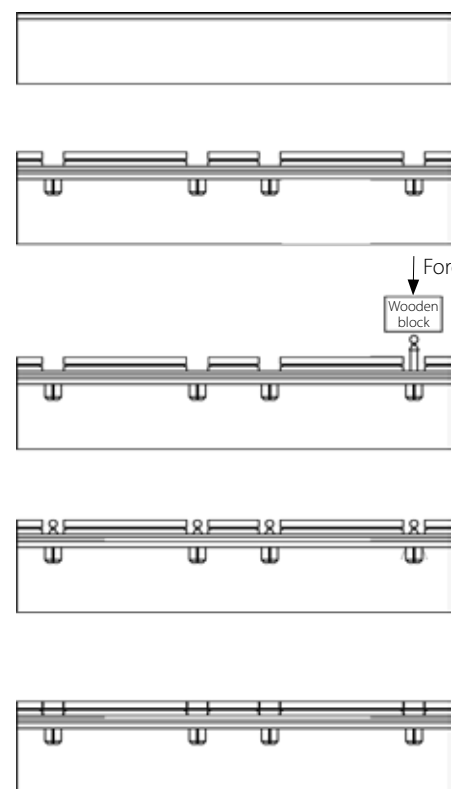

- 1 PS rail
- 2 Place the upgrade strip in position.
- 3 - Place the pin in position
- use a wooden block and sledge hammer to install the pin.
- 4 Repeat the previous step.
- 5 Rotate the pins to correct position.

Trellex LS – installation

Installation of PE/PU sideliner

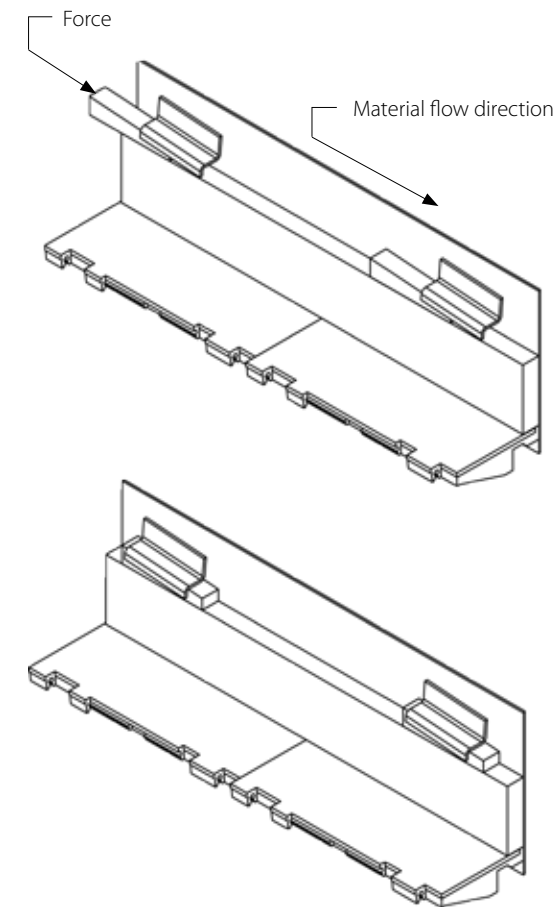
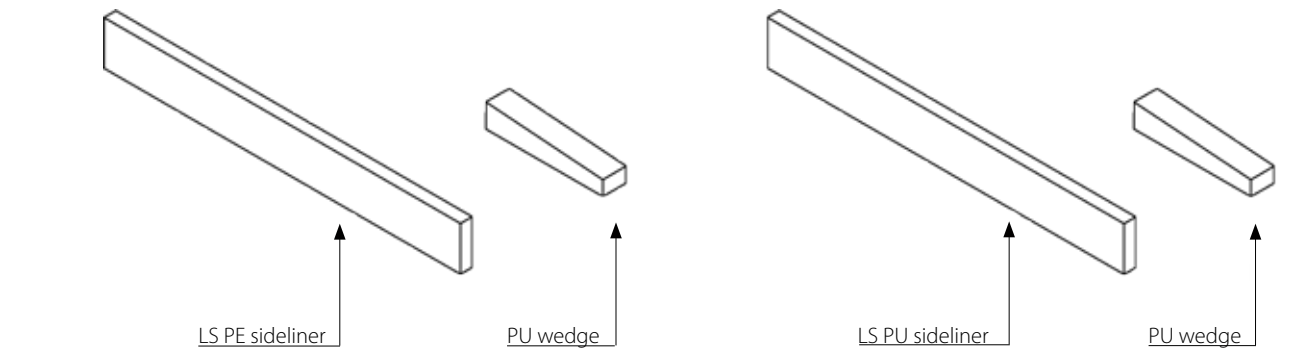

- 1 Place the wedge in position with the pointed nose in the material flow direction.
- 2 Apply force to install the wedge.

Trellex LS – installation

Installation of sideliner with groove

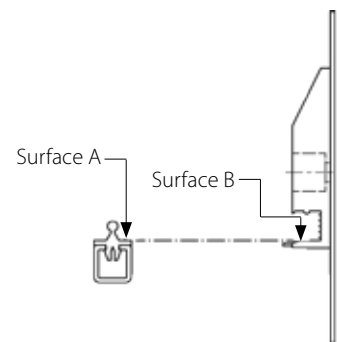
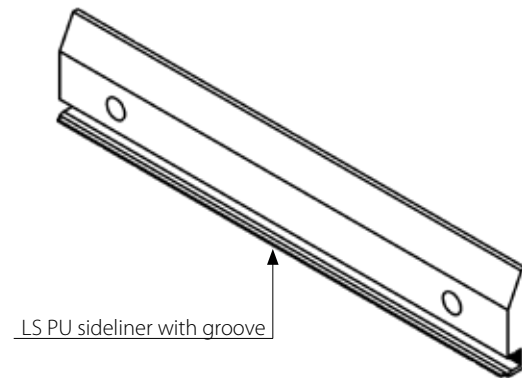

- 1 Locate the correct position for the sideliner, surface A should be in level with surface B.

Create necessary holes in the screen box and fasten the sideliner.

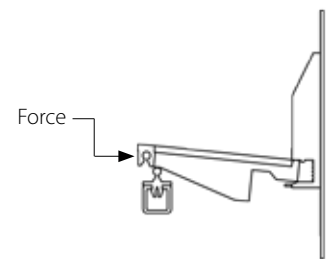

- 2 Apply force on the module to install it in the gap of the sideliner.

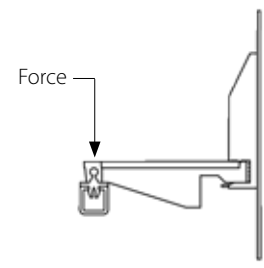

- 3 Apply force to install the module on the upgrade strip.

Trellex LS – installation

Installation of rails

SR rails for modular screen frames

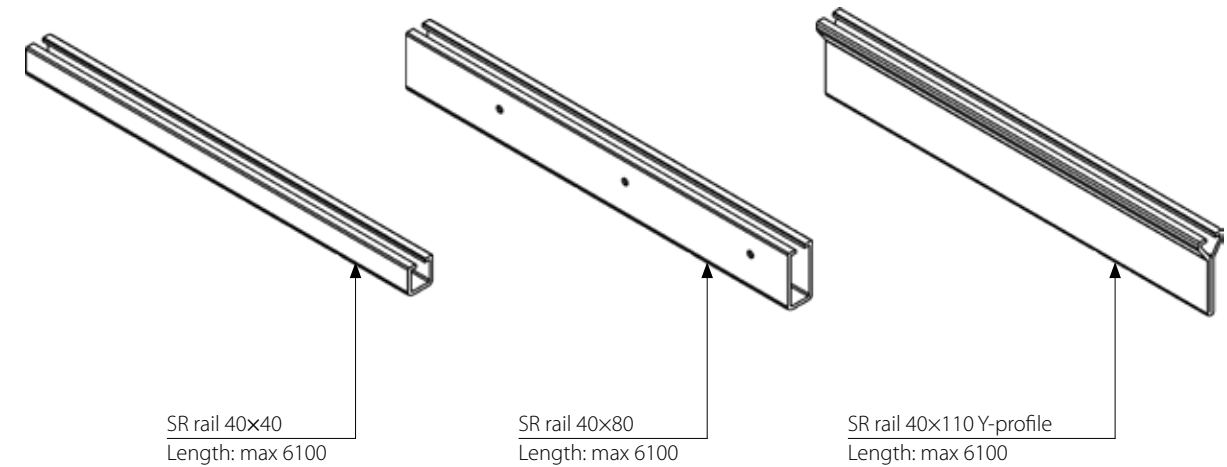

End stop guideline for SR rail

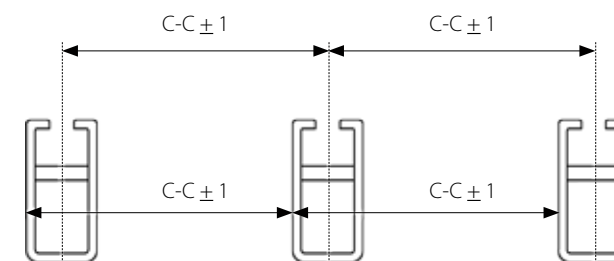
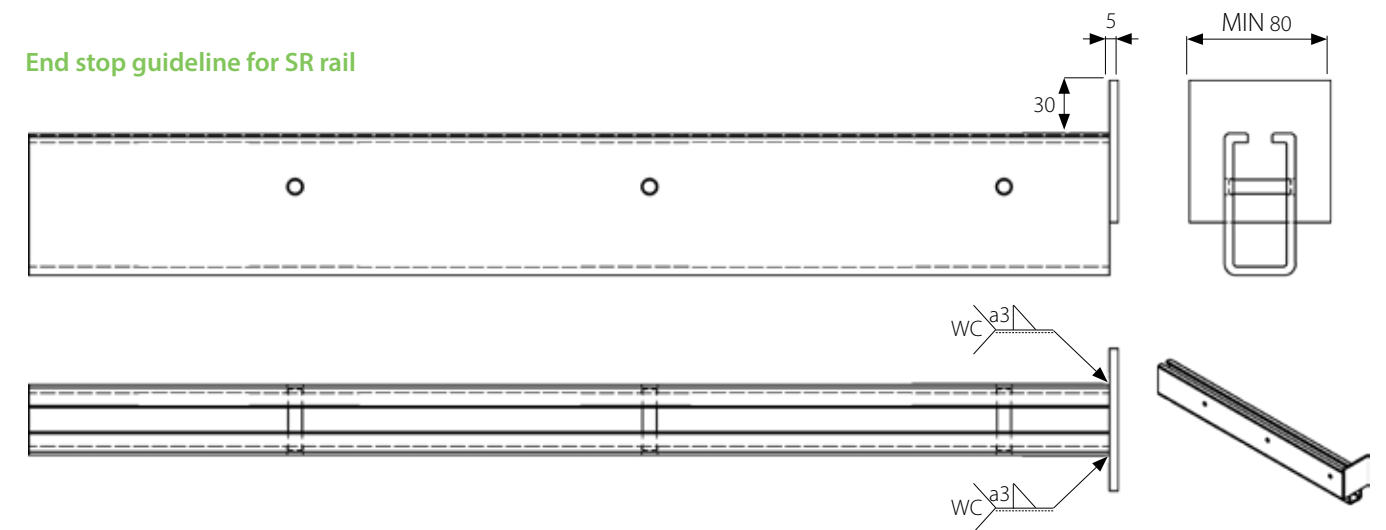

C-C distance for SR rail is normally 300 mm

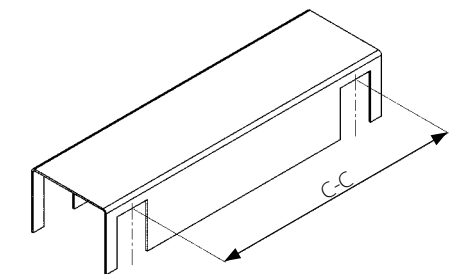

LS SR template C-C 300 Part No. ZX11162294
LS SR template C-C 305 Part No. ZX11352998

Trellex LS – installation

Trellex LS Wire Insert for SR rails wedge down side lining

Calculation of wire cloth width - (side)

- M** Distance between screen wall and center of SR rail
- N** Width of wire cloth (side)
 $N=(M - 30)$

Calculation of wire cloth width - (center)

- P** C-C distance between SR rail
- Q** Width of wire cloth (center)
 $Q=(P - 30)$

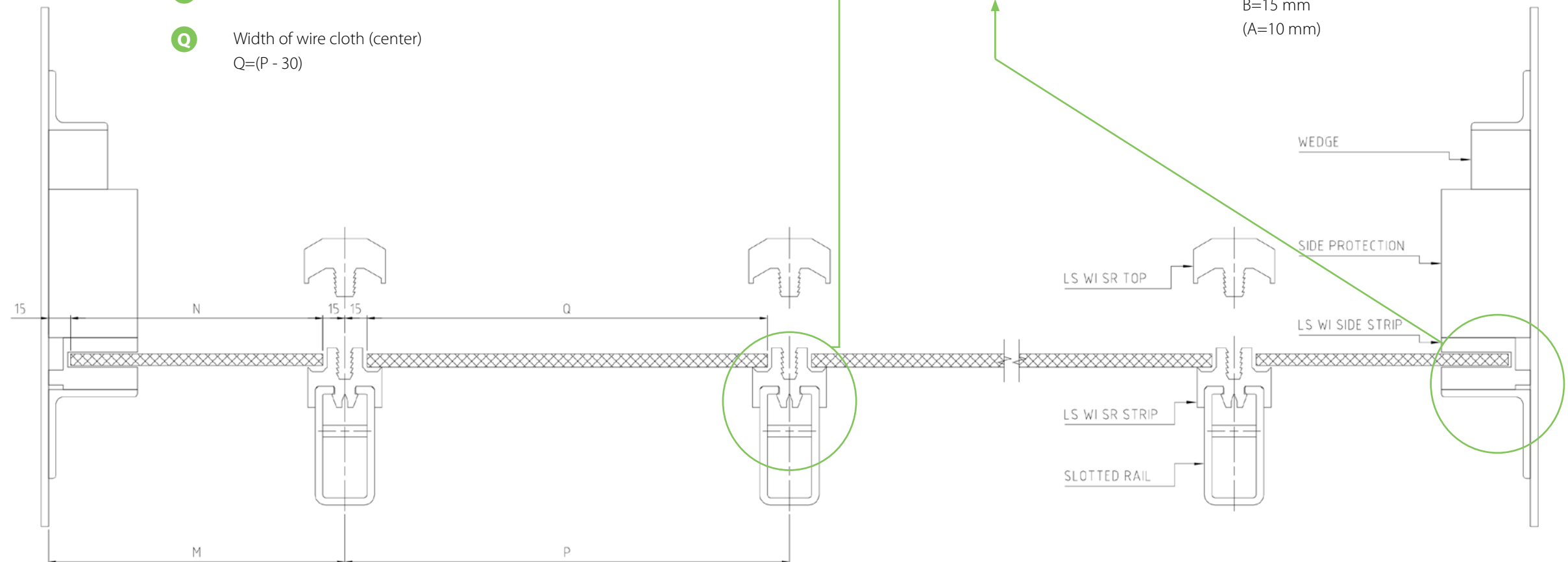

Selection of LS WI SR Strip

LS WI SR STRIP B15 for
 - wire cloth thread diameter ≤ 6 mm
 - screen cloth thickness max 12 mm

LS WI SR STRIP B10 for
 - wire cloth thread diameter > 6 mm
 - screen cloth thickness > 12 mm

Selection of LS WI Side Strip

For LS WI SR STRIP B15
 B=5, 10 or 15 mm
 (A=15 mm)

For LS WI SR STRIP B10
 B=15 mm
 (A=10 mm)

Trellex LS – installation

Trellex LS Wire Insert for PS rails wedge down side lining (bolt down strips)

Calculation of wire cloth width - (side)

- M** Distance between screen wall and center of PS rail
- N** Width of wire cloth (side)
 $N=(M + 2)$

Calculation of wire cloth width - (center)

- P** C-C distance between PS rail
- Q** Width of wire cloth (center)
 $Q=(P - 30)$

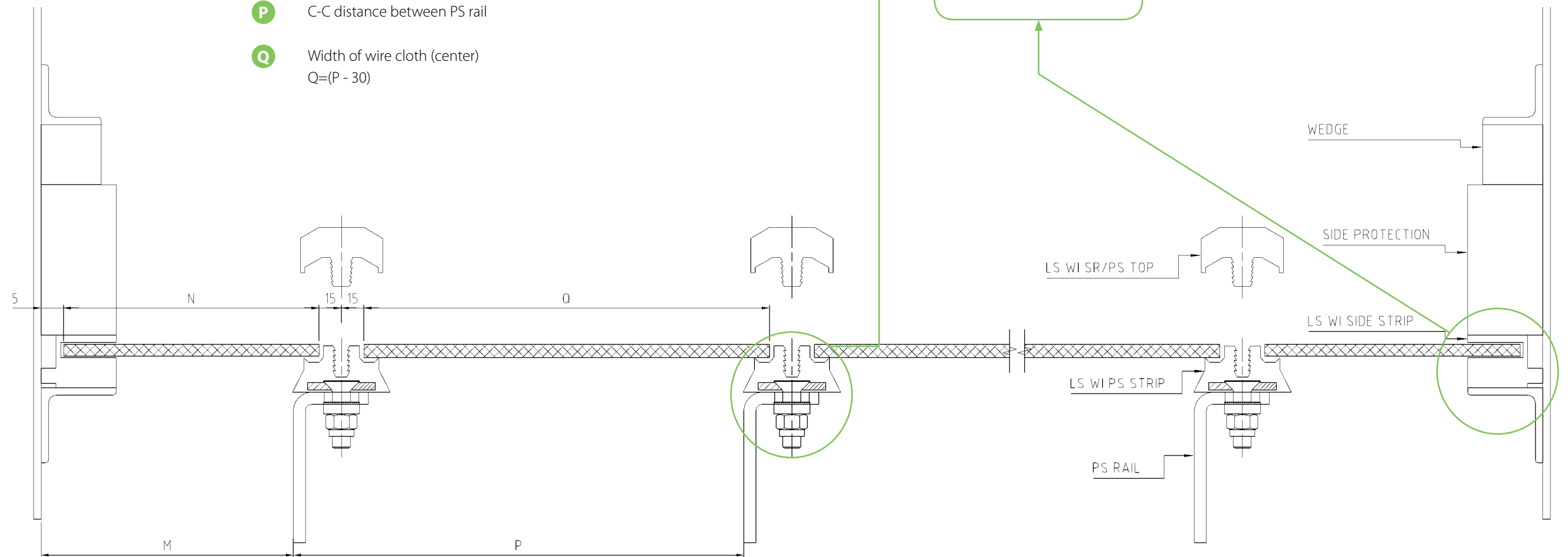

Selection of LS WI PS Strip

- LS WI PS STRIP 20
 - wire cloth thread diameter ≤ 6 mm
 - screen cloth thickness max 12 mm

Selection of LS WI SIDE Strip

- For LS WI PS STRIP B20
 - B = 5 or 10 mm
 - (A = 20 mm)

Trellex LS – installation

Trellex LS Wire Insert for PS rails wedge down side lining (sleeve expansion strips)

Calculation of wire cloth width - (side)

- M** Distance between screen wall and center of PS rail
- N** Width of wire cloth (side)
 $N=(M + 2)$

Calculation of wire cloth width - (center)

- P** C-C distance between PS rail

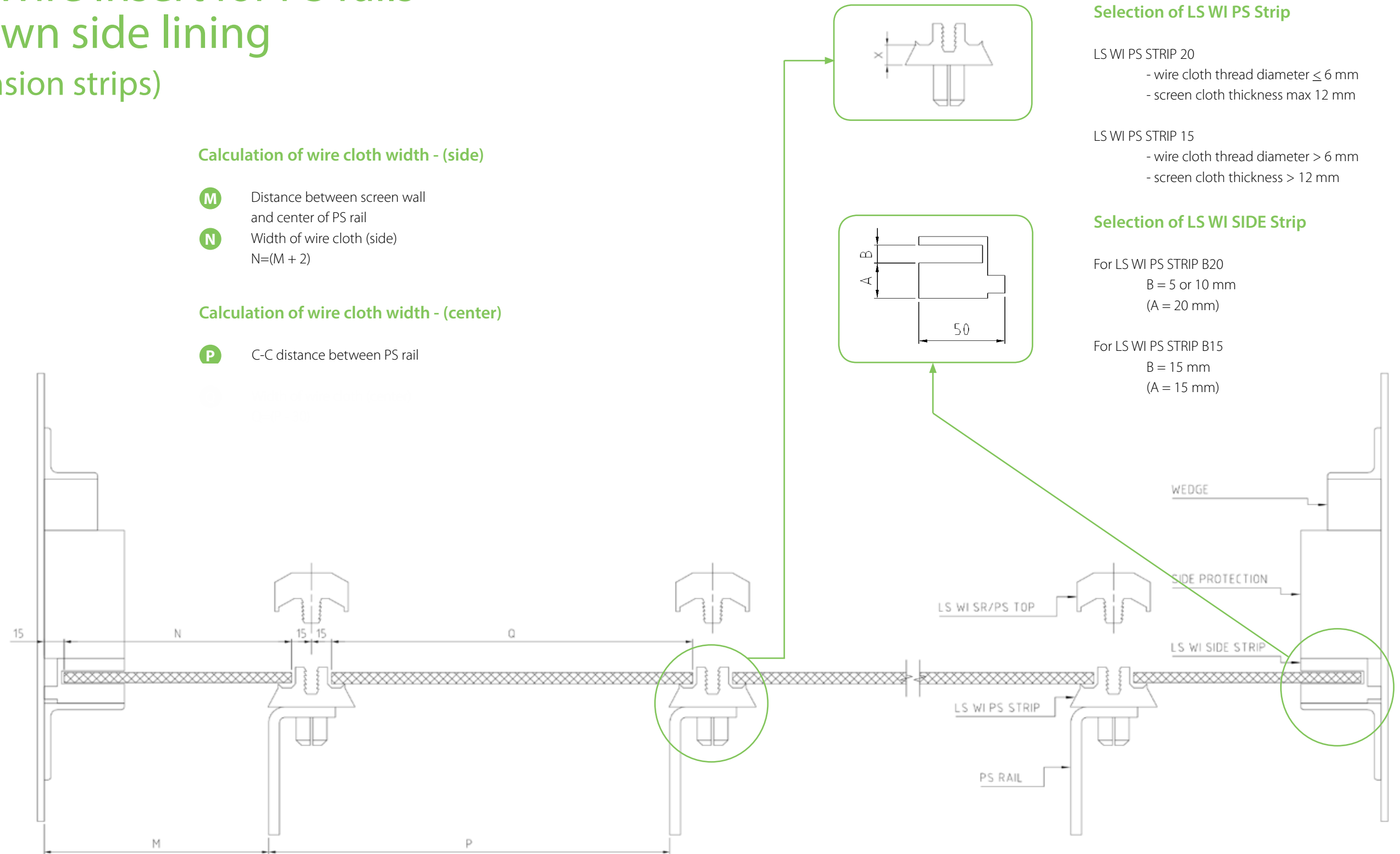

Selection of LS WI PS Strip

- LS WI PS STRIP 20
 - wire cloth thread diameter ≤ 6 mm
 - screen cloth thickness max 12 mm
- LS WI PS STRIP 15
 - wire cloth thread diameter > 6 mm
 - screen cloth thickness > 12 mm

Selection of LS WI SIDE Strip

- For LS WI PS STRIP B20
 - B = 5 or 10 mm
 - (A = 20 mm)
- For LS WI PS STRIP B15
 - B = 15 mm
 - (A = 15 mm)

Trellex LS – installation

Trellex LS Wire Insert for SR rails grooved side lining

Calculation of wire cloth width - (side)

- M** Distance between screen wall and center of SR rail
- N** Width of wire cloth (side)
 $N=(M - 33)$

Calculation of wire cloth width - (center)

- P** C-C distance between SR rail
- Q** Width of wire cloth (center)
 $Q=(P - 30)$

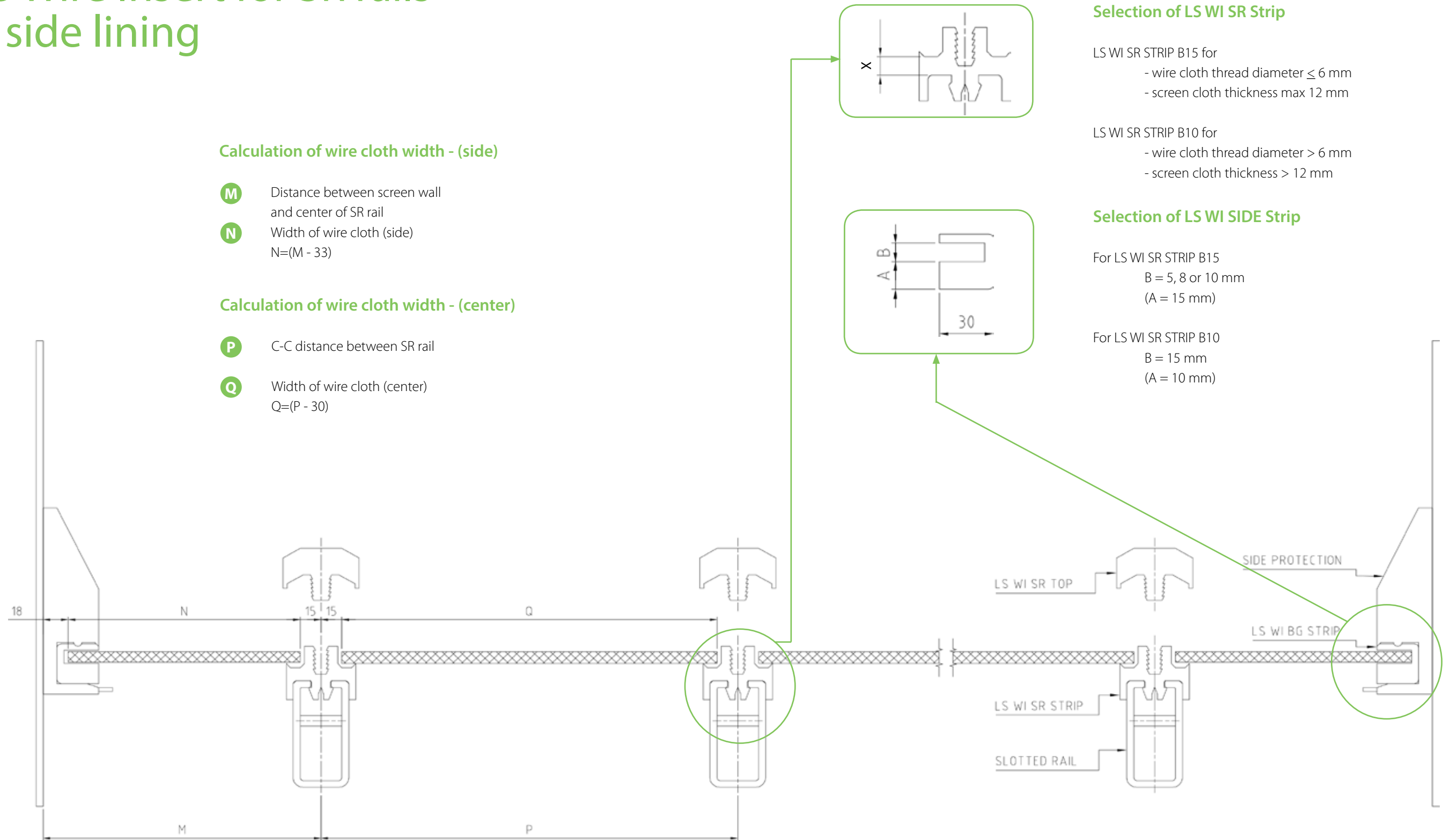

Selection of LS WI SR Strip

LS WI SR STRIP B15 for
 - wire cloth thread diameter ≤ 6 mm
 - screen cloth thickness max 12 mm

LS WI SR STRIP B10 for
 - wire cloth thread diameter > 6 mm
 - screen cloth thickness > 12 mm

Selection of LS WI SIDE Strip

For LS WI SR STRIP B15
 B = 5, 8 or 10 mm
 (A = 15 mm)

For LS WI SR STRIP B10
 B = 15 mm
 (A = 10 mm)



Trellex LS – installation

Trellex 300LS media templates for Metso TS-Screens

Metso TS screens have become immensely popular the last couple of years. The machines have banana curved decks where each deck consists of three slopes. Screening media templates have been prepared for each screen to assist in the selection, of compatible 300LS equipment.

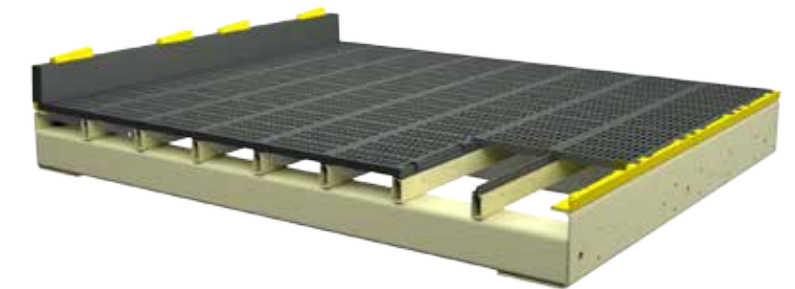

Each template can be found in Aton and is supplied with two documents. The first document is a part list with compatible products and quantities, required per screen deck. The second document is an illustrative drawing showing one section of a TS-screen, how a standard deck configuration is assembled.

TS2.X	Top Deck	Middle Deck	Bottom Deck
300LS RU BH30	MM0366957	MM0366957	MM0366957
300LS RU BH40	MM0366958	MM0366958	MM0366958
300LS RU BH60	MM0366959	NA	NA
300LS PU BH30	MM0369969	MM0369969	MM0369969

TS3.X	Top Deck	Middle Deck	Bottom Deck
300LS RU BH30	MM0366384	MM0366384	MM0366384
300LS RU BH40	MM0366385	MM0366385	MM0366385
300LS RU BH60	MM0366386	NA	NA
300LS PU BH30	MM0369970	MM0369970	MM0369970

TS4.X	Top Deck	Middle Deck	Bottom Deck
300LS RU BH30	MM0363825	MM0363825	MM0363825
300LS RU BH40	MM0363827	MM0363827	MM0363827
300LS RU BH60	MM0363828	NA	NA
300LS PU BH30	MM0363829	MM0363829	MM0363829

TS5.X	Top Deck	Middle Deck	Bottom Deck
300LS RU BH30	MM0361478	MM0361478	MM0361478
300LS RU BH40	MM0361549	MM0361549	MM0361549
300LS RU BH60	MM0361550	NA	NA
300LS PU BH30	MM0361592	MM0361592	MM0361592

TS6.X	Top Deck	Middle Deck	Bottom Deck
300LS RU BH30	MM0362413	MM0362413	MM0362413
300LS RU BH40	MM0362414	MM0362414	MM0362414
300LS RU BH60	MM0362415	NA	NA
300LS PU BH30	MM0362416	MM0362416	MM0362416

Trellex LS – installation

Trellex 305LS media templates for Metso CVB/ES screens

Configuration sheet ES 20X Trellex 305LS

Standard Deck Details	ES 20X TOP DECK					ES 20X BOTTOM DECK				
	PU		RU			PU		RU		
	BH30	BH40	BH30	BH40	BH60	BH30	BH40	BH30	BH40	BH60
Modules										
305LS PU BH30	48					48				
305LS PU BH40		48					48			
305LS RU BH30			48					48		
305LS RU BH40				48					48	
305LS RU BH60					48					48
Ledge angle profiles										
MM0375447					16					16
MM0375446		16		16			16		16	
MM0375431	16		16			16		16		
Side liners, rubbers and wedges										
MM0396818						8	8	8	8	8
MM0396817	8	8	8	8	8					
6670688	16	16	16	16	16	16	16	16	16	16
Upgrade strips										
6680378.10	4	4	4	4	4	4	4	4	4	4

Configuration sheet ES 30X Trellex 305LS

Standard Deck Details	ES 30X TOP DECK					ES 30X BOTTOM DECK				
	PU		RU			PU		RU		
	BH30	BH40	BH30	BH40	BH60	BH30	BH40	BH30	BH40	BH60
Modules										
305LS PU BH30	60					60				
305LS PU BH40		60					60			
305LS RU BH30			60					60		
305LS RU BH40				60					60	
305LS RU BH60					60					60
Ledge angle profiles										
MM0375447					20					20
MM0375446		20		20			20		20	
MM0375431	20		20			20		20		
Side liners, rubbers and wedges										
MM0396818						10	10	10	10	10
MM0396817	10	10	10	10	10					
6670688	20	20	20	20	20	20	20	20	20	20
Upgrade strips										
6680378.10	5	5	5	5	5	5	5	5	5	5

Trellex LS – installation

Configuration sheet ES 40X Trellex 305LS

Standard Deck Details	ES 40X TOP DECK					ES 40X BOTTOM DECK				
	PU		RU			PU		RU		
	BH30	BH40	BH30	BH40	BH60	BH30	BH40	BH30	BH40	BH60
Modules										
305LS PU BH30	80					80				
305LS PU BH40		80					80			
305LS RU BH30			80					80		
305LS RU BH40				80					80	
305LS RU BH60					80					80
Ledge angle profiles										
MM0375447					20					20
MM0375446		20		20			20		20	
MM0375431	20		20			20		20		
Side liners, rubbers and wedges										
MM0396818						10	10	10	10	10
MM0396817	10	10	10	10	10					
6670688	20	20	20	20	20	20	20	20	20	20
Upgrade strips										
6680378.10	7	7	7	7	7	7	7	7	7	7

Configuration sheet ES 50X Trellex 305LS

Standard Deck Details	ES 50X TOP DECK					ES 50X BOTTOM DECK				
	PU		RU			PU		RU		
	BH30	BH40	BH30	BH40	BH60	BH30	BH40	BH30	BH40	BH60
Modules										
305LS PU BH30	96					96				
305LS PU BH40		96					96			
305LS RU BH30			96					96		
305LS RU BH40				96					96	
305LS RU BH60					96					96
Ledge angle profiles										
MM0375447					24					24
MM0375446		24		24			24		24	
MM0375431	24		24			24		24		
Side liners, rubbers and wedges										
MM0396818						12	12	12	12	12
MM0396817	12	12	12	12	12					
6670688	24	24	24	24	24	24	24	24	24	24
Upgrade strips										
6680378.10	9	9	9	9	9	9	9	9	9	9

Trellex LS – installation

Continued from previous page

Configuration sheet ES 60X Trellex 305LS

Standard Deck Details	ES 60X TOP DECK					ES 60X BOTTOM DECK				
	PU		RU			PU		RU		
	BH30	BH40	BH30	BH40	BH60	BH30	BH40	BH30	BH40	BH60
Modules										
305LS PU BH30	120					120				
305LS PU BH40		120					120			
305LS RU BH30			120					120		
305LS RU BH40				120					120	
305LS RU BH60					120					120
Ledge angle profiles										
MM0375447					24					24
MM0375446		24		24			24		24	
MM0375431	24		24			24		24		
Side liners, rubbers and wedges										
MM0396818						12	12	12	12	12
MM0396817	12	12	12	12	12					
6670688	24	24	24	24	24	24	24	24	24	24
Upgrade strips										
6680378.10	11	11	11	11	11	11	11	11	11	11

Trellex LS – installation

Trellex LS media templates for Metso CIS - common screens

Standard deck details - LS Conversion

Standard Deck Details	GIS42		GIL51, 52, 53		GIT52, 53		SMD121		GIS62		GIST72	
	1500x4000		1750x4000		1750x4500		1750x5000		2000x6000		2500x6435	
	(pcs)		(pcs)		(pcs)		(pcs)		(pcs)		(pcs)	
Standard Modules												
300LS 500	LS Module 300x500 mm	24	40	45	50	60	91					
Side Modules												
LS-S 190-500	LS Side Module 190x500 mm					12	26					
LS-S 225-500	LS Side Module 225x500 mm		8	9	10							
LS-S 290-500	LS Side Module 290x500 mm	16				12						
Ledge angle profiles												
MM0350135	Fill out profiles to side wall	8	4	5	5	12	13					
MM0352715	Fill out profiles to side wall		8	9	10							
Side Liners, Rubber & wedges												
670088	Side liner Polyethylene 40x150x1000 mm	8	8	6	10	12	10					
6680783	Side liner Polyethylene 40x150x1525 mm			2			2					
6670688	PU Retaining wedge	16	16	16	20	24	24					
2971411	PU Retaining bracket	16	16	16	20	24	24					
358127	BOLT, M16X50-8.8-A3F	32	32	32	40	48	48					
212803	WASHER BRB 3x17/30	32	32	32	40	48	48					
315150	NUT M16 NYLOC	32	32	32	40	48	48					
Upgrade strips												
6680377.10	Standard SR upgrade strip box (10 pcs)	4	4	5	5	8	11					
Rails												
2020103	Slotted rail including stop plate	4	5									
6681478	Slotted rail including stop plate			5								
TBA	Slotted rail including stop plate				5							
MM0364101	Slotted rail including stop plate					6						
TBA	Slotted rail including stop plate						8					
Options												
6620642	Side liner PU 40x150x1000 mm	8	8	6	10	12	10					
6681430	Side liner PU 40x150x1525 mm			2			2					
MM0345414-10	Heavy Duty SR upgrade strip box (10 pcs)	4	4	5	5	8	11					
MM0358857	Protection plug for rail - no fines	4	5	5	5	6	8					

Adapted for circular beams not included.

Trellex LS modular system

Trellex 305PS

Trellex 305PS conforms with the most widespread modular standard in the world. This module size is used throughout the world and well known with OEM's making screens for the mining industry.



Our range of 305PS consists of the following main components:

- Injection molded polyurethane modules made from a variety of wear resistant materials. We offer high open area modules as well as heavy duty designs to meet all sorts of demands. Typical applications are **wet screening** and also dry screening with light duty loading.
- Open cast polyurethane modules for applications demanding **higher degree of abrasion** resistance. This type is also suitable when lump size and separations increase.
- Injection molded rubber modules with **anti-blinding characteristics**. Our long experience in the field of solving blinding screens has now been transferred into this product.
- Injection molded rubber modules to **extend wear life in demanding applications** with higher capacity and material beds. We offer a variety of designs and thicknesses to accommodate the most demanding applications you may find.



Modular system

Trellex 305PS-305

Trellex T40 Rubber - Injection moulded apertures

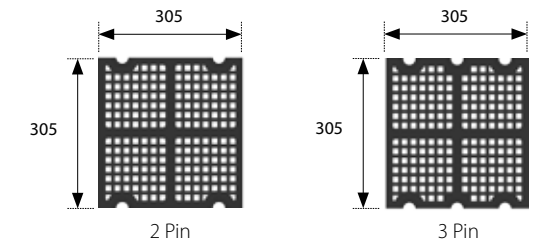

Hole type	Module weight (kg)	Thickness screen area (mm)	Quantity apertures per panel (mm)	Relative open area (%)	Effective open area (%)	Min web thickness with flow *	Min web thickness cross flow	Build height (mm)	Pin quantity	Extended EOA	Part No.
FR8	2.5	10	452	44.4%	31.1%	4	4	40	2	Y	MM0417079
FR11	2.6	14	240	44.4%	31.2%	5.5	5.5	40	2	Y	MM0418199
FR12	2.6	14	184	39.9%	28.5%	7	7	40	2	Y	MM0418202
FR21	2.9	25	64+16	46.7%	34.7%	11	8.5	40	2	N	
SLS8x29	3.2	25	119	41.3%	29.7%	6.4	10	40	2	N	ZX11369350
SLS10x30	3.5	25	91	40.7%	29.3%	8.9	9	40	2	N	
SLS12.5x50	4.2	25	40	34.9%	26.9%	12	23	40	2	N	ZX11396735
SLS12.5x50	4.2	25	40	34.9%	26.9%	12	23	40	3	N	
SLS19x50	3.4	25	32	41.2%	32.7%	13	22	40	2	N	



Modular system

Trellex 305PS-305

Trellex 305PS Attachment - Pins & Sleeves

Standard Duty Pin & Sleeve - Ø 32mm

Part No.	Description	Weight (kg)	Material	Module Build Height (mm)
PO/PIN/31	SM-ACC PIN Ø32 BH31	0.024	TPU/Ester/65Sh-D	31
PO/PIN/40	SM-ACC PIN Ø32 BH40	0.032	TPU/Ester/65Sh-D	40
PO/SLEEVE/SHORT	SM-ACC SLEEVE Ø32	0.022	TPU/Ester/95Sh-A	31-40

Standard Duty Pin & Sleeve - Ø 40mm

Part No.	Description	Weight (kg)	Material	Module Build Height (mm)
MM0426189	305PS PIN Ø40 BH40 ES	0.033	TPU/Ester/65Sh-D	40
MM0433217	305PS PIN Ø40 BH60 ES	0.053	TPU/Ester/65Sh-D	60
MM0426190	305PS SLEEVE Ø40x42 ES	0.022	TPU/Ester/95Sh-A	40-60

Standard Duty Pin & Sleeve - Ø 40mm (Kit in boxes)

Part No.	Description	Weight (kg)	Fixing Pin Included	Insert Included
MM0426224	305PS PIN Ø40 BH40 + SLEEVE (100 PCS)	5.5	MM0426189	MM0426190
MM0433229	305PS PIN Ø40 BH60 + SLEEVE (100 PCS)	7.5	MM0433217	MM0426190

Heavy Duty Knock-through Pin & Sleeve - Ø 40mm

Part No.	Description	Weight (kg)	Material	Module Build Height (mm)
T24002030	305PS FIXING PIN Ø40 BH60 HD ES	0.066	TPU/Ester/95Sh-A	60
ZX11336023	305PS FIXING PIN Ø40 BH40 HD ES	0.049	TPU/Ester/95Sh-A	40
T24002029	305PS INSERT Ø13X105 ES	0.016	TPU/Ester/64Sh-D	40-60

Heavy Duty Knock-through Pin & Sleeve - Ø 40mm (Kit in Boxes)

Part No.	Description	Weight (kg)	Fixing Pin Included	Insert Included
MM0424599	305PS FIXING PIN BH40+INSERT (100 PCS)	6.5	100 pcs ZX11336023	100 pcs T24002029
MM0424602	305PS FIXING PIN BH60+INSERT (100 PCS)	8.2	100 pcs T24002030	100 pcs T24002029



Modular system

Trellex 305PS-305

Trellex T60 Rubber - Injection moulded apertures

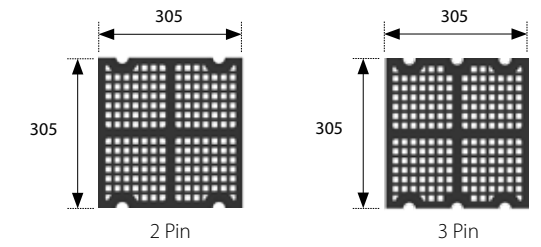

Hole type	Module weight (kg)	Thickness screen area (mm)	Quantity apertures per panel (mm)	Relative open area (%)	Effective open area (%)	Min web thickness with flow *	Min web thickness cross flow	Build height (mm)	Pin quantity	Extended EOA	Part No.
FR8	2.5	10	452	44.4%	31.1%	4	4	40	2	Y	MM0420152
FR11	2.6	14	240	44.4%	31.2%	5.5	5.5	40	2	Y	MM0420151
FR12	2.6	14	184	39.9%	28.5%	7	7	40	2	Y	MM0420150
SLS8x29	3.2	25	119	41.3%	29.7%	6.4	10	40	2	N	ZX11343511
SLS10x30	3.5	25	91	40.7%	29.3%	8.9	9	40	2	N	ZX11366404
SLS10x32	5	35	78	37.2%	26.8%	8.7	14	60	2	N	ZX11366402
SLS12.5x50	4.2	25	40	34.9%	26.9%	12	23	40	2	N	ZX11396736
SLS12.5x50	4.2	25	40	34.9%	26.9%	12	23	40	3	N	ZX11372183
SLS12.5x50	5.2	45	40	34.9%	26.9%	12	23	60	2	N	ZX11396679
SLS12.5x50	5.2	45	40	34.9%	26.9%	12	23	60	3	N	ZX11372110
SLS19x50	3.4	25	32	41.2%	32.7%	13	22	40	2	N	MM0432337
FR21	2.9	25	64+16	46.7%	34.7%	11	8.5	40	2	N	MM0432335
FR32	2.9	30	30	42.0%	33.0%	21	14	40	2	N	MM0418123
FR35	2.7	30	30	51.1%	39.5%	16	12	40	2	N	MM0424710
SLS36x65	4.5	45	12	34.6%	30.1%	30.1	37.3	60	2	N	ZX11343512
SLS36x65	4.5	45	12	34.6%	30.1%	30.1	37.3	60	3	N	
SLS40x70	5.2	45	12	43.8%	36.1%	24	30	60	2	N	ZX11392274
SLS40x70	5.2	45	12	43.8%	36.1%	24	30	60	3	N	ZX11396571

With skidbars

Hole type	Module weight (kg)	Thickness screen area (mm)	Quantity apertures per panel (mm)	Relative open area (%)	Effective open area (%)	Min web thickness with flow *	Min web thickness cross flow	Build height (mm)	Pin quantity	Skid bar height (mm)	Part No.
FR36	4.4	45	25	44.3%	34.8%	14	22.4	60	2	15	ZX11341972
SLS36x65	5	45	12	34.6%	30.1%	30.1	37.3	60	2	15	ZX11354283
SLS40x70	5.8	45	12	43.8%	36.1%	24	30	60	2	15	ZX11389591
SLS40x70	5.8	45	12	43.8%	36.1%	24	30	60	3	15	ZX11396573

Blank panels

Hole type	Module weight (kg)	Thickness screen area (mm)	Build height (mm)	Pin quantity	Skid bar height (mm)	Part No.
BLANK	5.2	25	40	3	0	ZX11372182
BLANK	7.4	45	60	2	0	ZX11396985
BLANK	6.6	45	60	2	15	ZX11351828

Modular system

Trellex 305PS-305

Trellex T60S Rubber - Injection moulded apertures

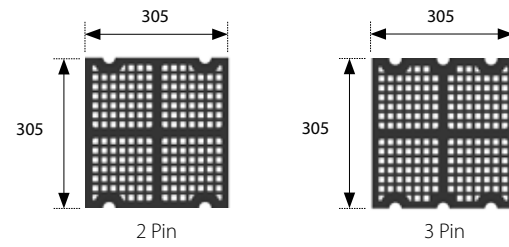

Hole type	Module weight (kg)	Thickness screen area (mm)	Quantity apertures per panel (mm)	Relative open area (%)	Effective open area (%)	Min web thickness with flow *	Min web thickness cross flow	Build height (mm)	Pin quantity	Extended EOA	Part No.
FR8	2.5	10	452	44.4%	31.1%	4	4	40	2	Y	
FR11	2.6	14	240	44.4%	31.2%	5.5	5.5	40	2	Y	
FR12	2.6	14	184	39.9%	28.5%	7	7	40	2	Y	
SLS8x29	3.2	25	119	41.3%	29.7%	6.4	10	40	2	N	
SLS10x30	3.5	25	91	40.7%	29.3%	8.9	9	40	2	N	
SLS10x32	5	35	78	37.2%	26.8%	8.7	14	60	2	N	ZX11386591
SLS12.5x50	4.2	25	40	34.9%	26.9%	12	23	40	2	N	ZX11396737
SLS12.5x50	4.2	25	40	34.9%	26.9%	12	23	40	3	N	ZX11389578
SLS12.5x50	5.2	45	40	34.9%	26.9%	12	23	60	2	N	ZX11396734
SLS12.5x50	5.2	45	40	34.9%	26.9%	12	23	60	3	N	ZX11389577
SLS19x50	3.4	25	32	41.2%	32.7%	13	22	40	2	N	
FR21	2.9	25	64+16	46.7%	34.7%	11	8.5	40	2	N	
FR32	2.9	30	30	42.0%	33.0%	21	14	40	2	N	
FR35	2.7	30	30	51.1%	39.5%	16	12	40	2	N	
SLS36x65	4.5	45	12	34.6%	30.1%	30.1	37.3	60	2	N	
SLS40x70	5.2	45	12	43.8%	36.1%	24	30	60	2	N	
SLS40x70	5.2	45	12	43.8%	36.1%	24	30	60	3	N	ZX11396572

Trellex 60S Rubber - Injection moulded apertures with skid bars

Hole type	Module weight (kg)	Thickness screen area (mm)	Quantity apertures per panel (mm)	Relative open area (%)	Effective open area (%)	Min web thickness with flow *	Min web thickness cross flow	Build height (mm)	Pin quantity	Extended EOA	Part No.
FR36	4.4	45	25	44.3%	34.8%	14	22.4	60	2	10	
SLS36x65	5	45	12	34.6%	30.1%	30.1	37.3	60	2	15	
SLS40x70	5.8	45	12	43.8%	36.1%	24	30	60	2	15	ZX11389592
SLS40x70	5.8	45	12	43.8%	36.1%	24	30	60	3	15	ZX11396574

Trellex 60S Rubber -Blank Panels

Hole type	Module weight (kg)	Thickness screen area (mm)	Build height (mm)	Pin Quantity	Skid bar height (mm)	Part No.
BLANK	5.2	25	40	3	0	ZX11389579
BLANK	7	45	60	2	0	ZX11397001
BLANK	6.8	45	60	2	15	ZX11389580
BLANK	7.5	45	60	2	15	

Modular system

Trellex 305PS-305

TPU (Thermoplastic PU) - Polyester

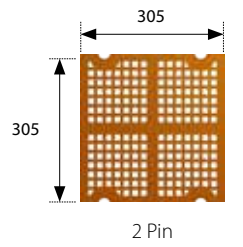

Standard modules 305x305x31 mm, Pin Diameter 32mm

Hole type	Module weight (kg)	Thickness screen area (mm)	Quantity apertures per panel (mm)	Relative open area (%)	Effective open area (%)	Min web thickness with flow *	Min web thickness cross flow	Build height (mm)	Pin quantity	Extended EOA	Part No.
SLS0.5x12M	2.5	8	1352	11.9%	8.7%	2.9	2.8	31	2	Y	MM0422308
SLS0.63x12M	2.4	8	1250	14.5%	10.0%	2.9	2.8	31	2	Y	MM0415694
SLS0.8x12M	2.4	8	1126	16.6%	12.0%	3.1	2.8	31	2	Y	MM0415693
SLS1x12M	2.4	8	1160	20.8%	15.0%	2.9	2.8	31	2	Y	MM0415432
SLS8x12M	2.4	14	236	33.7%	24.4%	7	7	31	2	Y	MM0421698
SLS15x50	3	25	44	49.4%	35.5%	8	16	31	2	Y	MM0427648
STS0.5x12M	2.5	8	1352	11.9%	8.7%	2.8	2.9	31	2	Y	MM0422310
STS0.63x12M	2.4	8	1232	14.5%	10.0%	2.8	2.9	31	2	Y	MM0415764
STS0.8x12M	2.4	8	1160	16.6%	12.0%	2.8	3.1	31	2	Y	MM0415692
STS1x12M	2.6	8	940	19.0%	12.1%	2.5	6	31	2	Y	MM0428789
FR3M	2.2	5	1916	30.9%	18.5%	2.4	2.4	31	2	Y	MM0424298
FR8M	2.5	10	452	44.4%	31.1%	4	4	31	2	Y	MM0428674
FR12M	2.4	14	184	39.9%	28.5%	7	7	31	2	Y	MM0421697
FR17M	2.6	25	136	54.6%	42.3%	6	6	31	2	Y	MM0427647
FR25M	2.6	20	60	55.7%	40.3%	8.5	8.5	31	2	Y	MM0420661
FR32M	2.9	25	30	44.9%	33.0%	21	11	31	2		MM0420662
FR40M	2.8	25	20+5	51.9%	40.8%	16	15	31	2		MM0421695

"L-shaped" standard modules 305x305x31 mm, Pin Diameter 32mm Dambar L=30, H=50 mm

Hole type	Module weight (kg)	Thickness screen area (mm)	Quantity apertures per panel (mm)	Relative open area (%)	Effective open area (%)	Min web thickness with flow *	Min web thickness cross flow	Build height (mm)	Pin quantity	Extended EOA	Part No.
SLS0.5x12M	2.8	8	1304	11.9%	8.4%	2.8	2.9	31	2	Y	MM0422309
SLS0.63x12M	2.8	8	1210	14.5%	9.8%	2.9	2.8	31	2	Y	MM0416754
SLS0.8x12M	2.9	8	1091	16.6%	11.3%	3.1	2.8	31	2	Y	MM0416752
SLS1x12M	2.8	8	1124	20.8%	14.5%	2.9	2.8	31	2	Y	MM0416750
SLS15x50	3	25	44	49.4%	35.5%	8	16	31	2	Y	MM0429408
STS0.5x12M	2.8	8	1304	11.9%	8.4%	2.8	2.9	31	2	Y	MM0422311
STS0.63x12M	2.8	8	1210	14.5%	9.8%	2.8	2.9	31	2	Y	MM0416758
STS0.8x12M	2.8	8	1091	16.6%	11.3%	2.8	3.1	31	2	Y	MM0416756

Standard modules 305x305x40 mm, Pin Diameter 32mm

Hole type	Module weight (kg)	Thickness screen area (mm)	Quantity apertures per panel (mm)	Relative open area (%)	Effective open area (%)	Min web thickness with flow *	Min web thickness cross flow	Build height (mm)	Pin quantity	Extended EOA	Part No.
SLS12.5x55M	3.3	30	44	44.8%	32.5%	8.5	18	40	2	Y	MM0421708

Blank modules 305x305 mm, Pin Diameter 32mm

Hole type	Module weight (kg)	Thickness screen area (mm)	Build height (mm)	Pin Quantity	Part No.
BLANK	3,7	16	31	2	MM0416846
BLANK	4,7	25	40	2	MM0416848

TENSION SYSTEM

Tension system – overview

Metso Tension systems include a variety of options from fine to coarse screening. With solutions including everything from rubber and polyurethane to classic wire, Metso Tension systems offer versatile screen media that provide performance and cost-effectiveness for a wide range of screen duties. All solutions are tailor-made to your application, and come complete with tension hooks to suit your screen.



TENSION SYSTEM

Trellex TFX

Anti-blinding screen surface for fine and sticky materials

Trellex TFX is a complete system purposely designed for fine screening of materials that tend to cause conventional classic wire to blind over.

The TFX secret lies in its thin, flexible soft rubber (T40) membrane type screen cloth, supported by reinforced rubber spacers, that provides extremely accurate separations. The highly flexible screening area counteracts blinding. As standard, all TFX cloths are manufactured with a Bucker bar over the support irons to avoid damage to the cloth.



Total concept

Trellex TFX is packaged as a complete system and includes:

- Screen cloth
- Tension hooks
- Center hold-downs (recommended for widths of 1300 mm or more)

Multi-purpose screen surface

Trellex TFX is well-suited for all types of materials, but is particularly effective on challenging materials that cause blinding:

- Limestone
- Granite
- Gravel
- Andalusite
- Copper
- Clay
- Platinum
- Iron ore
- Sand
- Diamonds
- Fertilizers
- Coal



TENSION SYSTEM

Trellex TFX

Trellex TFX – molded apertures

Part No.	Aperture size	Thickness (mm)	Weight* (kg/m ²)	Rubber quality	Remark
SMS-TX410-002	FR3.2 (2mm Separation)	3.5	5.00	Trellex 40	Bucker bar protection
SMS-TX410-002	FR5.4 (2mm Separation)	3.5	5.00	Trellex 40	Bucker bar protection

Membrane dimensions: 1000x3000 / 1220x3000 / 1520x3000

* Weight includes hooks
Standard = bucker bar protection

Trellex TFX – punched apertures

Part No.	Thickness (mm)	Weight* (kg/m ²)	Rubber quality	Remark
SMS-TX410-002	3.5	5,00	Trellex 40	Bucker bar protection
SMS-TX410-002	5.5	6,00	Trellex 40	Bucker bar protection
SMS-TX410-002	8	8,00	Trellex 40	Bucker bar protection

Membrane dimensions: 1000x3000 / 1220x3000 / 1520x3000

* Weight includes hooks
Standard = bucker bar protection

Hooks for Trellex TFX

Part No.	Description
2039040	AO / BO
2039045	AU / BU / AUD
2039042	C145 / C150 / C180

Sketches of hooks: see Trellex TCO
Standard = bucker bar protection

Bucker bar protection requires suitable rubber cappings on longitudinal supports.

See page 179 for Trellex U-capping range.





TENSION SYSTEM

Trellex TCO RU

For fine to coarse screening

Trellex TCO is an all-round cloth designed primarily for final products of 4 - 100 mm.

Trellex TCO is made of T60 wear-resistant rubber and features special heat-treated cord reinforcement that facilitates tensioning and also maintains the proper tension without the need for continual adjustment. The reinforcement also reduces the degree of tensioning, which contributes to longer service life. Trellex TCO screen cloths are fitted with tension hooks as standard. For screen widths exceeding of 1300 mm, center hold-downs should be used. Trellex TCO is normally used for thicknesses of 5-50 mm.

All Trellex TCO are custom-made to fit any screen cross tension or longitudinal tension.

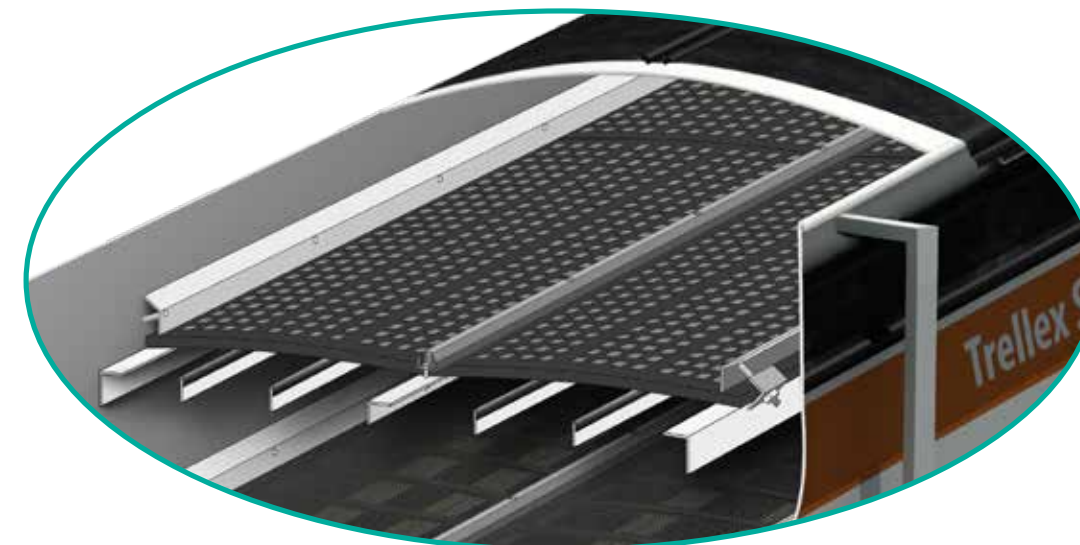

Trellex TCO – punched apertures

Part No.	Thickness (mm)	Roll widths (mm)	Weight* (kg/m ²)
SMS-TX402-001	5	1000 / 1270 / 1525	6
SMS-TX402-002	7	1000 / 1270 / 1525	8
SMS-TX402-003	10	1000 / 1270 / 1525	12
SMS-TX402-004	15	1000 / 1270 / 1525	17
SMS-TX402-005	20	1000 / 1270 / 1525	23
SMS-TX402-006	25	1000 / 1270 / 1525	29
SMS-TX402-007	35	1000 / 1270 / 1525	40
SMS-TX402-008	50	Max. 1500 x 3000	58

* Weight includes hooks.
Apertures normally from 4 to 100 mm FR, SLS, STS, C.

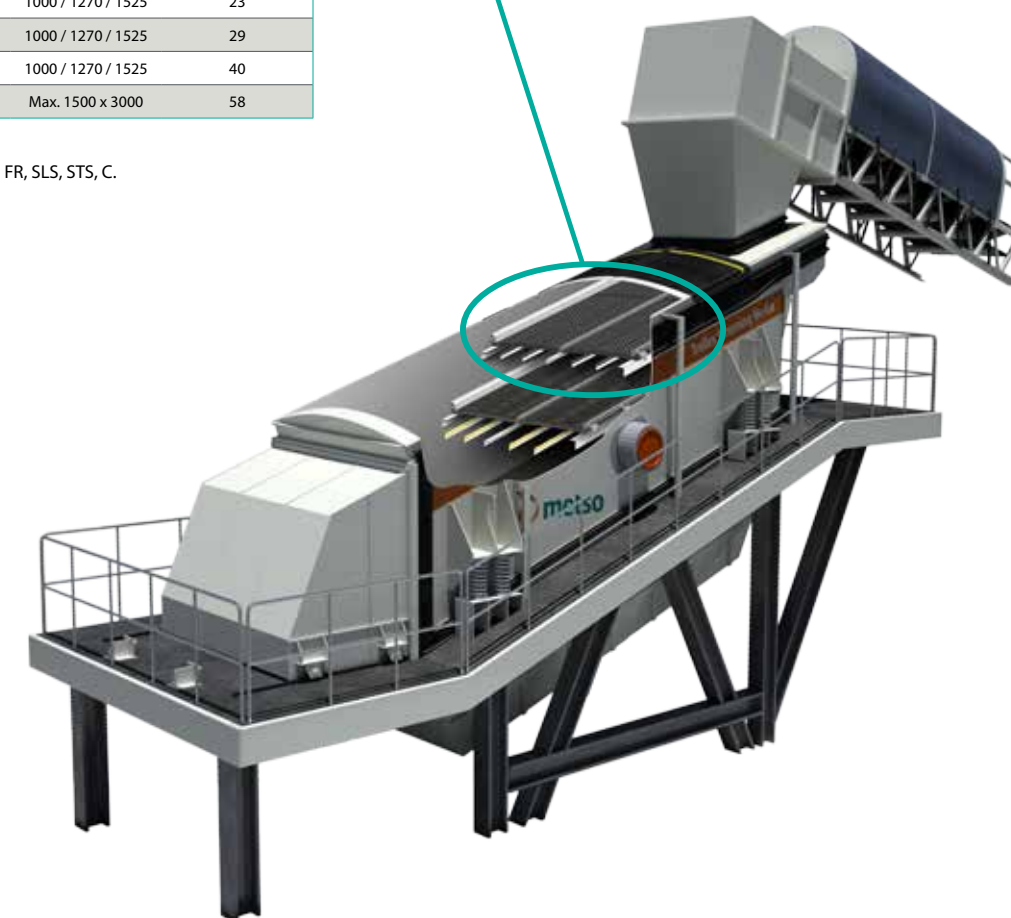

TENSION SYSTEM

Hooks for Trellex TCO and Trellex TFX

Hooks for side tensioned cloths

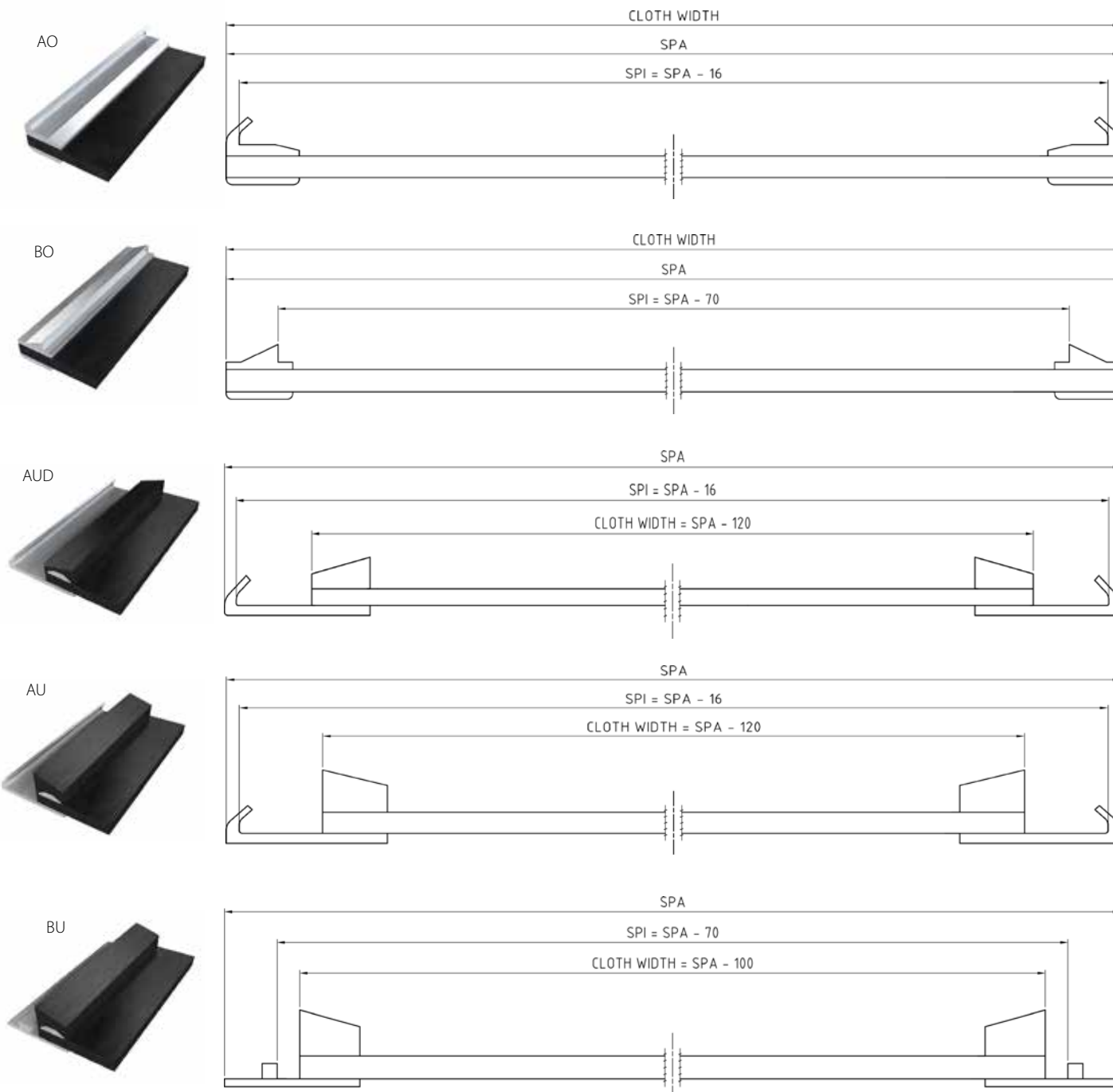

Hooks for longitudinal tensioned cloths

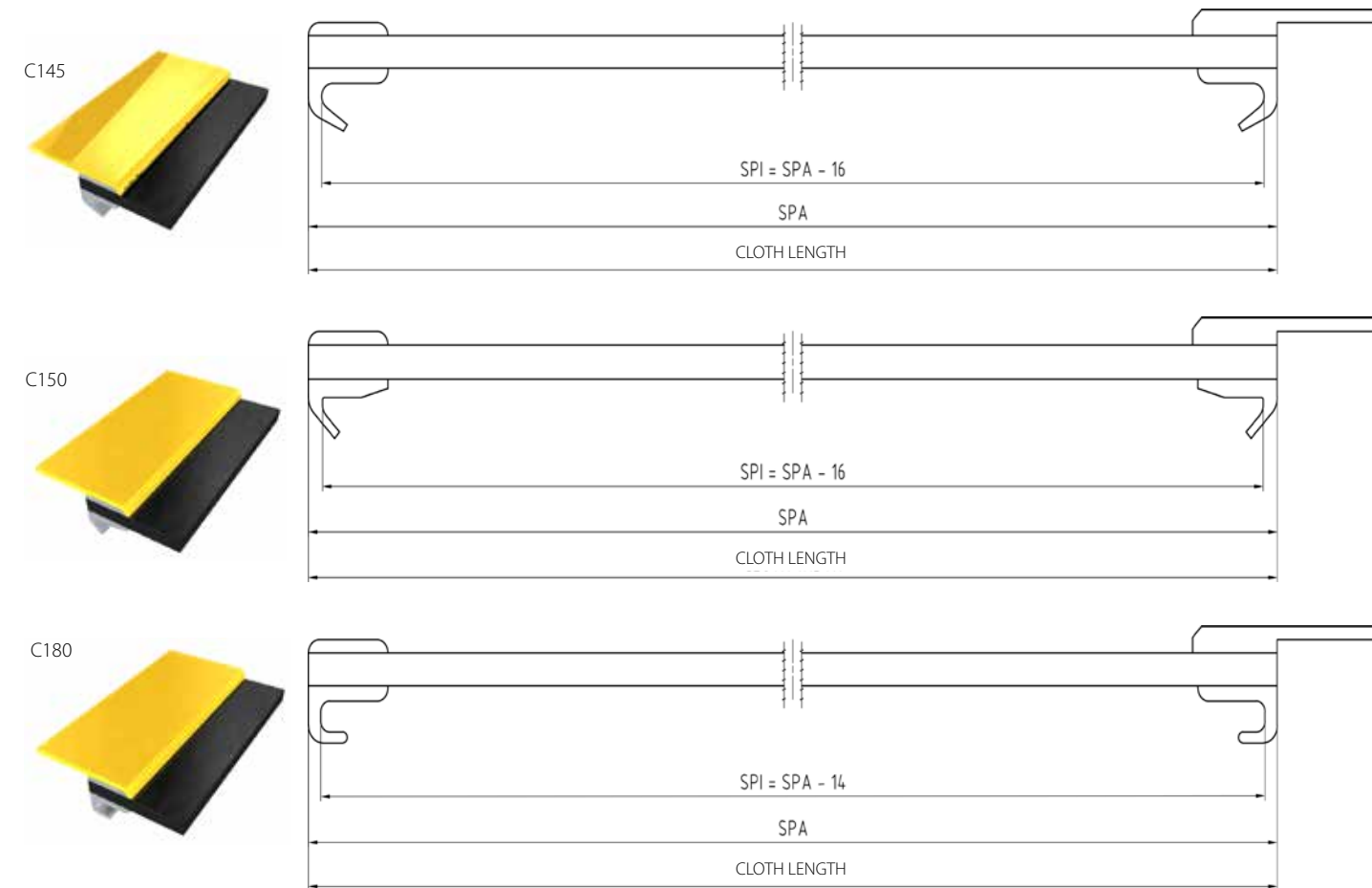

To avoid damages on Trellex TCO Cloth, U-cappings on longitudinal supports are required. See page 169 for Trellex U-capping range.

TENSION SYSTEM

Trellex TCO PU

For fine to coarse screening

Trellex TCO-PU is a screen cloth made of highly wear-resistant polyurethane. It is purposely designed for use on longitudinally and transversely tensioned screens for screening in the medium and fine ranges.

Trellex TCO-PU panels are especially suited to wet screening. They fit all vibrating screens in the same way as conventional rubber screen panels, so that no modification to the support frame is needed. The configuration of each panel can be manufactured to suit your needs.

Apertures are either slotted or square. Precision-molded apertures ensure consistently accurate sizing. Reinforced by steel cables, Trellex TCO-PU is tensioned exactly as a wire mesh panel - reducing the potential for elongation to zero. A wide range of standard side hooks is available to suit your requirements.

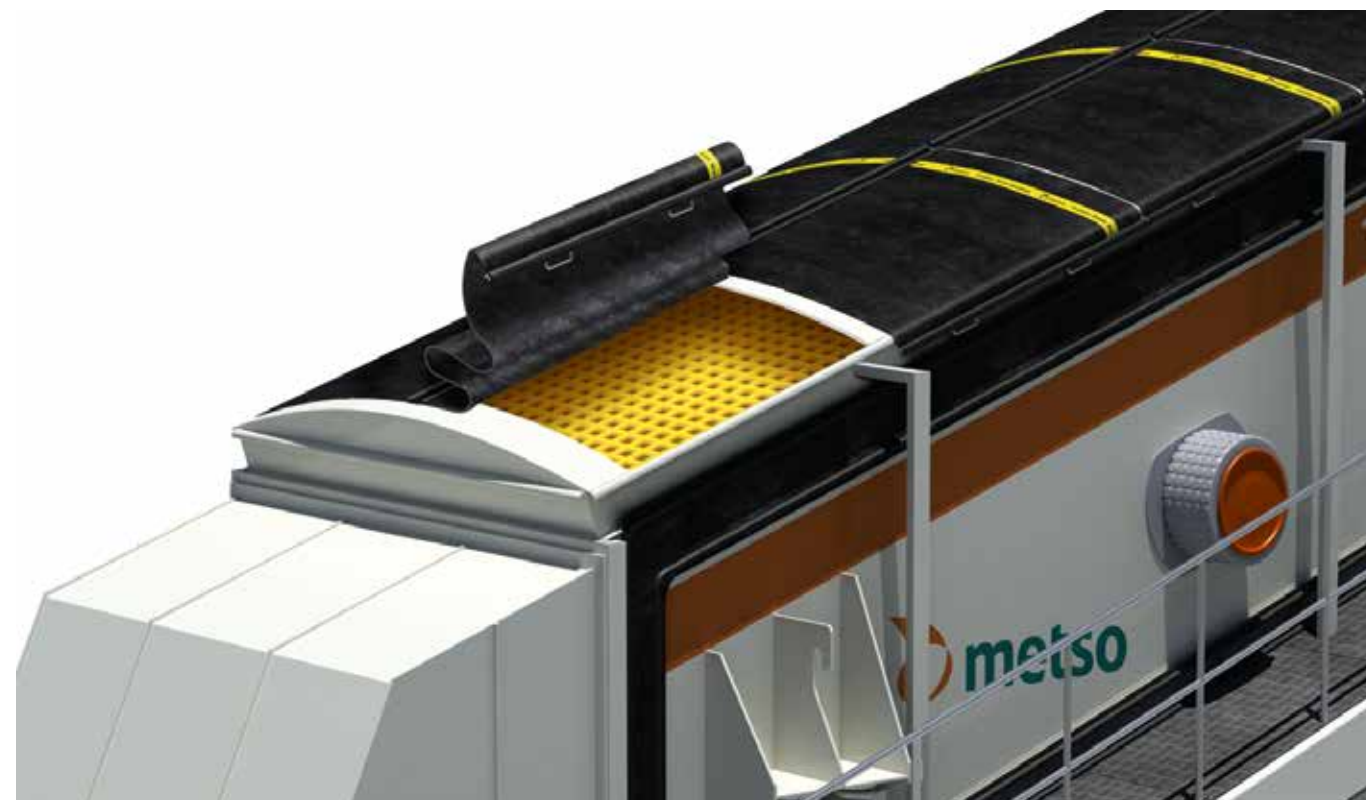

Hook types TCO-PU

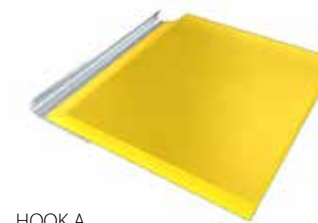

HOOK A

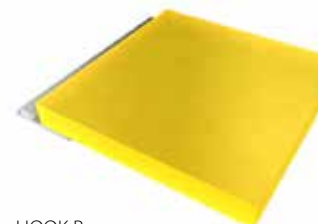

HOOK B

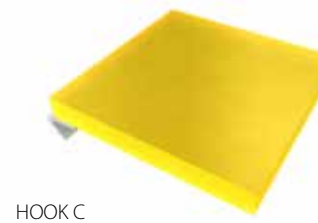

HOOK C

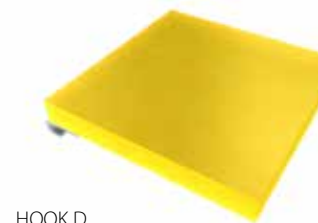

HOOK D

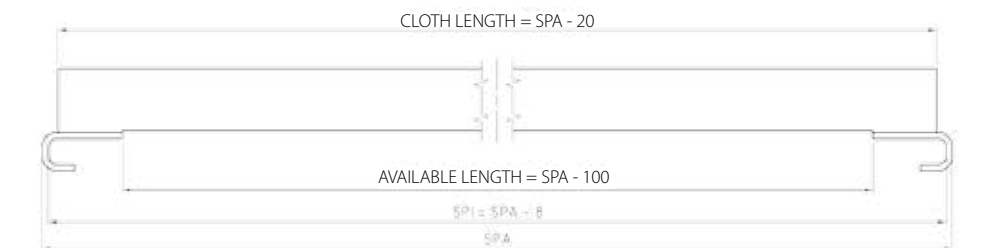

Max dimensions:
SPA=2800 mm
Cloth length/width:
L=1800 mm

Trellex TCO PU Standard

Trellex TCO PU

Square Apertures (FR)

Part No.	Aperture size	Total thickness/ Wear thickness (mm)	Relative open area (%)
SMS-TX401-001	FR 3.3	25/6	39
SMS-TX401-001	FR 4.5	25/8	41
SMS-TX401-001	FR 5.5	25/8	43
SMS-TX401-001	FR 6.5	25/8	47
SMS-TX401-001	FR 7.5	25/9	51
SMS-TX401-001	FR 8.5	25/10	55
SMS-TX401-001	FR 9.5	25/12	43
SMS-TX401-001	FR 9.5 LD	25/10	57
SMS-TX401-001	FR 10	25/12	44
SMS-TX401-001	FR 10.5 LD	25/11	56
SMS-TX401-001	FR 11	25/15	44
SMS-TX401-001	FR 11.5 LD	25/12	63
SMS-TX401-001	FR 12.5	25/13	39
SMS-TX401-001	FR 13.5	25/13	46
SMS-TX401-001	FR 15	25/15	43
SMS-TX401-001	FR 16.5	25/15	50
SMS-TX401-003	FR 17.5	35/20	39
SMS-TX401-003	FR 18.5	25/20	43
SMS-TX401-003	FR 20	25/20	51
SMS-TX401-003	FR 22	25/20	39
SMS-TX401-003	FR 23	25/20	41
SMS-TX401-003	FR 25	25/20	51
SMS-TX401-003	FR 27.5	25/20	47
SMS-TX401-003	FR 30	35/25	37
SMS-TX401-003	FR 32	35/25	41
SMS-TX401-003	FR 35	35/25	52
SMS-TX401-003	FR 40	35/30	44
SMS-TX401-004	FR 45	45/40	36
SMS-TX401-004	FR 50	45/40	44

Other dimensions on request.
HD=heavy design, LD=light design

Slotted Apertures (SLS/STS)

Part No.	Aperture size	Total thickness/ Wear thickness (mm)	Relative open area (%)
SMS-TX401-002	SL/ST 1 x12	30/8	21%
SMS-TX401-002	SL/ST 1.25x12	30/10	23%
SMS-TX401-002	SL/ST 1.5x12	30/11	25%
SMS-TX401-002	SL/ST 1.8x12	30/11	27%
SMS-TX401-002	SL/ST 2 x16	30/11	25%
SMS-TX401-002	SL/ST 2 x16/37	30/11	27%
SMS-TX401-002	SL/ST 2.5x16	30/11	27%
SMS-TX401-004	SL/ST 2.5x25HD	45/30	14%
SMS-TX401-002	SL/ST 3 x16	30/12	28%
SMS-TX401-002	SL/ST 3 x16HD	30/12	28%
SMS-TX401-002	SL/ST 3.5x18	30/7	37%
SMS-TX401-002	SL/ST 4x8	30/10	37%
SMS-TX401-002	SL/ST 4x20	30/10	38%
SMS-TX401-002	SL/ST 5x16	30/14	32%
SMS-TX401-002	SL/ST 6x16	30/14	36%
SMS-TX401-002	SL/ST 8x12	30/12	49%
SMS-TX401-001	SL/ST 15x30	25/20	40%
SMS-TX401-001	SL/ST15x35	25/15	42%
SMS-TX401-001	SL/ST16x24	25/15	46%
SMS-TX401-001	SL/ST16x25	23/13	49%
SMS-TX401-002	SL/ST20x25	30/20	50%
SMS-TX401-002	SL/ST27x55	30/20	51%

Other dimensions on request.
HD=heavy design, LD=light design
SLS = With flow, STS = Cross flow

To avoid damage to the Trellex TCO PU Cloth, U-cappings on longitudinal supports are required. See next page.

Trellex Tension - accessories

Trellex U-cappings

Trellex U-cappings are installed on support irons in screens with tensioned decks. U-cappings are necessary to avoid damage to the cloth or deckframe. Fits most common support iron widths.



Trellex U-cappings RU

Part No.	Part Description	Weight (kg/m)	Roll length (m)	Rubber Quality
2238820	SM-ACC CAPPING U7/6 20	0.33	20	EPDM 70Sh-A
2238830	SM-ACC CAPPING U9/9 20	0.50	20	EPDM 70Sh-A
2872330	SM-ACC CAPPING U9/15 20	0.54	20	EPDM 70Sh-A
2332850	SM-ACC CAPPING U13/17 20	1.20	20	EPDM 70Sh-A
2238860	SM-ACC CAPPING U16/25 20	2.30	20	EPDM 70Sh-A

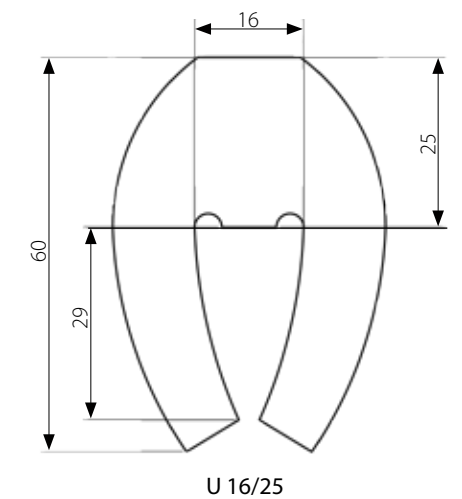
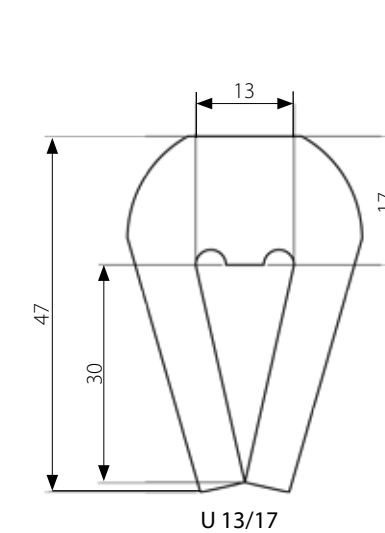
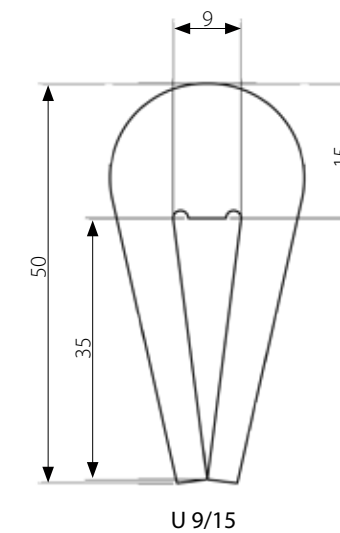
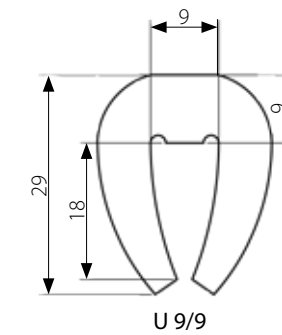
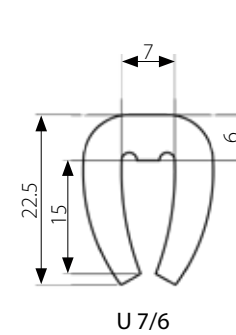

Trellex Tension - accessories

Trellex NH Centre Hold Down

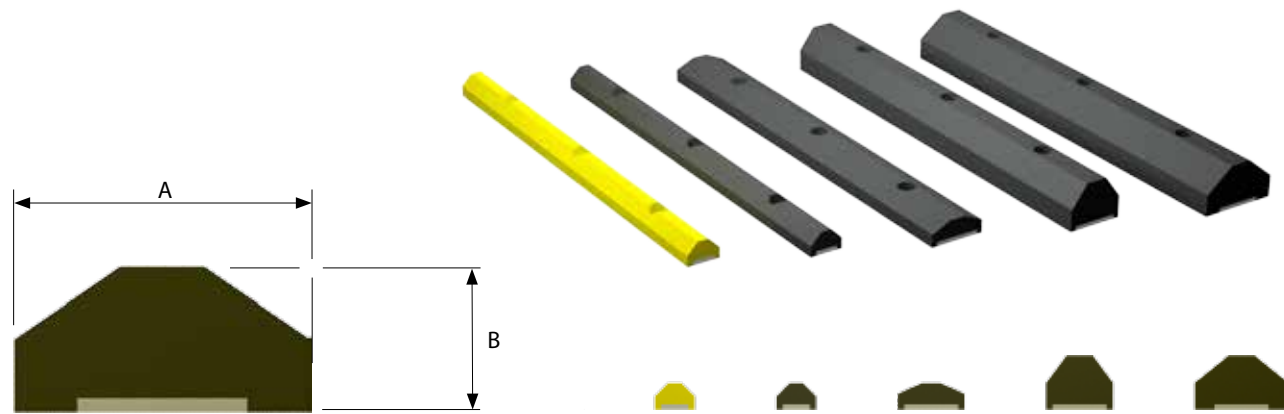

Part No. *	Part Description	Weight (kg)	A (mm)	B (mm)	Length (mm)	Material
6670084-1000	SM-ACC NH-PU 75-50-1000	7.20	75	50	1000	PU
6670084-1200	SM-ACC NH-75-50-1200-PU	8.60	75	50	1200	PU
6670084-1500	SM-ACC NH-PU 75-50-1500	10.80	75	50	1500	PU
2328870-1000	SM-ACC NH-75-50-1000	8.2	75	50	1000	T60
2328870	SM-ACC NH-75-50-1200	7.9	75	50	1200	T60
2328880	SM-ACC NH-75-50-1500	14.4	75	50	1500	T60
2328890-1000	SM-ACC NH-100-50-1000	9.0	100	50	1000	T60
2328890	SM-ACC NH-100-50-1200	10.5	100	50	1200	T60
2328900	SM-ACC NH-100-50-1500	15.0	100	50	1500	T60
2328910-1000	SM-ACC NH-125-50-1000	8.8	125	50	1000	T60
2328910	SM-ACC NH-125-50-1200	15.0	125	50	1200	T60
2328920	SM-ACC NH-125-50-1500	20.1	125	50	1500	T60
2881400	SM-ACC NH-125-100-1000	15.0	125	100	1000	T60
2881410	SM-ACC NH-125-100-1200	17.5	125	100	1200	T60
2881420	SM-ACC NH-125-100-1500	27.6	125	100	1500	T60
2970710	SM-ACC NH-175-50-1200	20.8	175	50	1200	T60
2970720	SM-ACC NH-175-50-1500	25.9	175	50	1500	T60
2970760	SM-ACC NH-175-100-1000	23.3	175	100	1000	T60
2970740	SM-ACC NH-175-100-1200	28.0	175	100	1200	T60
2970750	SM-ACC NH-175-100-1500	40.6	175	100	1500	T60

All NH and NHS Hold Downs can be tailored to required lengths and drillpattern.
(For NHS, drillpattern can not be changed.)

Standard drilling M16 but M12 and M20 can be available upon request.

Trellex Tension - accessories

Trellex NHS Centre Hold Down

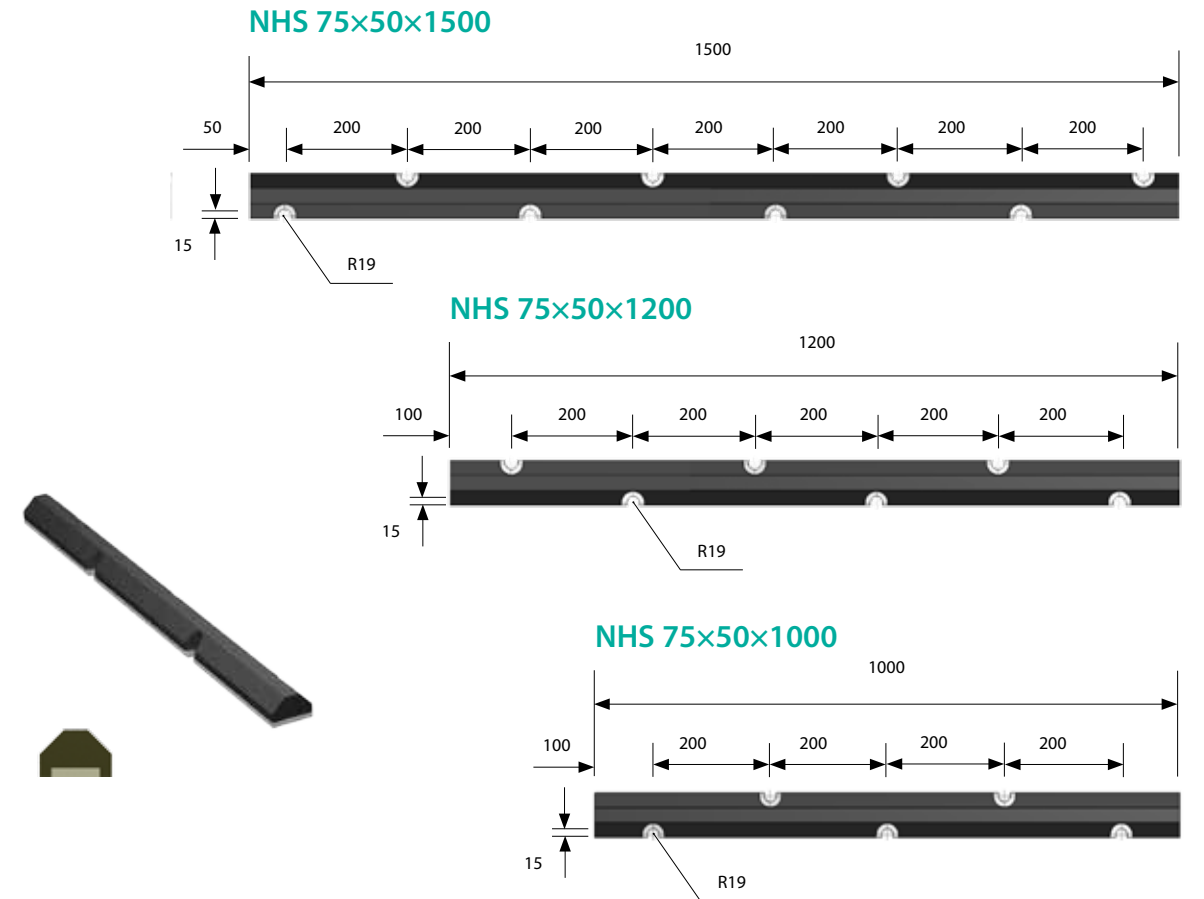

Trellex NHS Centre Hold Down

Part No.	Description	Dimension (mm)	Hook Bolt (Qty)	Material	Weight (kg/each)
613166	Centre Hold Down - NHS	75x50x1000	5	T60	6.8
613158	Centre Hold Down - NHS	75x50x1200	6	T60	8.2
553024	Centre Hold Down - NHS	75x50x1500	8	T60	12.3

Trellex NHS Hook Bolt

Part No.	Description	Dimension (mm)	Weight (kg/each)
2247350	NHS Hook Bolt	M16x200	0.42



ES and CVB screens - tension deck accessories

Part No.	Description	Dimension (mm)	Material	Weight (kg/each)
MM0392741	SM-ACC CLOTH-FASTENING-BAR	24x135x1219	PU 90 Sh-A	8.4
N32700200	SM-ACC CLOTH-FASTENING-WEDGE		PU 90 Sh-A	0.8

Trellex Tension - accessories

Trellex NH Centre Hold Down

ES and CVB screens - tension deck accessories

Trellex NHS Centre Hold Down details

Part No.	Description	Dimension (mm)	Material	Weight (kg/each)
MM0392741	SM-ACC CLOTH-FASTENING-BAR		PU 90 Sh-A	8.4
N32700200	SM-ACC CLOTH-FASTENING-WEDGE	60x60x195	PU 90 Sh-A	0.8

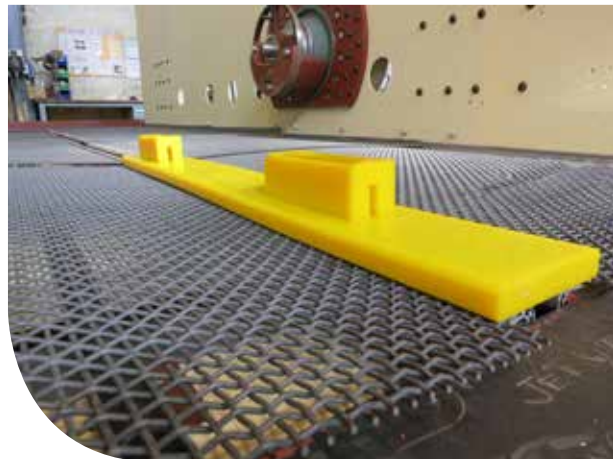

WIRE MEDIA

Trellex PCL

Only available in North America/Canada

Trellex PCL (Poly-Clean) is the latest innovation in screening media technology designed to improve your aggregate production.

Maximize screening efficiency

Trellex PCL wire media is the solution you have been waiting for. It enables you to screen your material efficiently even in the most demanding conditions. Even when your feed material is damp and sticky or prone to pegging, Trellex PCL will screen it and produce a cleaner product.

Combining the wear-resistant properties of polyurethane with the open area of

wire media, Trellex PCL provides up to 30% increased wear life and generally 20% more capacity compared to classic wire media.

Dual durometer technology

Trellex PCL screening media has a flexible inner core that allows greater vibration of individual wires. This inhibits buildup of material over the screening surface, preventing blinding and increasing the efficiency of the deck. The flexible inner core is capped with a wear-resistant layer that maximizes the life of the media.

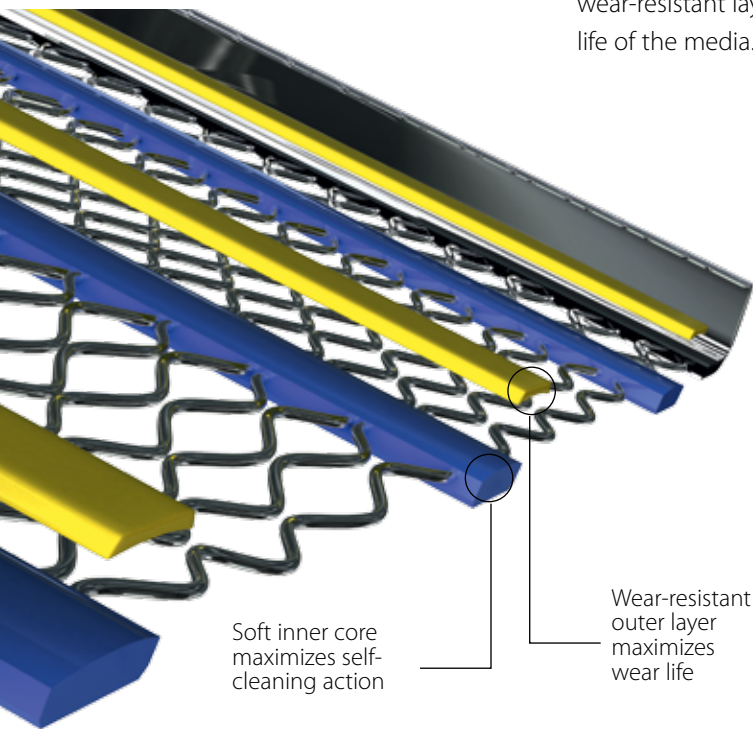

Soft inner core maximizes self-cleaning action

Wear-resistant outer layer maximizes wear life

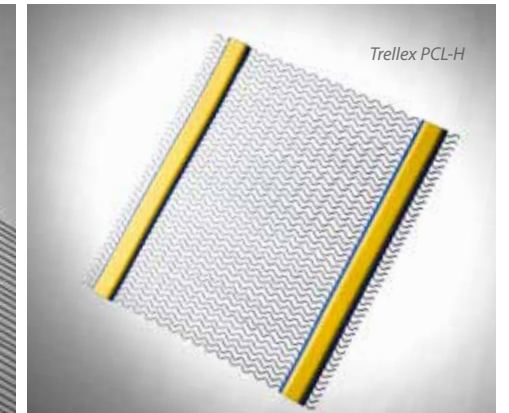
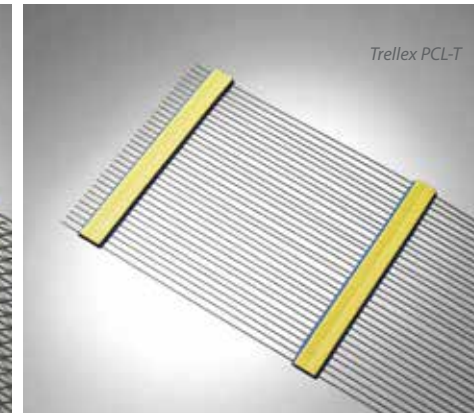
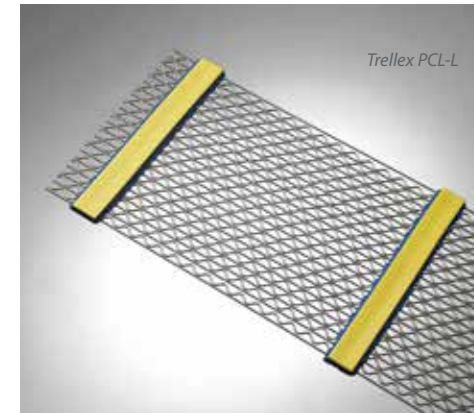
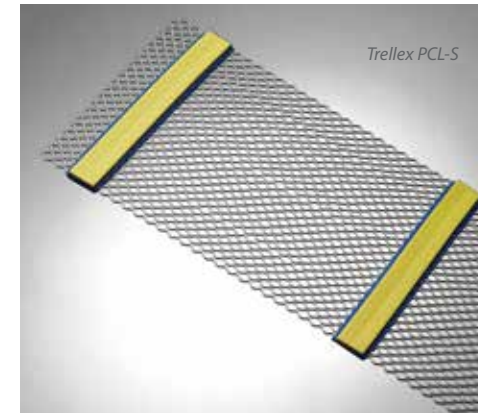

Five weave configurations

For optimum performance, Metso offers Trellex PCL in five unique configurations:

Trellex PCL-S

- Exceptional cleaning ability
- Suited for applications with a high percentage of near-size material that is prone to pegging or blinding

Trellex PCL-L

- Capable of withstanding greater bed depths and loads
- Accurate sizing

Trellex PCL-T

- Maximum open area
- Rapid removal of fine material
- Longer wear life than traditional Piano wire screens

Trellex PCL-H

- High open area
- Removes fine material while retaining accurately sized clean material

Trellex PCL-HD

- Suitable for larger applications up to 4"
- Reduces/eliminates blinding and pegging rapid removal of fine material
- Utilizes double wires to accommodate larger feed size

Wear indicator

The dual durometer polyurethane strips let you monitor wear life and plan for future change outs, eliminating unexpected shutdowns and product contamination.

Ultraloy

Ultraloy, developed by Metso specifically for aggregate screening applications, provides longer wear life than other alloys used in the industry. Ultraloy combines abrasion resistance with ductility, a key quality in the aggregate screening environment.

Astroloy stainless steel

Astroloy stainless steel can be used in high-abrasive applications or with excessively sticky material. Astroloy is a full hard stainless steel, whereas most other stainless alloys being regarded as softer. The wear surface of Astroloy remains smooth throughout its service life, preventing material from adhering to it a key benefit when combined with Metso Poly-Clean.

Hooks

Wide choice of complementary hooks are available, see page 187.

Two types of Trellex PCL – HiPer Life and HiPer Clean

HiPer Life is designed to provide maximum wear life. Same open area as classic wire but with an increased wear life up to 50%.

HiPer Clean is designed to provide maximum screening efficiency and throughput. A greater open area combined with a self-cleaning action for eliminating pegging and blinding results increases the throughput with up to 50%.

HiPer Life specifications

Opening	HiPer Life
1/16	0.041
5/64	0.047
3/32	0.054
1/8	0.080
5/32	0.080
3/16	0.092
7/32	0.092
1/4	0.105
9/32	0.120
5/16	0.135
3/8	0.162
7/16	0.162
1/2	0.162
9/16	0.162
5/8	0.192
11/16	0.192
3/4	0.192
7/8	0.250
1	0.250
1 1/8	0.250
1 1/4	0.250
1 1/2	0.312
1 5/8	0.312
1 3/4	0.312
2	0.312

HiPer Clean specifications

Opening	HiPer Clean
1/16	0.041
5/64	0.047
3/32	0.047
1/8	0.054
5/32	0.063
3/16	0.072
7/32	0.072
1/4	0.080
9/32	0.080
5/16	0.092
3/8	0.105
7/16	0.120
1/2	0.120
9/16	0.135
5/8	0.135
11/16	0.148
3/4	0.162
7/8	0.162
1	0.192
1 1/8	0.192
1 1/4	0.192
1 1/2	0.207
1 5/8	0.207
1 3/4	0.250
2	0.250



Wide choice of complementary hooks

Available in a wide range, other hooks on request.

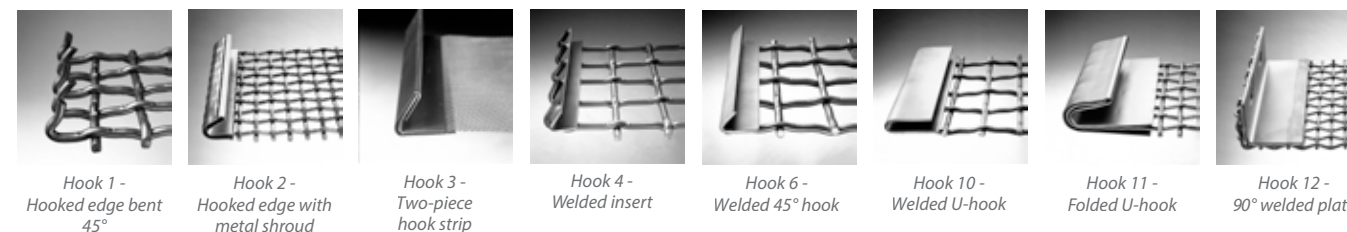

Hook 1 - Hooked edge bent 45°
 Hook 2 - Hooked edge with metal shroud
 Hook 3 - Two-piece hook strip
 Hook 4 - Welded insert
 Hook 6 - Welded 45° hook
 Hook 10 - Welded U-hook
 Hook 11 - Folded U-hook
 Hook 12 - 90° welded plate

WIRE MEDIA

Trellex CLS

Only available in North America/Canada

We offer a complete range of openings, wire diameters, metal and weave types enabling us to provide you with the correct product for your application.

For applications demanding maximum productivity and service, ask for Trellex CLS (classic wire) screening media from Metso.

- Available with complete range of hook configurations
- High availability

Selection available in North America/Canada

Square aperture (")	Wire diameter (")	Open area (%)
4	0.500	79
3	0.500	73.5
2-1/2	0.500	72.4
2-1/2	0.375	75.6
2-1/4	0.375	73.4
2	0.500	64
2	0.375	70.9
1-3/4	0.375	67.8
1-1/2	0.375	64
1-1/2	0.3125	68.5
1-1/4	0.3125	64
1-1/4	0.250	69.4
1-1/8	0.3125	67
1 1/8	0.250	61
1	0.3125	58
1	0.250	64
7/8	0.250	60.5
7/8	0.192	63.3
3/4	0.250	56.3
3/4	0.192	63.4
5/8	0.192	58.5
9/16	0.192	55
1/2	0.192	52.2
1/2	0.162	57.1
7/16	0.162	53.2
3/8	0.162	48.7
3/8	0.135	54.1
5/16	0.135	48.8
1/4	0.120	45.6
1/4	0.105	49.6
3/16	0.092	45.1
3/16	0.080	49.1
5/32	0.080	43.5
1/8	0.080	37.2
1/8	0.063	44.2

Selection of standard openings

We offer a range from 2 to 90 mm. Find here a selection of the most common used square apertures. Other mesh sizes and styles on request.

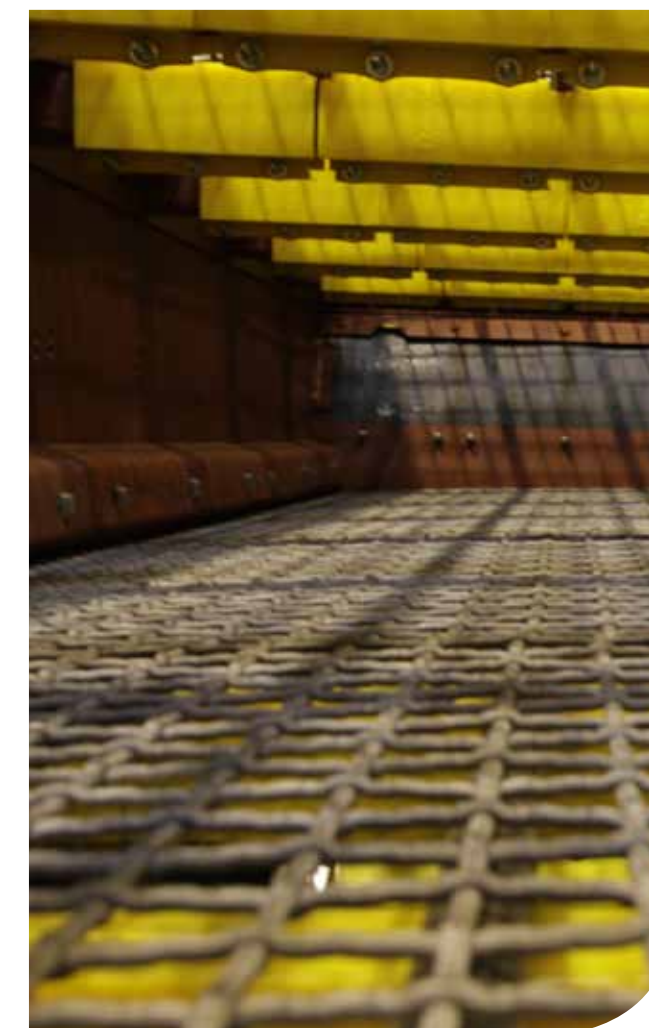

Tension system – installation

Tensioned media templates for Metso CVB/ES screens

ES and CVB screens - tension deck details

Cloth length (mm)	Cloth width (mm)	Overall Hooks (SPA) (mm)	Hook Style	Overlap, when	Remark	ES/CVB 20X			ES/CVB 30X		
						Wire cloth	TFX 3.5-8	TCO-RU	Wire cloth	TFX 3.5-8	TCO-RU
1220	n/a	1842	Open (30°)	Opening < 10x10 mm		4			5		
1220	1690	1805	AUD	Always	Prepared for NHS		4			5	
1220	1690	1810	AUD	Thickness < 10 mm	Prepared for NHS			4			5

Cloth length (mm)	Cloth width (mm)	Overall Hooks (SPA) (mm)	Hook Style	Overlap, when	Remark	ES/CVB 40X			ES/CVB 50X		
						Wire cloth	TFX 3.5-8	TCO-RU	Wire cloth	TFX 3.5-8	TCO-RU
1220	n/a	1204	Open (30°)	Opening < 10x10 mm	Hook down in center	5+5 *			6+6 *		
1220	1072	1180	AUD + CM	Always	Hook down in center		5+5			6+6	
1220	1078	1186	AUD + CM	Thickness < 15 mm	Hook down in center			5+5 **			6+6 **

Cloth length (mm)	Cloth width (mm)	Overall Hooks (SPA) (mm)	Hook Style	Overlap, when	Remark	ES/CVB 60X		
						Wire cloth	TFX 3.5-8	TCO-RU
1220	n/a	1511	Open (30°)	Opening < 10x10 mm	Hook down in center	6+6 *		
1220	1360	1480	AUD + CM	Always	Hook down in center		6+6	
1220	1368	1488	AUD + CM	Thickness < 15 mm	Hook down in center			6+6 **

* Cloth left hand/right hand with overlap (<10x10mm opening)

** Cloth left hand/right hand when cloth thickness <10mm

Centre Hold Down Details

Part No.	Description	ES/CVB 20X			ES/CVB 30X			ES/CVB 40X			ES/CVB 50X			ES/CVB 60X		
		Wire cloth	TFX 3.5-8	TCO-RU	Wire cloth	TFX 3.5-8	TCO-RU	Wire cloth	TFX 3.5-8	TCO-RU	Wire cloth	TFX 3.5-8	TCO-RU	Wire cloth	TFX 3.5-8	TCO-RU
613158	SM-ACC NHS-75-50-1200		4	4		5	5									
2247350	SM-ACC J-BOLT M16x200		24	24		30	30									
MM0392741	SM-ACC CLOTH-FASTENING-BAR				5	5	5	6	6	6	6	6	6	6	6	6
N32700200	SM-ACC CLOTH-FASTENING-WEDGE				10	10	10	12	12	12	12	12	12	12	12	12

Tension system – installation

Tensioned media templates for Metso Classic CVB screens

CVB screens - tension deck details

Cloth length (mm)	Cloth width (mm)	Overall Hooks (SPA) (mm)	Hook Style	Overlap, when	Remark	CVB 1540			CVB 1845			CVB 2050			
						Wire cloth	TFX 3.5-8	TCO-RU	Wire cloth	TFX 3.5-8	TCO-RU	Wire cloth	TFX 3.5-8	TCO-RU	
1350	1470	1470	Open (30°)	Opening < 10x10 mm		3									
1350	1330	1450	AUD	Thickness < 10 mm	NHS Hold down			3							
1350	1325	1445	AUD	Always	NHS Hold down			3							
1140	1760	1760	Open (30°)	Opening < 10x10 mm					4						
1140	1625	1745	AUD	Thickness < 10 mm	NHS Hold down					4					
1140	1620	1740	AUD	Always	NHS Hold down					4					
1250	1960	1960	Open (30°)	Opening < 10x10 mm								4			
1250	1820	1940	AUD	Thickness < 10 mm	NHS Hold down									4	
1250	1815	1935	AUD	Always	NHS Hold down										4

Cloth length (mm)	Cloth width (mm)	Overall Hooks (SPA) (mm)	Hook Style	Overlap, when	Remark	CVB 2060			CVB 2661		
						Wire cloth	TFX 3.5-8	TCO-RU	Wire cloth	TFX 3.5-8	TCO-RU
1500	1960	1960	Open (30°)	Opening < 10x10 mm		4					
1500	1820	1940	AUD	Thickness < 10 mm	NHS Hold down			4			
1500	1815	1935	AUD	Always	NHS Hold down			4			
1525	1254	1254	Open (30°)	Opening < 10x10 mm					4		
1525	1120	1240	AUD	Thickness < 10 mm							4
1525	1115	1235	AUD	Always							4

Centre Hold Down Details

Part No.	Description	CVB 1540			CVB 1845			CVB 2050			CVB 2060			CVB 2661		
		Wire cloth	TFX 3.5-8	TCO-RU	Wire cloth	TFX 3.5-8	TCO-RU	Wire cloth	TFX 3.5-8	TCO-RU	Wire cloth	TFX 3.5-8	TCO-RU	Wire cloth	TFX 3.5-8	TCO-RU
613166	SM-ACC NHS-75-50-1000				4	4										
613158	SM-ACC NHS-75-50-1200		3	3				4	4							
553024	SM-ACC NHS-75-50-1500									4	4					
2247350	SM-ACC J-BOLT M16x200		18	18		20	20		24	24		32	32			
Screen part	Center hold down wedge locking, L=1525													4	4	4

Tension system – installation

Tensioned media templates for Metso TS screens

TS screens - tension deck details

Cloth length (mm)	Cloth width (mm)	Overall Hooks (SPA) (mm)	Hook Style	Overlap, when	Remark	TS2.X			TS3.X		
						Wire cloth	TFX 3.5-8	TCO- RU	Wire cloth	TFX 3.5-8	TCO- RU
915	1490	1490	Open (30°)	Opening < 10x10 mm		6					
915	1350	1470	AUD	Always			6				
915	1345	1465	AUD	Thickness < 10 mm				6			
1000	1795	1795	Open (30°)	Opening < 10x10 mm					6		
1000	1650	1770	AUD	Always	NHS Hold down					6	
1000	1640	1760	AUD	Thickness < 10 mm	NHS Hold down						6

Cloth length (mm)	Cloth width (mm)	Overall Hooks (SPA) (mm)	Hook Style	Overlap, when	Remark	TS4.X			TS5.X		
						Wire cloth	TFX 3.5-8	TCO- RU	Wire cloth	TFX 3.5-8	TCO- RU
1000	1177	1177	Open (30°)	Opening < 10x10 mm	Hook down in center	6+6*					
1000	1047	1167	AUD + CM	Always	Hook down in center		6+6				
1000	1056	1172	AUD + CM	Thickness < 15 mm	Hook down in center			6+6**			
1360	1177	1177	Open (30°)	Opening < 10x10 mm	Hook down in center				6+6*		
1360	1047	1167	AUD + CM	Always	Hook down in center					6+6	
1360	1056	1172	AUD + CM	Thickness < 15 mm	Hook down in center						6+6**

* Cloth left hand/right hand with overlap (<10x10mm opening)

** Cloth left hand/right hand when cloth thickness <10mm

Centre Hold Down Details

Part No.	Description	TS2.X			TS3.X			TS4.X			TS5.X		
		Wire cloth	TFX 3.5-8	TCO- RU	Wire cloth	TFX 3.5-8	TCO- RU	Wire cloth	TFX 3.5-8	TCO- RU	Wire cloth	TFX 3.5-8	TCO- RU
613166	SM-ACC NHS-75-50-1000				6	6							
2247350	SM-ACC J-BOLT M16x200				30	30							
Screen part	Center hold down wedge locking, L=1000						6				6		
Screen part	Center hold down wedge locking, L=1360							6				6	

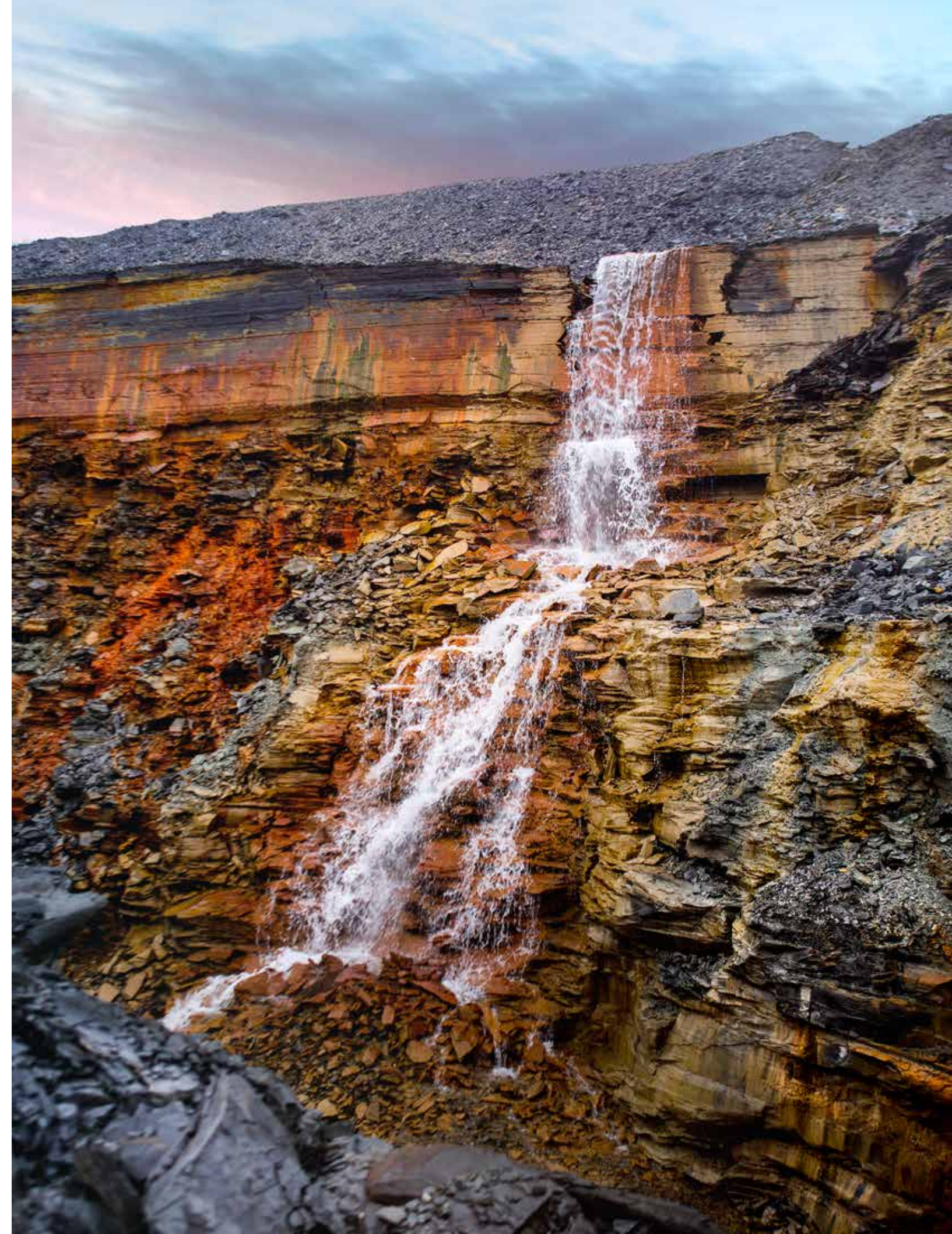



Panel systems to maximize uptime and reduce cost



PANEL SYSTEM

Panel system

Metso Panel systems include a variety of options for coarse to intermediate screening. The system consists of a self-supporting screening panel with an integral steel and cord reinforcement vulcanized within each panel. We offer customized screen panels for any screen and fastening system as well as innovative and optimized module panel systems. Metso panel system offers around-the-clock operation - maximum uptime and lowest cost per tonne.

PANEL SYSTEM

Trellex MP

Designed for round-the-clock operations - maximum uptime and lowest cost per tonne

Trellex MP gives you the best of both worlds by combining the flexibility of a modular system with exceptional strength and durability.

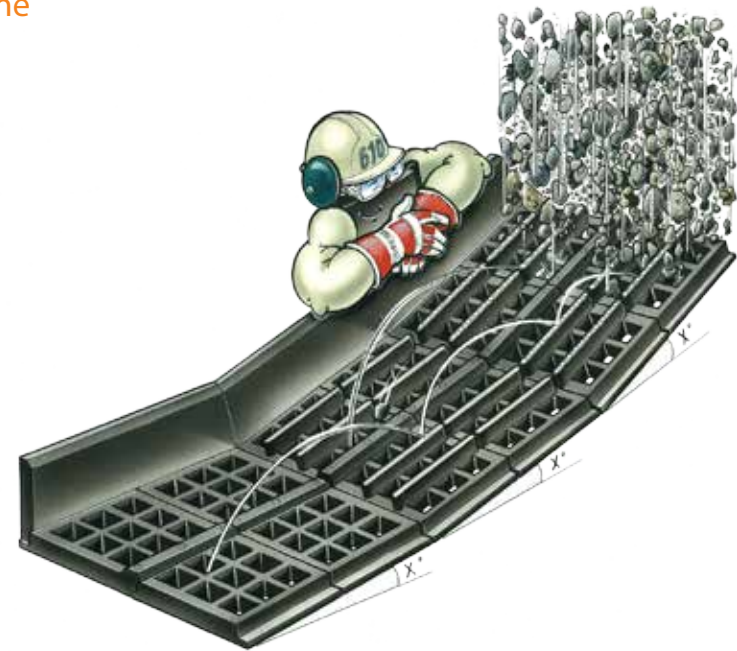

Unique modular panel

The Trellex MP system is designed to manage high loads and deliver improved capacity through its optimized open area design. The modular panels are easy to handle and can easily be kept in stock, making them quickly available when needed.

Skid-bars

The Trellex MP system with skid-bars improves your capacity and increases uptime as bigger lumps are lifted from the surface, allowing undersized material to pass easier and more efficiently. The skid-bar heights are standardized to 20 or 60 mm, depending on panel thickness.

Patented reinforcement system, CISB

The patented reinforcement system (ceramic elements integrated in the skid-bars), ensures maximum performance, capacity and longevity. The CISB system guarantees at least 30% longer uptime (in some cases even double) with the same high capacity. The reinforcement system is available for the 70 and 80 mm thick panels.

Multi-slope screen adaption

A common problem when installing thick panels on a multi-slope screen is interference between two panels due to inclination changes. Normally, the nominal length needs to be shorter

than the actual stringer lengths. With Trellex MP this is not a problem, as all transversal sides are chamfered to manage individual inclination changes up to 10°. Skid bars are also adaptable to inclination changes and recessed fixing standardizes the height over the stringers. And you can always combine thicker panels at the feed end with thinner panels at the discharge end.

Wear material for best performance

There are several material options for optimal performance. T60 is the standard impact- and wear-resistant rubber. Choose T60S for extra long wear-resistance in high-load low impact application.



Trellex MP standard panel

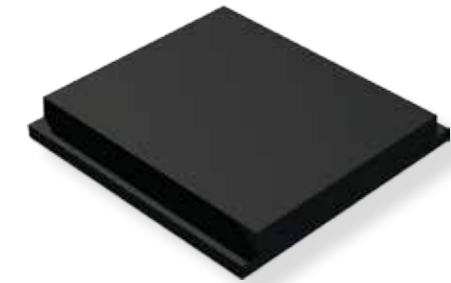

Trellex MP impact panel



Trellex MP standard panels with skid-bars

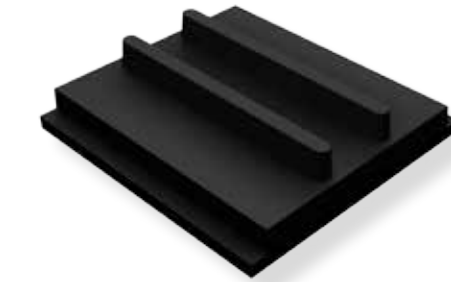

Trellex MP impact panel with skid-bars



Trellex MP with the patented CISB system. CISB can double the lifetime compared to a flat surface and still maximize capacity



Trellex MP impact panel with CISB system

Installation

The system is bolted down to longitudinal rails with center hold downs, optimized to ensure a flat deck on top of the skid bars.

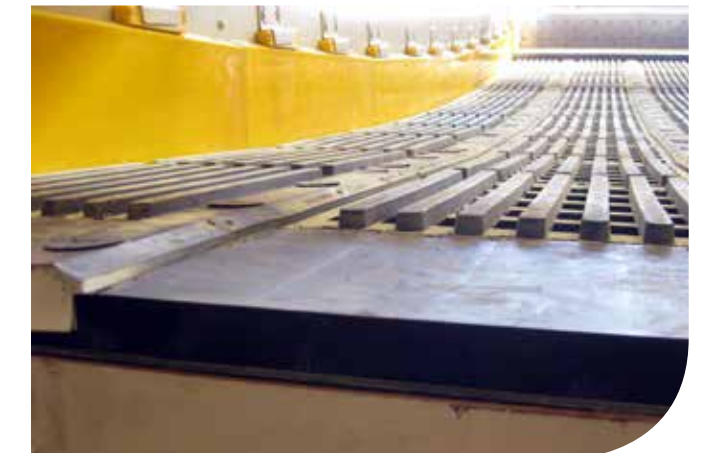

Trellex MP

Trellex 610MP module range

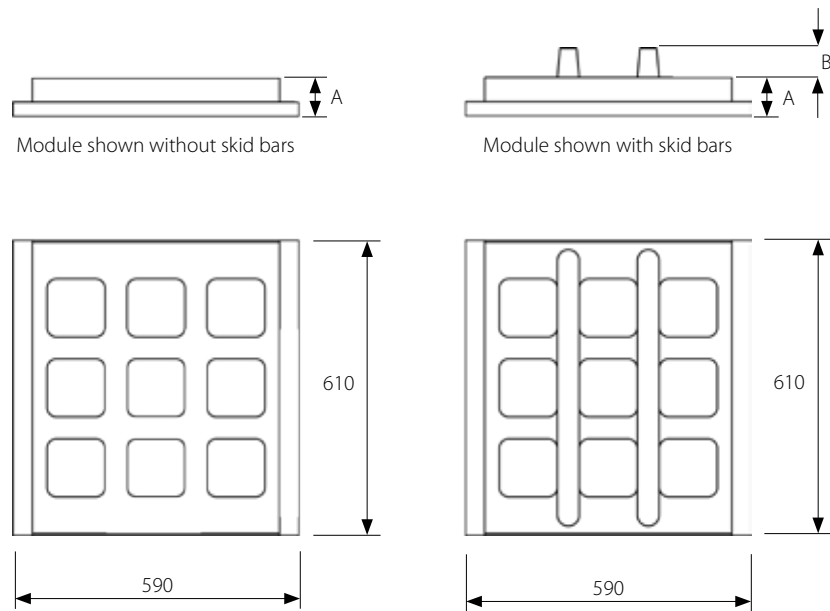

Build height 55

Hole type	Module weight (kg)	Thickness screen area (mm)	Apertures per panel	Relative open area (%)	Effective open area (%)	Min web thickness with flow (mm)	Min web thickness cross flow (mm)	Build height A (mm)	Skid bar height B (mm)	Part No.
SLS25x69M	25.6	55	45	32.9%	21.6%	28	30	55	0	MM0424822
SLS30x69M	26	55	40	34.8	23	30	30	55	0	MM0320525
SLS30x69M	28.4	55	40	34.8	23	30	30	55	20	MM0320526
SLS38x110M	25.8	55	21	37.3	24.4	30	55	55	0	MM0320502
SLS38x110M	27.9	55	21	37.3	24.4	30	55	55	20	MM0320504
SLS50x100M	25.6	55	18	40.3	25	30	55	55	0	MM0320474
SLS50x100M	27.4	55	18	40.3	25	30	55	55	20	MM0320475
FR40M	24.9	55	64	45.2	28.5	19	20	55	0	MM0320523
FR40M	26.5	55	64	45.2	25.8	19	20	55	20	MM0320522
FR50M	24.7	55	42	43.5	29.2	31	21	55	0	MM0320501
FR50M	26.6	55	42	43.5	29.2	31	21	55	20	MM0320500
FR60M	25.8	55	25	37.9	25	35	40	55	0	MM0320478
FR60M	27	55	25	37.9	25	35	40	55	20	MM0320459
FR70M	23.8	55	25	51.6	27.9	25	30	55	0	MM0320480
FR70M	25	55	25	51.6	27.9	25	30	55	20	MM0320477
FR75M	25.8	55	16	37.5	25	45	50	55	0	MM0320481
FR75M	27.4	55	16	37.5	25	45	50	55	20	MM0320479

Other apertures on request.
SLS = With flow, STS = Cross flow



Build height 70

Hole type	Module weight (kg)	Thickness screen area (mm)	Apertures per panel	Relative Open Area (%)	Effective Open Area (%)	Min web thickness with flow (mm)	Min web thickness cross flow (mm)	Build height (mm)	Ceramic lining	Skid bar height (mm)	Part No.
SLS38x110HDM	30.3	70	18	32.5	24.4	40	55	70		0	MM0320506
SLS38x110HDM	36.8	70	18	32.5	24.4	40	55	70		60	MM0320507
SLS38x110HDM	38.6	70	18	32.5	24.4	40	55	70	YES	60	MM0320511
FR80M	28.3	70	16	42.7	28.5	40	45	70		0	MM0320516
FR80M	32.2	70	16	42.7	28.5	40	45	70		60	MM0320476
FR80M	33.3	70	16	42.7	28.5	40	45	70	YES	60	MM0320519
C85M	30.1	70	16	37.6	25.2	35.6	40	70		25	MM0419872
SLS80x125	26.9	70	12	50.5	33.3	40	40	70		0	MM0357588
SLS80x125	30.8	70	12	50.5	33.3	40	40	70		60	MM0357587
SLS80x125	31.9	70	12	50.5	33.3	40	40	70	YES	60	MM0354585
FR90M	29.4	70	9+3	36.3	23.9	75	45	70		0	MM0357590
FR90M	32.4	70	9+3	36.3	23.9	75	45	70		60	MM0357589
FR90M	33.1	70	9+3	36.3	23.9	75	45	70	YES	60	MM0332001
FR100M	30.8	70	9	36.7	25.0	65	65	70		25	MM0396682
FR100M	31.8	70	9	36.7	25.0	65	65	70	YES	25	MM0418212
FR100M	29.5	70	9	36.7	25.0	65	65	70		0	MM0320517
FR100M	32.4	70	9	36.7	25.0	65	65	70		60	MM0320520
FR100M	33.1	70	9	36.7	25.0	65	65	70	YES	60	MM0320521
FR150M	28.0	70	9	58.0	35.8	48	48	70		0	MM0320521

Build height 80

Hole type	Module weight (kg)	Thickness screen area (mm)	Apertures per panel	Relative open area (%)	Effective open area (%)	Min web thickness with flow (mm)	Min web thickness cross flow (mm)	Build height (mm)	Ceramic lining	Skid bar height (mm)	Part No.
FR50HD	31	80	36	36.3	25.0	31	35	80		0	MM0400499
FR50HD	32.8	80	36	36.3	25.0	31	35	80		20	ZX11302855
FR60HD	31.4	80	25	37.9	25.0	35	40	80		0	MM0374274
FR60HD	32.5	80	25	37.9	25.0	35	40	80		20	MM0374278
FR110M	30.2	80	9	44.4	30.3	55	55	80		0	MM0320512
FR110M	33.2	80	9	44.4	30.3	55	55	80		60	MM0320515
FR110M	33.8	80	9	44.4	30.3	55	55	80	YES	60	MM0320518
FR115M	29.3	80	9	48.6	33.1	50	50	80		0	MM0320510
FR115M	32.2	80	9	48.6	33.1	50	50	80		60	MM0320509
FR115M	32.9	80	9	48.6	33.1	50	50	80	YES	60	MM0320513
FR120M	28.3	80	9	52.9	36.0	45	45	80		0	MM0320514
FR120M	31.3	80	9	52.9	36.0	45	45	80		60	MM0320505
FR120M	32	80	9	52.9	36.0	45	45	80	YES	60	MM0320524
SLS110x140M	29.6	80	6+3	47.9	32.1	55	55	80		0	MM0380509
SLS110x140M	32.6	80	6+3	47.9	32.1	55	55	80		60	MM0380510

Other apertures on request.
SLS = With flow, STS = Cross flow

Trellex MP

Trellex 610MP module range

Continued from previous page

Build height 55 - Blind modules

Hole Type	Module weight (kg)	Thickness screen area (mm)	Build height (mm)	Quantity of skid bars	Skid bar height (mm)	Part No.
BLIND	31.3	55	55	0	0	MM0320554
BLIND	33.9	55	55	7	20	MM0320541

Build height 70 - Blind modules

Hole Type	Module weight (kg)	Thickness screen area (mm)	Build height (mm)	Quantity of skid bars	Ceramic Lining	Skid bar height (mm)	Part No.
BLIND	36.5	70	70	0		0	MM0320553
BLIND	43	70	70	5		60	MM0320543
BLIND	44.8	70	70	5	YES	60	MM0320542

Build height 80 - Blind modules

Hole Type	Module weight (kg)	Thickness screen area (mm)	Build height (mm)	Quantity of skid bars	Ceramic Lining	Skid bar height (mm)	Part No.
BLIND	40	80	80	0		0	MM0320552
BLIND	43	80	80	5		60	MM0320555
BLIND	43.6	80	80	5	YES	60	MM0320557

Trellex 610MP

Trellex 610MP discharge spouts

Rubber 60°, shore hardness - blind discharge spouts for MP installations



Build height 55, 70, 80

Module width* (mm)	Module length (mm)	Build height (mm)	Module weight (kg)	Part No. (T60)
610	305	55	18	MM0320549
610	305	70	20	MM0320550
610	305	80	22	MM0320551

* Build width on deck.

Trellex MP accessories

Trellex 610MP hold downs

Bolted hold downs

The bolt down system uses nuts and bolts to hold down the panels. A recessed steel-backed rubber sidliner secures the installation.



Metso Global Mining Screens MF/EF/RF/LH

Part No.	Description	Weight (kg)	Length (mm)	Thickness (mm)	610MP Build height (mm)	Steel/rubber hole (mm)	Quantity holes	Hole distribution (mm)
422596.216	MP NH-55-610-100-45-T60-3X20/54	6.4	610	45	55	20/54	3	55-250-250-55
422596.217	MP NH-55-915-100-45-T60-4X20/54	9.8	915	45	55	20/54	4	82.5-250-250-250-82.5
MM0342093	MP NH-70-610-100-100-T60-3X20/54	9.7	610	100	70	20/54	3	55-250-250-55
MM0342094	MP NH-70-915-100-100-T60-4X20/54	14.9	915	100	70	20/54	4	82.5-250-250-250-82.5
MM0344959	MP NH-80-610-100-110-T60-3x20/54	10.3	610	110	80	20/54	3	55-250-250-55
MM0344960	MP NH-80-915-100-110-T60-4x20/54	15.8	915	110	80	20/54	4	82.5-250-250-250-82.5

Alternative drilling - Patterns

Part No.	Description	Weight (kg)	Length (mm)	Thickness (mm)	610MP Build height (mm)	Steel/rubber hole (mm)	Quantity holes	Hole distribution (mm)
MM0384128	MP NH-55-610-100-45-T60-3X20/54	6.4	610	45	55	20/54	3	102-203-203-102
MM0366544	MP NH-55-610-100-45-T60-2X20/54	6.5	610	45	55	20/54	2	152.5-305-152.5
ZX11368229	MP NH-70-610-100-100-T60-3XM18	9.8	610	100	70	20/54	3	102-203-203-102
MM0366541	MP NH-70-610-100-100-T60-2X20/54	9.8	610	100	70	20/54	2	152.5-305-152.5
422596.214	MP NH-55-610-100-45-T60-2X20/40	6.5	610	45	55	20/40	2	147.5-305-157.5
422596.215	MP NH-55-915-100-45-T60-3X20/40	10.0	915	45	55	20/40	3	152.5-305-305-152.5
422596.224	MP-NH-55-610-100-45-T60-4X20/54	6.5	610	45	55	20/54	4	51-203-102-203-51

Blind hold downs

Part No.	Description	Weight (kg)	Length (mm)	Thickness (mm)	610MP Build height (mm)
MM0320559	MP NH-55-610-100-45-T60	6.6	610	45	55
MM0320560	MP NH-55-915-100-45-T60	9.4	915	45	55
MM0320561	MP NH-70-610-100-100-T60	10.3	610	100	70
MM0320562	MP NH-70-915-100-100-T60	15.7	915	100	70
MM0320563	MP NH-80-610-100-110-T60	11.0	610	110	80
MM0320564	MP NH-80-915-100-110-T60	16.7	915	110	80

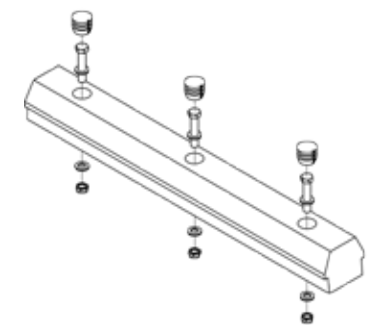

Part No.	Description	Steel/rubber hole (mm)	Module weight (kg)
ML-248025	RUBBERPLUG 60/50-35	20/54	0.1
ML-248024	ML-RUBBERPLUG 45/35-35	20/40	0.03

* Hole distribution on 610 mm NH ==> 55 - 250 - 250 - 55.

** Hole distribution on 915 mm NH mm NH ==> 82.5 - 250 - 250 - 250 - 82.5.

Hole distribution to suit Metso Mining Screen standard - RF/MF.

Trellex MP accessories

Side wall protection

with wedge-down sideliners – chamfer top

- Made to suit angle changes on Multi-Slope Banana screens
- Can be made to fit as feed box sidelinings

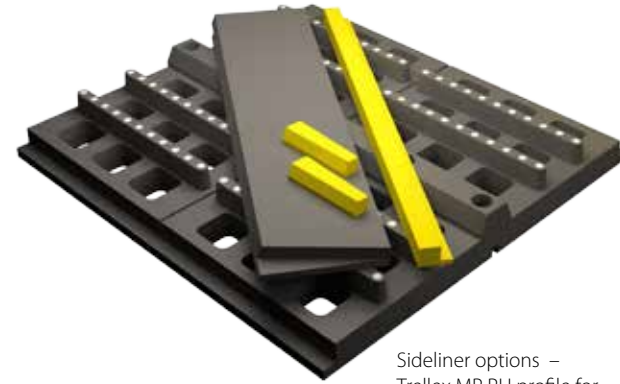

Sideline options –
Trellex MP PU profile for
wedgedown sideliners

For complete partlists please refer to page 104-111.

Ledge angle strips - Build height 55/70/80

Part No.	Description	Comments	Module weight (kg)
MM0320565	MP-ACC-SIDE_STRIP_55-52-1218-PU	Trellex 610MP - Side Wall Strip (BH55)	2.5
MM0320567	MP-ACC-SIDE_STRIP_55-52-1525-PU	Trellex 610MP - Side Wall Strip (BH55)	3.1
MM0320568	MP-ACC-SIDE_STRIP_70-52-1218-PU	Trellex 610MP - Side Wall Strip (BH70)	3.6
MM0320569	MP-ACC-SIDE_STRIP_70-52-1525-PU	Trellex 610MP - Side Wall Strip (BH70)	4.5
MM0320570	MP-ACC-SIDE_STRIP_80-52-1218-PU	Trellex 610MP - Side Wall Strip (BH80)	4.4
MM0320571	MP-ACC-SIDE_STRIP_80-52-1525-PU	Trellex 610MP - Side Wall Strip (BH80)	5.5

PU wedges

Part No.	Description	Remark
6681339	LS-ACC-WEDGE-40-48-32-220-PU75/90-L	(Left hand version)
6681340	LS-ACC-WEDGE-40-48-32-220-PU75/90-R	(Right hand version)

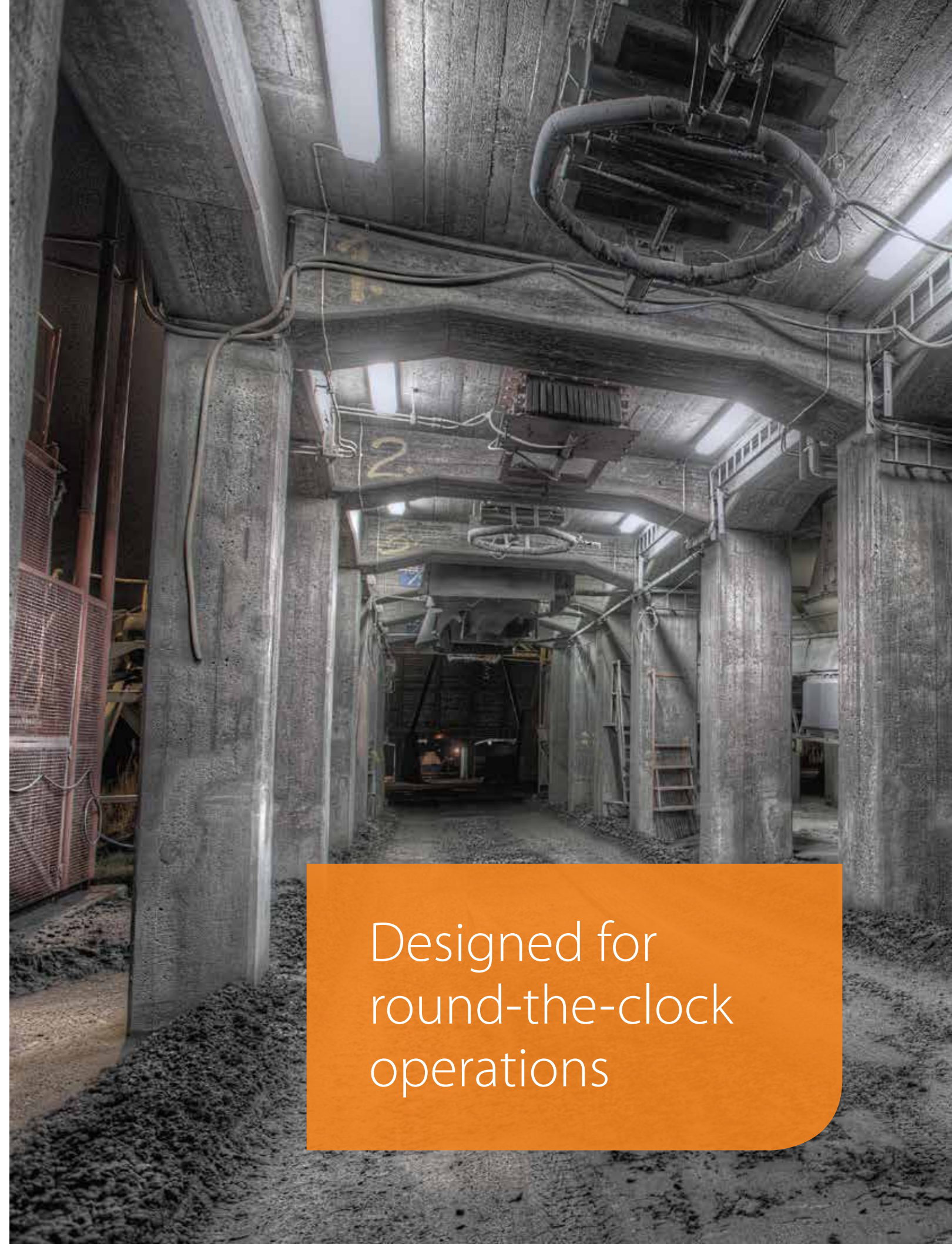

Designed for
round-the-clock
operations

Trellex MP – installation

Installation guidelines

Trellex 610MP – Deck layout example

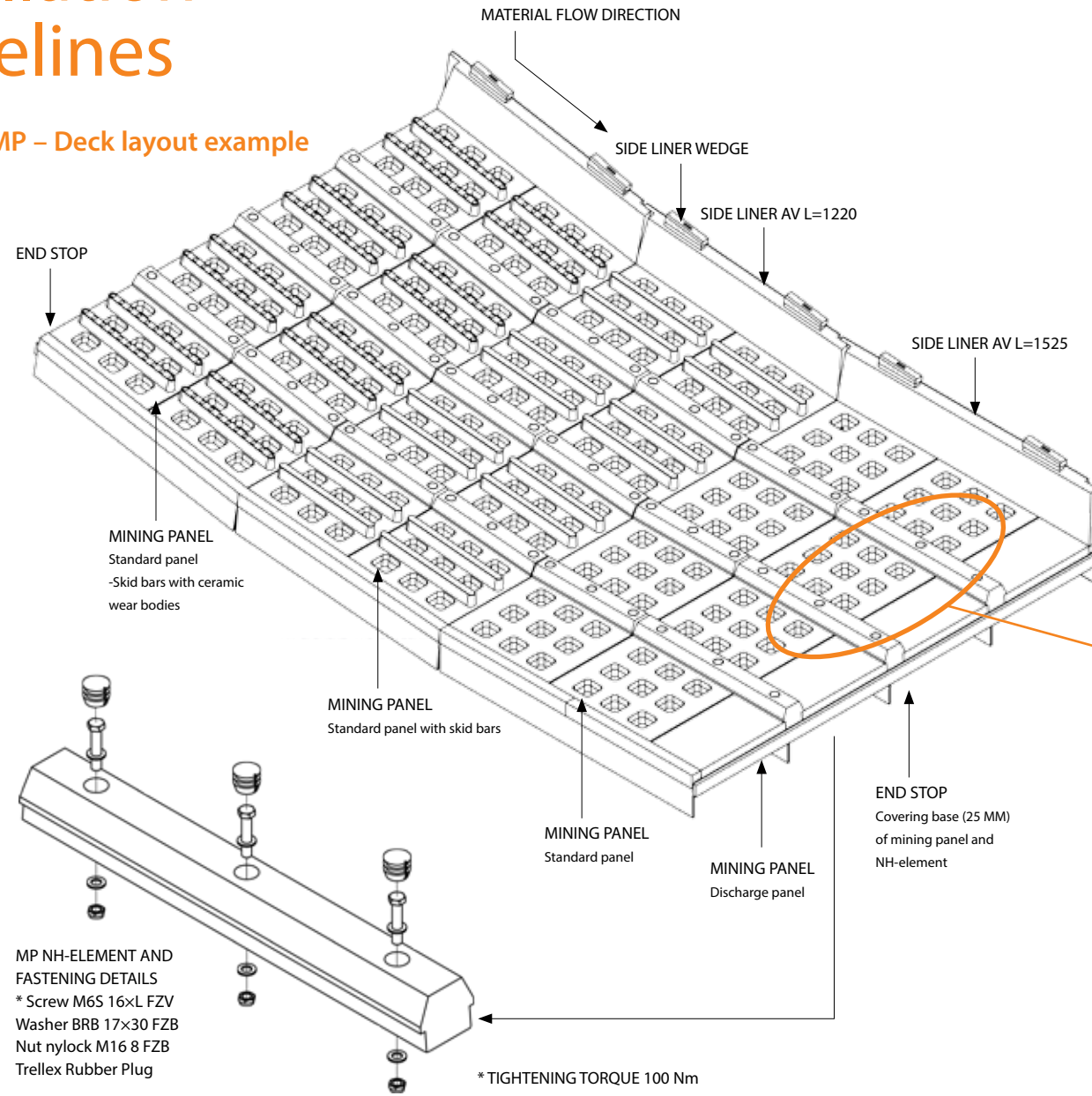

INSTALLATION OF MINING PANEL USING BOLTED MP NH-ELEMENT

Hole diameter through metal stringer: $\varnothing 18 - \varnothing 20$
 Metal stringer support: minimum 75
 C-C between fastening holes: 610 ± 1

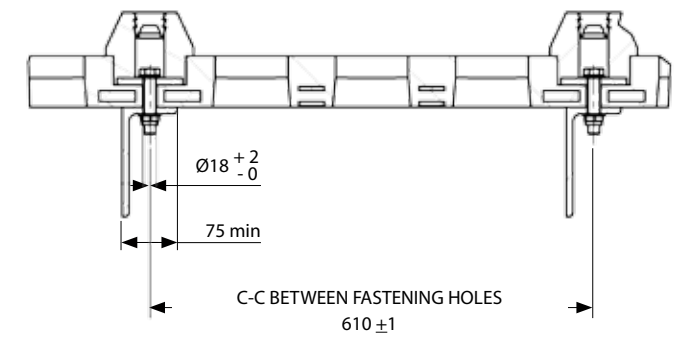
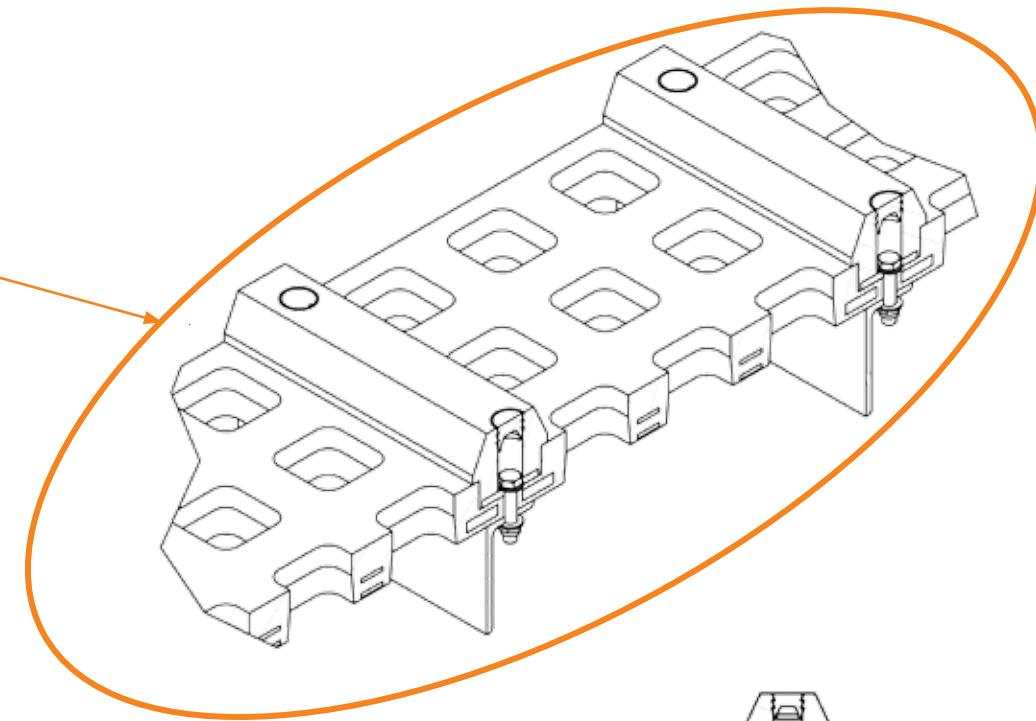

Support frame

Screen nominal width (ft)	Screen nominal width (mm)	Width between side plates – tolerances* (ft/in)	Width between side plates – tolerances* (mm)	Screen deck – apertured length (ft/mm)	Discharge spout – blind length (ft/mm)
4	1220	4' (0/+3/4")	1220 (0/+20)	Multiples of 2' or 610	1' or 305
6	1830	6' (0/+3/4")	1830 (0/+20)	Multiples of 2' or 610	1' or 305
8	2440	8' (0/+3/4")	2440 (0/+20)	Multiples of 2' or 610	1' or 305
10	3050	10' (0/+3/4")	3050 (0/+20)	Multiples of 2' or 610	1' or 305
12	3660	12' (0/+3/4")	3660 (0/+20)	Multiples of 2' or 610	1' or 305
14	4270	14' (0/+3/4")	4270 (0/+20)	Multiples of 2' or 610	1' or 305

**PANEL SYSTEM**

Trellex PCO

Trellex PCO is a self-supporting screening panel made of rubber for demanding applications in coarse and medium screening operations. Aperture shape is designed to minimize the risk of pegging and maximize throughput. The thickest panels also have skid-bars on the upper surface to increase life in coarse applications as bigger lumps are lifted from the surface, allowing undersized material to pass more easily and more efficiently.

- Custom-made rubber panel for demanding applications
- Molded apertures with skid-bars for increased wear life and capacity
- Max panel size 1800x1200 mm (4'x6')
- Standard attachment with side hold-down bars and centre hold-downs or with integrated fixing holes
- Standard build heights 37, 41, 45, 55, 70 and 80 mm

Trellex PCO

Trellex PCO

Available apertures (FR/SLS/STS)

Build height 37 (no skidbars)

Hole type/size A	Thickness screen area B (mm)	Build height B (mm)
FR4	12	37
FR6	15	37
FR8	17	37
FR10	19	37
FR12	21	37
FR14	23	37
FR16	25	37
FR18	25	37
SLS/STS 4x15	15	37
SLS/STS 5x15	18	37
SLS/STS 6x15	20	37
SLS/STS 6x20	13	37
SLS/STS 8x20	14	37
SLS/STS 10x20	20	41
SLS/STS 12x20	18	41

Other apertures on request.
SLS = With flow, STS = Cross flow

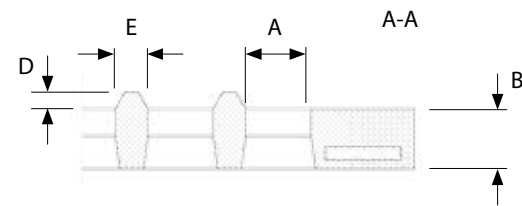

Build height 45

Hole type/size A	Thickness screen area B (mm)	Web thickness with flow E (mm)	Build height B (mm)	Skid bar height D (mm)
SLS/STS 15x20	26	10	45	0
FR20	45	10	45	7.5
FR25	45	12.5	45	8
FR30	45	15	45	9
FR32	45	20.5	45	9
FR35	45	17.5	45	9

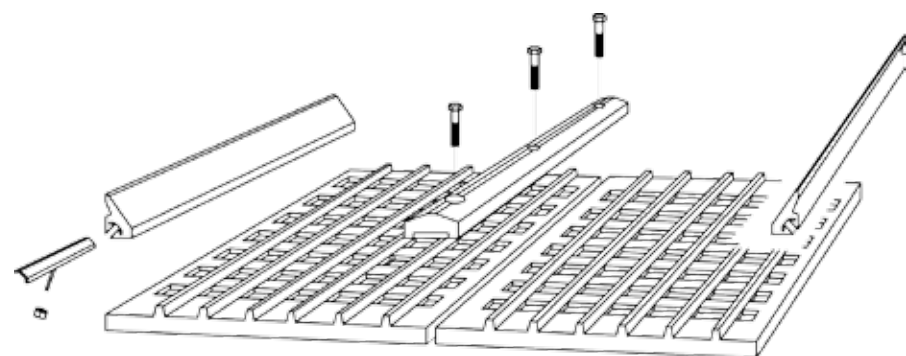

Trellex PCO

Trellex PCO

Available apertures (FR/SLS/STS/C)

Build height 55/70/80

Hole type/size A	Thickness screen area B (mm)	Web thickness with flow E (mm)	Build height B (mm)	Skid bar height D (mm)
SLS/STS 9x20	38		55	0
SLS/STS 9x20	55		55	0
SLS/STS 11x20	28		55	0
SLS/STS 38x110	55	20	55	10
SLS/STS 40x160	55	20	55	10
SLS/STS 50x100	55	25	55	13
FR40	55	20	55	10
FR50	55	25	55	13
FR60	55	30	55	15
FR70	55	35	55	18
FR75	55	37.5	55	19
FR80	70	40	70	20
FR90	70	45	70	23
FR100	70	60	70	50
C75	70	37.5	70	19
C80	70	40	70	20
C85	70	50	70	23
C100	70	60	70	50
C110	70	60/70, 70/80, 80/90	70	75
FR110	80	60/70, 70/80, 80/90	80	75
FR115	80	70/75, 80/85, 90/95	80	75
FR120	80	60, 70, 80	80	75
FR140	80	60, 70	80	75
FR150	80	60, 75	80	75
C120	80	60, 70, 80	80	75
C150	80	60, 75	80	75
C220	80	80, 95	80	0

Other apertures on request.
SLS = With flow, STS = Cross flow
Apertures may differ depending on manufacturing facility.

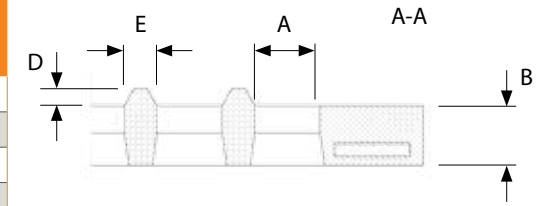

Trellex PCO - accessories

Trellex FL-T Side hold down



Side Hold Down - Fixing details

Part No.	Description	Dimension (mm)	Weight (kg)
2333480	SM-ACC-FL-T-1195	L=1195	6.7
2333485	SM-ACC-FL-T-1220	L=1220	6.7
2934030	SM-ACC-FL-T-1515	L=1515	8.5
6660440	SM-ACC-FL-T BOLT 280-150	L=280	1.4
2934100	SM-ACC-FL-T BOLT 380-150	L=380	1.6
2971410	SM-ACC-FL-T WASHER	Angle washer 50x50x7	0.22

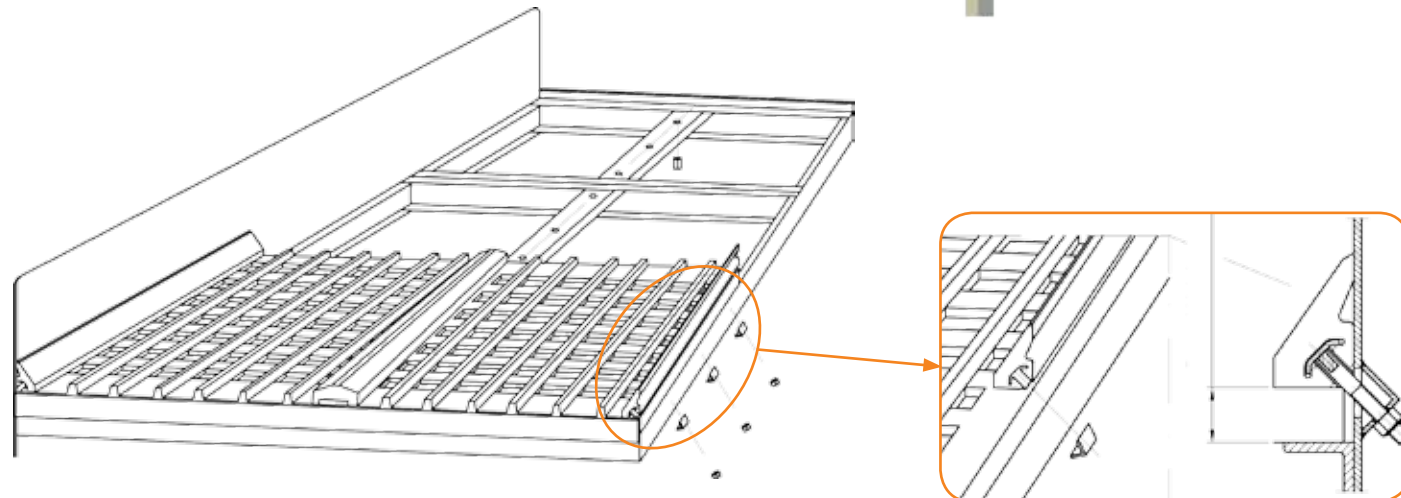
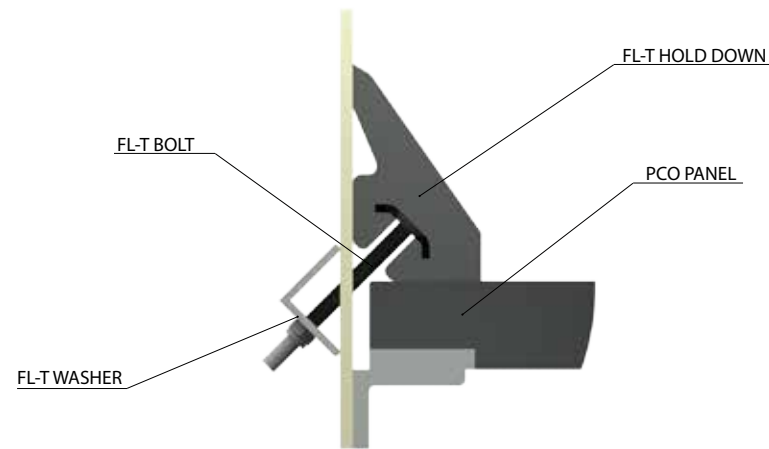

Trellex PCO - accessories

Trellex NH Centre Hold Down

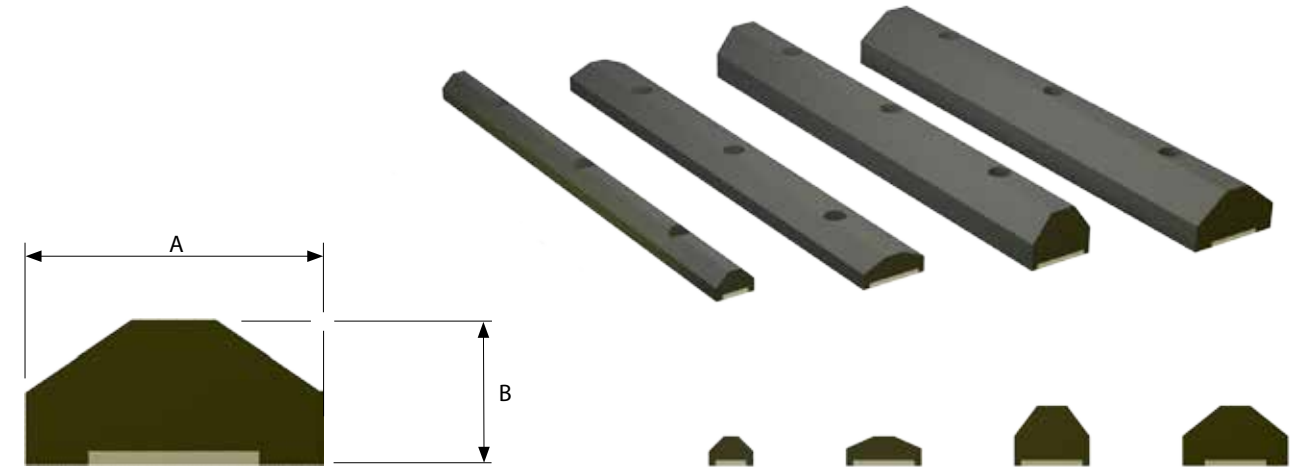

Centre Hold Down

Part No.	Description	Weight (kg)	A (mm)	B (mm)	Length (mm)	Material
2328870-1000	SM-ACC NH-75-50-1000	8.2	75	50	1000	T60
2328870	SM-ACC NH-75-50-1200	7.9	75	50	1200	T60
2328880	SM-ACC NH-75-50-1500	14.4	75	50	1500	T60
2328890-1000	SM-ACC NH-100-50-1000	9.0	100	50	1000	T60
2328890	SM-ACC NH-100-50-1200	10.5	100	50	1200	T60
2328900	SM-ACC NH-100-50-1500	15.0	100	50	1500	T60
2328910-1000	SM-ACC NH-125-50-1000	8.8	125	50	1000	T60
2328910	SM-ACC NH-125-50-1200	15.0	125	50	1200	T60
2328920	SM-ACC NH-125-50-1500	20.1	125	50	1500	T60
2881400	SM-ACC NH-125-100-1000	15.0	125	100	1000	T60
2881410	SM-ACC NH-125-100-1200	17.5	125	100	1200	T60
2881420	SM-ACC NH-125-100-1500	27.6	125	100	1500	T60
2970710	SM-ACC NH-175-50-1200	20.8	175	50	1200	T60
2970720	SM-ACC NH-175-50-1500	25.9	175	50	1500	T60
2970760	SM-ACC NH-175-100-1000	23.3	175	100	1000	T60
2970740	SM-ACC NH-175-100-1200	28.0	175	100	1200	T60
2970750	SM-ACC NH-175-100-1500	40.6	175	100	1500	T60

All NH Centre Hold Downs can be tailored to required length and drill pattern.

GENERAL SCREENING MEDIA ACCESSORIES

General screening media accessories

We offer a range of standard options that enables you to customize your screen according to your needs.

- Cross member protection
- Screen feedbox and discharge spout lining
- Dust control
- Spray nozzles

General screening media accessories

Trellex CMP

Polyurethane modular crossmember protection

Trellex Crossmember protection (CMP) is a replaceable protection liner developed for Metso screens, Nordberg TS and Nordberg CVB. The CMP is designed to reduce exposure to the screen's structural elements and to protect the steel crossmembers from wear. Available in polyurethane, 10 mm (3/8") thickness.

Developed for Metso screens Nordberg TS, ES and CVB.



General screening media accessories

Trellex CMP

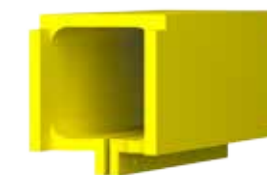

For Metso CVB screens protection

Screen model	Deck frame	Dimension	Quantity (Per kit)	Description	Weight (kg/each)	Part No.
CVB1540	300LS	90x90	1	CMP-CVB1540-LS, L=689	2.3	N69251085
			1	CMP-CVB1540-LS, L=689	2.3	N69251086
			18	CMP-CVB1540/1845-LS, L=300	2.0	N69251087
			12	CMP-CVB1540/1845-LS, L=240	1.9	N69251088
			1	CMP-CVB1540-LS, L=950	5.2	N69251089
			1	CMP-CVB1540-LS, L=502	2.9	N69251090
CVB1540	TENSION	70x70	1	CMP-CVB1540-ST, L=654	2.6	N69251106
			1	CMP-CVB1540-ST, L=654	2.6	N69251117
			24	CMP-CVB1540-ST, L=230	0.9	N69251118
			12	CMP-CVB1540-ST, L=188	0.8	N69251119
			1	CMP-CVB1540-ST, L=838	4.2	N69251120
			1	CMP-CVB1540-ST, L=611	3	N69251121
CVB1845	300LS	90x90	1	CMP-CVB1845-LS, L=839	3	N69251091
			1	CMP-CVB1845-LS, L=839	3	N69251092
			24	CMP-CVB1540/1845-LS, L=300	1.5	N69251087
			12	CMP-CVB1540/1845-LS, L=240	1.2	N69251088
			1	CMP-CVB1845-LS, L=839	4.6	N69251093
			1	CMP-CVB1845-LS, L=839	4.6	N69251094
CVB1845	TENSION	80x80	1	CMP-CVB1845-TENSION, L=808	4.2	N69251122
			1	CMP-CVB1845-TENSION, L=808	4.3	N69251123
			24	CMP-CVB1845-TENSION, L=270	1.2	N69251124
			12	CMP-CVB1845-TENSION, L=245	1.1	N69251125
			1	CMP-CVB1845-TENSION, L=808	4.8	N69251126
			1	CMP-CVB1845-TENSION, L=808	4.8	N69251127
CVB2050	300LS	120x120	1	CMP-CVB2050/60-LS, L=939	3.1	N69251095
			1	CMP-CVB2050/60-LS, L=939	3.1	N69251096
			30	CMP-CVB2050/60-LS, L=300	1.8	N69251097
			6	CMP-CVB2050/60-LS, L=240	1.5	N69251098
			6	CMP-CVB2050/60-LS, L=140	0.8	N69251099
			1	CMP-CVB2050/60-LS, L=939	5.5	N69251100
			1	CMP-CVB2050/60-LS, L=939	5.5	N69251101
			1	CMP-CVB2050/60-LS, L=939	5.5	N69251102
			1	CMP-CVB2050/60-LS, L=939	5.5	N69251103
			1	CMP-CVB2050/60-LS, L=939	3.1	N69251104
			1	CMP-CVB2050/60-LS, L=939	3.1	N69251105
CVB2050	TENSION	100x100	2	CMP-CVB2050/60-TENSION, L=899	3.5	N69251128
			2	CMP-CVB2050/60-TENSION, L=899	3.5	N69251129
			24	CMP-CVB2050/60-TENSION, L=320	1.7	N69251130
			12	CMP-CVB2050/60-TENSION, L=259	1.4	N69251131
			2	CMP-CVB2050/60-TENSION, L=899	6.6	N69251132
			2	CMP-CVB2050/60-TENSION, L=899	6.6	N69251133

Table continues on next page

General screening media accessories

For Metso CVB screens protection

Screen model	Deck frame	Dimension	Quantity (Per kit)	Description	Weight (kg/each)	Part No.
CVB2060	300LS	120x120	1	CMP-CVB2050/60-LS, L=939	3.1	N69251095
			1	CMP-CVB2050/60-LS, L=939	3.1	N69251096
			30	CMP-CVB2050/60-LS, L=300	1.8	N69251097
			6	CMP-CVB2050/60-LS, L=240	1.5	N69251098
			6	CMP-CVB2050/60-LS, L=140	0.8	N69251099
			1	CMP-CVB2050/60-LS, L=939	5.5	N69251100
			1	CMP-CVB2050/60-LS, L=939	5.5	N69251101
			1	CMP-CVB2050/60-LS, L=939	5.5	N69251102
			1	CMP-CVB2050/60-LS, L=939	5.5	N69251103
			1	CMP-CVB2050/60-LS, L=939	3.1	N69251104
			1	CMP-CVB2050/60-LS, L=939	3.1	N69251105
CVB30X	305LS	4"x4" (102x102)	32	CMP-CVB30X-IMPERIAL-305LS	1.6	MM0376015
			16	CMP-CVB303-IMPERIAL-305LS	1.5	MM0376092
			2	CMP-CVB30X-IMPERIAL-305LS	3.2	MM0376666
			2	CMP-CVB30X-IMPERIAL-305LS	3.2	MM0376769
			2	CMP-CVB30X-IMPERIAL-305LS	4.8	MM0376777
			2	CMP-CVB30X-IMPERIAL-305LS	4.8	MM0376779
CVB30X	Tension	4"x4" (102x102)	32	CMP-CVB2050/60-TENSION, L=320	1.7	N69251130
			16	CMP-CVB30X-IMPERIAL-SIDE_TENSION	1.1	MM0379079
			2	CMP-CVB30X-IMPERIAL-SIDE_TENSION	5.2	MM0378961
			2	CMP-CVB30X-IMPERIAL-SIDE_TENSION	5.2	MM0378907
			2	CMP-CVB30X-IMPERIAL-SIDE_TENSION	3.6	MM0378804
CVB2060	Tension	100x100	2	CMP-CVB2050/60-TENSION, L=899	3.5	N69251128
			2	CMP-CVB2050/60-TENSION, L=899	3.5	N69251129
			32	CMP-CVB2050/60-TENSION, L=320	1.7	N69251130
			16	CMP-CVB2050/60-TENSION, L=259	1.4	N69251131
			2	CMP-CVB2050/60-TENSION, L=899	6.6	N69251132
CVB2060	Tension Reinforced	120x120	2	CMP-CVB2050/60-TENSION, L=899	6.6	N69251133
			16	CMP-CVB2050/60-TENSION, L=320	1.7	N69251130
			2	CMP-CVB2050/60-TENSION, L=259	1.4	N69251131
			2	CMP-CVB2050/60-TENSION, L=899	6.6	N69251132
			2	CMP-CVB2050/60-TENSION, L=899	6.6	N69251133
CVB2060	Tension Reinforced	120x120	16	Cross member PU wear liner, L=274	1.8	425000.1556
			32	Cross member PU wear liner, L=308	2	425000.1555
			1	Cross member PU wear liner, L=906	9.9	425000.1557
			1	Cross member PU wear liner, L=906	7.5	425000.1558
			1	Cross member PU wear liner, L=906	9.9	425000.1559
			1	Cross member PU wear liner, L=906	7.5	425000.1560
CVB40X	305LS	6"x6" (152x152)	36	CMP-CVB40X-IMPERIAL-305LS	2.3	MM0382811
			12	CMP-CVB40X-IMPERIAL-305LS	2.1	MM0382824
			2	CMP-CVB40X-IMPERIAL-305LS	9.6	MM0382828
			2	CMP-CVB40X-IMPERIAL-305LS	9.6	MM0382860
			2	CMP-CVB40X-IMPERIAL-305LS	5.1	MM0382891
			2	CMP-CVB40X-IMPERIAL-305LS	5.1	MM0382961

Table continues on next page →

General screening media accessories

Screen model	Deck frame	Dimension	Quantity (Per kit)	Description	Weight (kg/each)	Part No.
CVB40X	Tension	6"x6" (152x152)	24	CMP-CVB2661-TENSION, L=300	2.3	N69251147
			12	CMP-CVB40X-IMPERIAL-SIDE_TENSION	2.2	MM0383451
			12	CMP-CVB40X-IMPERIAL-SIDE_TENSION	2.2	MM0383449
			2	CMP-CVB40X-IMPERIAL-SIDE_TENSION	9.5	MM0383585
			2	CMP-CVB40X-IMPERIAL-SIDE_TENSION	9.5	MM0383609
			2	CMP-CVB40X-IMPERIAL-SIDE_TENSION	4.6	MM0383617
			2	CMP-CVB40X-IMPERIAL-TENSION		MM0383619
CVB2661	300LS	150x150	1	CMP-CVB2661-LS, L=1243	4.2	N69251134
			1	CMP-CVB2661-LS, L=1243	4.2	N69251135
			42	CMP-CVB2661-LS, L=300	2.3	N69251142
			6	CMP-CVB2661-LS, L=229	1.7	N69251143
			6	CMP-CVB2661-LS, L=159	1.1	N69251144
			1	CMP-CVB2661-LS, L=1243	4.2	N69251137
			1	CMP-CVB2661-LS, L=1243	4.2	N69251136
			1	CMP-CVB2661-LS, L=1150	9.1	N69251138
			1	CMP-CVB2661-LS, L=1336	10.7	N69251139
			1	CMP-CVB2661-LS, L=1336	10.7	N69251140
CVB2661	Tension	150x150	1	CMP-CVB2661-LS, L=1150	9.1	N69251141
			2	CMP-CVB2661-TENSION, L=1105	4.9	N69251145
			2	CMP-CVB2661-TENSION, L=1105	4.9	N69251146
			24	CMP-CVB2661-TENSION, L=300	2.3	N69251147
			12	CMP-CVB2661-TENSION, L=219	1.7	N69251148
			12	CMP-CVB2661-TENSION, L=286	2.2	N69251149
			2	CMP-CVB2661-TENSION, L=1105	10.5	N69251150
2	CMP-CVB2661-TENSION, L=1105	10.5	N69251151			

Table continues on next page →



General screening media accessories

For Metso TS screens protection

Screen model	Deck frame	Dimension	Quantity (Per kit)	Description	Weight (kg/each)	Part No.
TS2.X	300LS	100x100	1	CMP-TS2.X-LS, L=704	5.3	N69251051
			1	CMP-TS2.X-LS, L=704	5.3	N69251052
			24	CMP-TS2.X-LS, L=300	1.6	N69251053
			16	CMP-TS2.X-LS, L=255	1.4	N69251054
TS2.X	TENSION	100x100	1	CMP-TS2.X-TENSION, L=689	5.3	N69251067
			1	CMP-TS2.X-TENSION, L=689	5.3	N69251068
			16	CMP-TS2.X-TENSION, L=240	1.4	N69251069
			24	CMP-TS2.X-TENSION, L=300	1.6	N69251070
TS3.X	300LS	120x120	1	CMP-TS3.X-LS, L=844	7.4	N69251055
			1	CMP-TS3.X-LS, L=844	7.4	N69251056
			32	CMP-CVB2050/60-LS, L=300	1.8	N69251097
			16	CMP-TS3.X-LS, L=246	1.5	N69251058
TS3.X	TENSION	120x120	1	CMP-TS3.X-TENSION, L=840	7.4	N69251071
			1	CMP-TS3.X-TENSION, L=840	7.4	N69251072
			16	CMP-TS3.X-TENSION, L=242	1.8	N69251073
			32	CMP-TS3.X-TENSION, L=300	1.5	N69251074
TS4.X	300LS	160x160	1	CMP-TS4.X-LS, L=1149	13.4	N69251061
			1	CMP-TS4.X-LS, L=1149	13.4	N69251062
			48	CMP-TS4-5.X-LS, L=300	2.3	N69251042
			16	CMP-TS4-5.X-LS, L=251	2	N69251064
TS4.X	TENSION	160x160	1	CMP-TS4-5.X-TENSION, L=1146	13.7	N69251075
			1	CMP-TS4-5.X-TENSION, L=1146	13.7	N69251076
			16	CMP-TS4-5.X-LS, L=247	2.1	N69251077
			32	CMP-TS4-5.X-LS, L=300	2.5	N69251078
TS5.X	300LS	160x160	1	CMP-TS4.X-LS, L=1149	13.4	N69251061
			1	CMP-TS4.X-LS, L=1149	13.4	N69251062
			66	CMP-TS4-5.X-LS, L=300	2.3	N69251042
			22	CMP-TS4-5.X-LS, L=251	2	N69251064
TS5.X	TENSION	160x160	1	CMP-TS4-5.X-TENSION, L=1146	13.7	N69251075
			1	CMP-TS4-5.X-TENSION, L=1146	13.7	N69251076
			22	CMP-TS4-5.X-LS, L=247	2.1	N69251077
			44	CMP-TS4-5.X-LS, L=300	2.5	N69251078
TS6.X	300LS	220x220	88	CMP-TS6.X-LS, L=300	3.3	N69251065
			22	CMP-TS6.X-LS, L=251	2.9	N69251066
			2	CMP-TS6.X-LS, L=1449 - 1	14	N69251059
			2	CMP-TS6.X-LS, L=1449 - 2	14	N69251060
TS6.X	TENSION	220x220	1	CMP-TS6.X-TENSION, L=1446	24.5	N69251080
			1	CMP-TS6.X-TENSION, L=1446	24.5	N69251081
			22	CMP-TS6.X-TENSION, L=240	2.7	N69251082
			66	CMP-TS6.X-TENSION, L=300	3.3	N69251083
			22	CMP-TS6.X-TENSION, L=308	3.1	N69251084

Table continues on next page 

General screening media accessories

Screen model	Deck frame	Dimension	Quantity (Per kit)	Description	Weight (kg/each)	Part No.
TS4.X	300LS	6"x6" (152x152)	1	CMP-TS4.X-LS, L=1149	13.4	N69251061
			1	CMP-TS4.X-LS, L=1149	13.4	N69251062
			48	SM-ACC-CMP-CVB2661-LS-300	2.3	N69251142
			16	SM-ACC-CMP-TS4-5.X-LS-251	2	N69251157
TS5.X	300LS	6"x6" (152x152)	1	CMP-TS4.X-LS, L=1149	13.4	N69251061
			1	CMP-TS4.X-LS, L=1149	13.4	N69251062
			66	SM-ACC-CMP-CVB2661-LS-300	2.3	N69251142
			22	SM-ACC-CMP-TS4-5.X-LS-251	2	N69251157



General screening media accessories

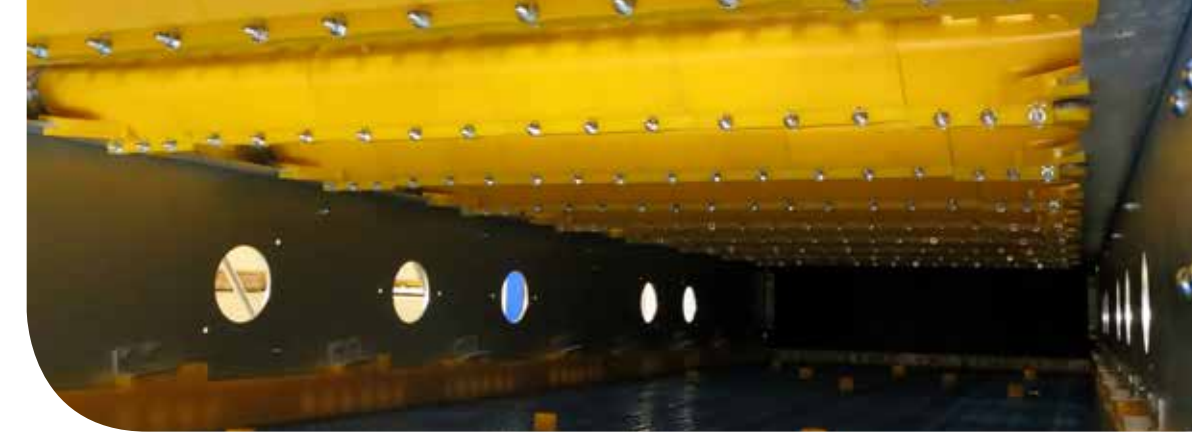

For Metso ES/CVB 20X and 30X screens

Part No.	Description	Weight (kg/ea)	ES/CVB 10X		ES/CVB 20X		ES/CVB 30X	
			MM0413864 TENSION (qty)	MM0413178 305LS (qty)	MM0403032 TENSION (qty)	MM0403066 305LS (qty)	MM0403790 TENSION (qty)	MM0403791 305LS (qty)
MM0391602	SM-ACC CMP-ES40X-TENSION	8.6						
MM0391566	SM-ACC CMP-ES40X-TENSION	8.6						
MM0391537	SM-ACC CMP-ES40X-TENSION	3.4						
MM0391536	SM-ACC CMP-ES40X-TENSION	3.4						
MM0391458	SM-ACC CMP-ES40X-TENSION	2.6						
MM0385365	SM-ACC CMP-ES40X-TENSION	2.6						
MM0385364	SM-ACC CMP-ES40X-TENSION	2.7						
MM0384544	SM-ACC CMP-ES40X-305LS	3.2						
MM0384534	SM-ACC CMP-ES40X-305LS	3.2						
MM0384459	SM-ACC CMP-ES40X-305LS	9						
MM0384461	SM-ACC CMP-ES40X-305LS	2.6						
MM0384357	SM-ACC CMP-ES30X-305LS	6.2				2		2
MM0384321	SM-ACC CMP-ES30X-305LS	2.2				6		8
MM0384317	SM-ACC CMP-ES30X-305LS	2.2				6		8
MM0384281	SM-ACC CMP-ES30X-305LS	2.1				24		32
MM0385278	SM-ACC CMP-ES30X-TENSION	6.1			1		1	
MM0385008	SM-ACC CMP-ES30X-TENSION	6.1			1		1	
MM0385293	SM-ACC CMP-ES30X-TENSION	2			6		8	
MM0385287	SM-ACC CMP-ES30X-TENSION	2			6		8	
MM0384871	SM-ACC CMP-ES30X-TENSION	2.4			24		32	
MM0413174	SM-ACC CMP-CVB10X-305LS	1.7		15				
MM0413175	SM-ACC CMP-CVB10X-305LS	2		5				
MM0413176	SM-ACC CMP-CVB10X-305LS	2		5				
MM0413177	SM-ACC CMP-CVB10X-305LS	8.7		1				
MM0413633	SM-ACC CMP-CVB10X-TENSION	1.7	20					
MM0413719	SM-ACC CMP-CVB10X-TENSION	1.5	5					
MM0413751	SM-ACC CMP-CVB10X-TENSION	1.5	5					
MM0413843	SM-ACC CMP-CVB10X-TENSION	8.7	1					
7001530110	SCREW, HEXAGONAL ISO4017-M8X40-8.8-A3A	0.02	90	75	108	108	144	144
704203927080	NUT, HEXAGONAL, TORQUE ISO7040-M8-8-A3A	0.06	90	75	108	108	144	144
704006880000	WASHER, PLAIN DIN125-A8.4-140HV-A3A	0.01	180	150	216	216	288	288
N01530204	SCREW, HEXAGONAL ISO4017-M12X50-8.8-A3A	0.05	6	5	6	6	6	6
704203927120	NUT, HEXAGONAL, TORQUE ISO7040-M12-8-A3A	0.015	6	5	6	6	6	6
N01633013	WASHER, LOCK NL12SP	0.01	12	10	12	12	12	12

For Metso ES/CVB 40X and CVB 50X screens

Part No.	Description	Weight (kg/ea)	ES/CVB 40X		CVB 50X		CVB 60X	
			MM0384870 TENSION (qty)	MM0384566 305LS (qty)	MM0403792 TENSION (qty)	MM0403793 305LS (qty)	MM0422296 TENSION (qty)	MM0415791 305LS (qty)
MM0391602	SM-ACC CMP-ES40X-TENSION	8.6	1		1		1	
MM0391566	SM-ACC CMP-ES40X-TENSION	8.6	1		1		1	
MM0391537	SM-ACC CMP-ES40X-TENSION	3.4	8		10		10	
MM0391536	SM-ACC CMP-ES40X-TENSION	3.4	8		10		10	
MM0391458	SM-ACC CMP-ES40X-TENSION	2.6	8		10		10	
MM0385365	SM-ACC CMP-ES40X-TENSION	2.6	8		10		10	
MM0385364	SM-ACC CMP-ES40X-TENSION	2.7	32		40		40	
MM0384544	SM-ACC CMP-ES40X-305LS	3.2		8		10		10
MM0384534	SM-ACC CMP-ES40X-305LS	3.2		8		10		10
MM0384459	SM-ACC CMP-ES40X-305LS	9		2		2		2
MM0384461	SM-ACC CMP-ES40X-305LS	2.6		48		60		60
MM0384357	SM-ACC CMP-ES30X-305LS	6.2						
MM0384321	SM-ACC CMP-ES30X-305LS	2.2						
MM0384317	SM-ACC CMP-ES30X-305LS	2.2						
MM0384281	SM-ACC CMP-ES30X-305LS	2.1						
MM0385278	SM-ACC CMP-ES30X-TENSION	6.1						
MM0385008	SM-ACC CMP-ES30X-TENSION	6.1						
MM0385293	SM-ACC CMP-ES30X-TENSION	2						
MM0385287	SM-ACC CMP-ES30X-TENSION	2						
MM0384871	SM-ACC CMP-ES30X-TENSION	2.4						
MM0415744	SM-ACC CMP-CVB60X-305LS	11.5						2
MM0415697	SM-ACC CMP-CVB60X-305LS	3.9						10
MM0415682	SM-ACC CMP-CVB60X-305LS	3.9						10
MM0415157	SM-ACC CMP-CVB60X-305LS	2.8						80
MM0422183	SM-ACC CMP-CVB60X-TENSION@	11.6						1
MM0422129	SM-ACC CMP-CVB60X-TENSION	11.6						1
MM0421952	SM-ACC CMP-CVB60X-TENSION	2.8						10
MM0421948	SM-ACC CMP-CVB60X-TENSION	2.8						10
MM0417117	SM-ACC CMP-CVB60X-TENSION	3.9						10
MM0417116	SM-ACC CMP-CVB60X-TENSION	3.9						10
MM0417033	SM-ACC CMP-CVB60X-TENSION	2.9						60
7001530110	SCREW, HEXAGONAL ISO4017-M8X40-8.8-A3A	0.02	192	192	240	240	240	240
704203927080	NUT, HEXAGONAL, TORQUE ISO7040-M8-8-A3A	0.06	192	192	240	240	240	240
704006880000	WASHER, PLAIN DIN125-A8.4-140HV-A3A	0.01	384	384	480	480	480	480
N01530204	SCREW, HEXAGONAL ISO4017-M12X50-8.8-A3A	0.05	8	8	8	8	8	8
704203927120	NUT, HEXAGONAL, TORQUE ISO7040-M12-8-A3A	0.015	8	8	8	8	8	8
N01633013	WASHER, LOCK NL12SP	0.01	16	16	16	16	16	16

General screening media accessories

Screen feedbox and discharge spout lining

The screen feed box lining solution includes a variety of options suitable for dry or wet screening applications. The solution is based on either Trellex PP wear rubber system or Trellex Poly-Cer system or a combination of both.

The solution also offers a unique overlap sealing system to avoid material build-up between lining and screen. Available as a standard solution for Metso screens and tailor-made solution for other screen brands.

Replaceable rubber liners

- Screen feedbox
- Discharge lips

Discharge lips also available in polyurethane and Poly-Cer.

For further information please see Metso Lining and Sheeting handbook.

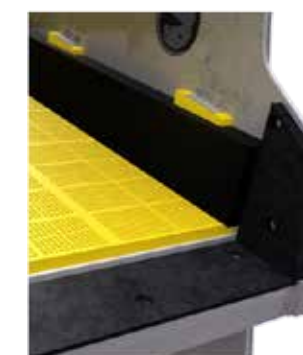

General screening media accessories

Standard Trellex rubber

Designed for Metso mining screens MF/LH/RF

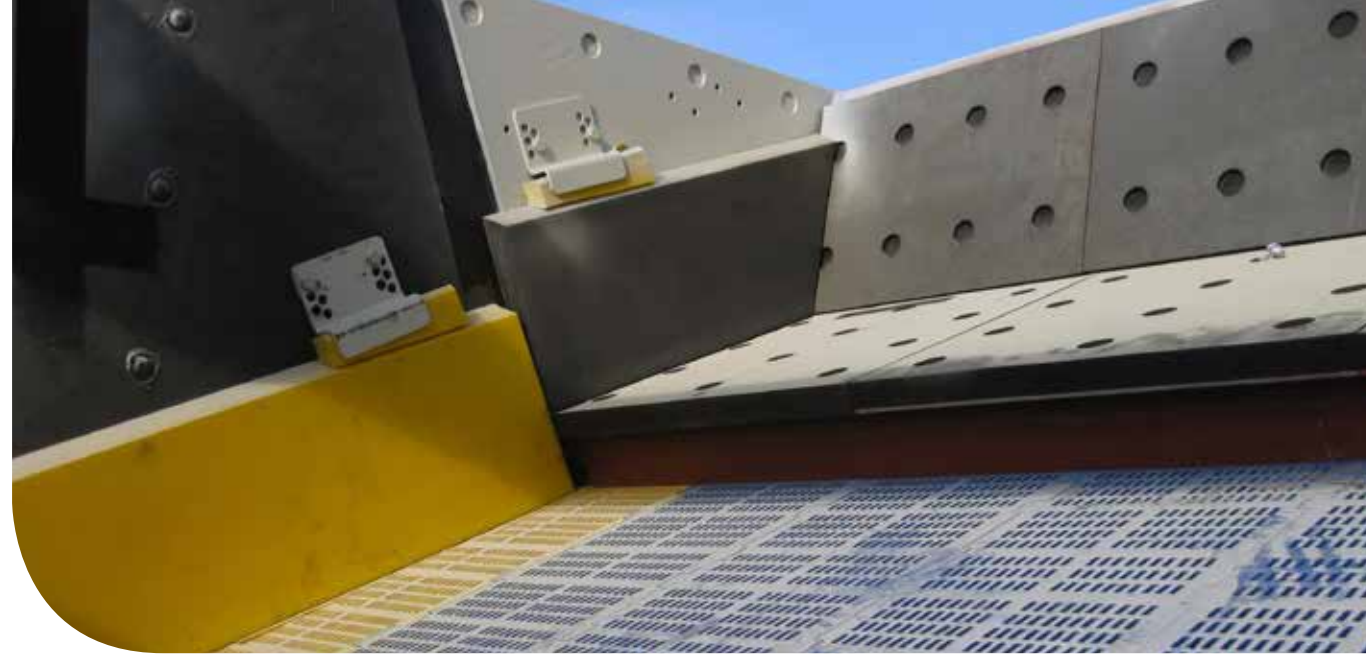
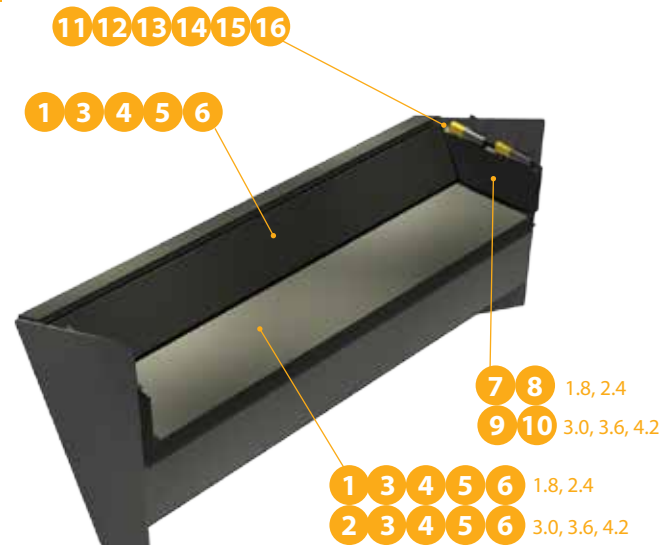

Feed Box Lining - Metso MF, LH and RF screens

Item	Part No.	Part No. (OEM)*	Description	Weight (kg/ea)	Screen width (m), Feed box length (mm) Quantities/screen machine				
					1.8 L=400	2.4 L=400	3.0 L=600	3.6 L=600	4.2 L=600
New Feed Box Lining Arrangement									
1	6620755	MM0602289	TRELLEX PP 40/5 400-618 E-T20/T60	18.50	6	8	5	6	7
2	6620783	MM0601501	TRELLEX PP 40/5 600-620 E-T20/T60	27.50			5	6	7
Old Feed Box Lining Arrangement									
1	6620755	MM0602289	TRELLEX PP 40/5 400-618 E-T20/T60	18.50	4	6	4	5	6
1	6620784	MM0602808	TRELLEX PP 40/5 400-595 E-T20/T60	18.00	2	2	1	1	1
2	6620783	MM0601501	TRELLEX PP 40/5 600-620 E-T20/T60	27.50			4	5	6
2	6620769	MM0602810	TRELLEX PP 40/5 590-600 E-T20/T60	26.70			1	1	1
Attachment Details									
3	315150	MM0250535	TRELLEX M16 NYLOC	0.04	36	48	60	72	84
4	292714	7001530310	BOLT, HEXAGONAL ISO4014-M16X40-8.8-A3F	0.09	36	48	60	72	84
5	T251600	N01633017	SM-ACC BRICKA NORDLOCK 16 D=17 D=25.4	0.01	36	48	60	72	84
6	ML-248025	ML-248025	ML-RUBBERPLUG 60/50-35	0.08	36	48	60	72	84
7	MM0364176	MM0614467	TRELLEX PP 50/5 300-598 A T60 RH	12.80	1	1			
8	MM0364178	MM0614471	TRELLEX PP 50/5 300-598 A T60 LH	12.80	1	1			
9	MM0358304	MM0614448	TRELLEX PP 50/5 300-770/587 R	18.30			1	1	1
10	MM0358306	MM0614443	TRELLEX PP 50/5 300-770/587 L	18.30			1	1	1
11	6681339	MM0609221	LS ACC-WEDGE-40-48-32-220-75/90-L	0.50	2	2	2	2	2
12	6681340	MM0608964	LS ACC-WEDGE-40-48-32-220-75/90-R	0.50	2	2	2	2	2
13	MM0364175	MM0610144	SM-ACC STEEL CLAMP FOR PU WEDGE - LH	1.20	2	2	2	2	2
14	MM0364174	MM0610140	SM-ACC STEEL CLAMP FOR PU WEDGE - RH	1.20	2	2	2	2	2
15	7001530190	7001530190	SCREW, HEXAGONAL ISO4017-M12X20-8.8-A3A	0.03	8	8	8	8	8
16	401810	704006970000	WASHER, PLAIN BRB 2x13/24	0.01	8	8	8	8	8

Back Plate Lining - Metso MF, LH and RF screens

Part No.	Part No. (OEM)*	Description	Weight (kg/ea)	Screen width (m), Feed box length (mm) Quantities/screen machine				
				1.8 L=400	2.4 L=400	3.0 L=600	3.6 L=600	4.2 L=600
New Back Plate Lining Arrangement								
6620755	MM0602289	TRELLEX PP 40/5 400-618 E-T20/T60	18.50	3	4	5	6	7
Old Back Plate Lining Arrangement								
6620784	MM0602808	TRELLEX PP 40/5 400-595 E-T20/T60	18.00	1	1	1	1	1
6620755	MM0602289	TRELLEX PP 40/5 400-618 E-T20/T60	18.50	2	3	4	5	6
Attachment Details								
315150	MM0250535	TRELLEX M16 NYLOC	0.04	18	24	30	36	42
292714	7001530310	BOLT, HEXAGONAL ISO4014-M16X40-8.8-A3F	0.09	18	24	30	36	42
T251600	N01633017	SM-ACC BRICKA NORDLOCK 16 D=17 D=25.4	0.01	18	24	30	36	42
ML-248025	ML-248025	ML-RUBBERPLUG 60/50-35	0.08	18	24	30	36	42

* Part No. OEM relates to originally issued parts included in spare parts lists

General screening media accessories

Standard Trellex Poly-Cer

Designed for Metso mining screens MF/LH/RF



Item	Part No.	Description	Screen 1.8 (qty)	Screen 2.4 (qty)	Weight (kg/ea)
1	MM0363260	Trellex Poly-Cer 64/5 618-450	3	4	49.3
2	MM0363288	Trellex Poly-Cer 64/5 618-400	3	4	46.5
3	2934210	Trellex T-bolt TF 35/55 M16x70/55	24	32	0.22
4	MM0393220	Washer 3x17/50	24	32	0.04
5	315150	Nut nyloc M16	24	32	0.035
6	MM0363350	Trellex PP 50/5 300-585 LH	1	1	12.4
7	MM0363351	Trellex PP 50/5 300-585 RH	1	1	12.4
8	6681339	Wedge PU LH	2	2	0.5
9	6681340	Wedge PU RH	2	2	0.5
10	MM0363322	Trellex PP 15/3 620-200	3	4	4
11	MM0364175	Steel clamp for PU-wedge LH	2	2	1.15
12	MM0364174	Steel clamp for PU-wedge RH	2	2	1.15
13	401810	Washer 2x13/24	20	24	0.005
14	7001530190	Bolt M12x20	8	8	0.03
15	2028000	Bolt M12x40	6	8	0.044
16	294215	Nut nyloc M12	6	8	0.018
Screen 1.8 MM0363951 One SET item 1-16			338 kg		
Screen 2.4 MM0363954 One SET item 1-16			440 kg		

Item	Part No.	Description	Screen 3.0 (qty)	Screen 3.6 (qty)	Screen 4.2 (qty)	Weight (kg/ea)
1	MM0363307	Trellex Poly-Cer 64/5 623-380	5	6	7	42.2
2	MM0363309	Trellex Poly-Cer 64/5 623-600	5	6	7	68
3	2934210	Trellex T-bolt TF 35/55 M16x70/55	40	48	56	0.22
4	MM0393220	Washer 3x17/50	40	48	56	0.04
5	315150	Nut nyloc M16	40	48	56	0.035
6	MM0363304	Trellex PP 50/5 300-757 LH	1	1	1	17.2
7	MM0363305	Trellex PP 50/5 300-757 RH	1	1	1	17.2
8	6681339	Wedge PU LH	2	2	2	0.5
9	6681340	Wedge PU RH	2	2	2	0.5
10	MM0363322	Trellex PP 15/3 620-200	5	6	7	4
11	MM0364175	Steel clamp for PU-wedge LH	2	2	2	1.15
12	MM0364174	Steel clamp for PU-wedge RH	2	2	2	1.15
13	401810	Washer 2x13/24	28	32	36	0.005
14	7001530190	Bolt M12x20	8	8	8	0.03
15	2028000	Bolt M12x40	10	12	14	0.044
16	294215	Nut nyloc M12	10	12	14	0.018
Screen 3.0 MM0363955 One SET item 1-16			624 Kg			
Screen 3.6 MM0363956 One SET item 1-16			740 Kg			
Screen 4.2 MM0363957 One SET item 1-16			857 Kg			

Fixing alternative for wet conditions

Part No.	Description
MM0369039	Trellex T-bolt M16 package for wet-screening including T-bolt, rubber sealing, cup washer and nut M16 nylock

General screening media accessories

Standard Trellex rubber

Designed for Metso construction screens ES and CVB

Feed box lining

Item	Part No.	Description	Weight (kg/ea)	CVB & ES (Quantities/screen)				
				10X	20X	30X	40X	50X
1	MM0412310	TRELLEX PP 30/5 305-200 T16/T60	2.60	5				
2	MM0412305	TRELLEX PP 30/5 305-500 T16/T60	8.90	5				
3	MM0412395	TRELLEX PP 30/5 222-575 A-T16/T60	6.30	1				
4	MM0412373	TRELLEX PP 30/5 222-575 A-T16/T60	6.30	1				
1	MM0398574	TRELLEX LSS PP 25/3 612-626 A-T16/T60	16.90		3	3	4	4
2	MM0398606	TRELLEX LSS PP 25/3 315-612 A-T16/T60	8.00		3	3	4	4
3	MM0398615	TRELLEX LSS PP 25/3 338-737 A-T16/T60	9.10		1	1	1	1
4	MM0398609	TRELLEX LSS PP 25/3 338-737 A-T16/T60	9.10		1	1	1	1

Cardan shaft protection

Item	Part No.	Description	Weight (kg/ea)	Used in the following models
1	MM0413169	TRELLEX LSS PP 20/4 911-424-T16-T60	18.50	CVB10X
2	MM0414926	TRELLEX LSS PP 20/4 891-424-T16-T60	18.10	CVB104
2	MM0407356	TRELLEX LSS PP 20/4 1090-424-T16-T60	22.20	CVB304
3	MM0400953	TRELLEX LSS PP 20/4 1196-424-T16-T60	24.40	ES202. ES203. ES302. ES303. CVB303
5	MM0407350	TRELLEX LSS PP 20/4 1216-424-T16-T60	24.80	CVB202, CVB203, CVB204, CVB302
4	MM0400951	TRELLEX LSS PP 20/4 1700-424-T16-T60	34.90	CVB403. CVB502. ES402. ES403
5	MM0400954	TRELLEX LSS PP 20/4 1806-424-T16-T60	37.10	CVB402. CVB503
8	MM0413192	TRELLEX LSS PP 20/4 2310-424-T16-T60	47.60	CVB603
9	MM0413213	TRELLEX LSS PP 20/4 2416-424-T16-T60	49.80	

Discharge lip area - LS & Tension Deck Frames

Item	Part No.	Description	Weight (kg/ea)	CVB & ES (Quantities/screen)					
				10X	20X	30X	40X	50X	60X
1	MM0400109	TRELLEX LSS PP 25/3-290-195-T16/T60	2.30	2	2	2	2	2	2
2	MM0400110	TRELLEX LSS PP 25/3-612-200-T16/T60	5.10		3	3	4	4	5
3	MM0400571	TRELLEX LSS PP 10/5-170-612-T16/T60	2.60		3	3	4	4	5
2	MM0413296	TRELLEX LSS PP 25/3-1530-200-T16/T60	17.80	1					
3	MM0413334	TRELLEX LSS PP 10/5-170-1530-T16/T60	13.60	1					

Discharge lip area - PCO Deck Frames

Item	Part No.	Description	Weight (kg/ea)	CVB & ES (Quantities/screen)					
				10X	20X	30X	40X	50X	60X
1	MM0410739	TRELLEX PP 45/5 105-612 T16/T60	5.00		3	3	4	4	5
3	MM0415970	TRELLEX PP 45/5 100-1534 T16/T60	12.40	1					

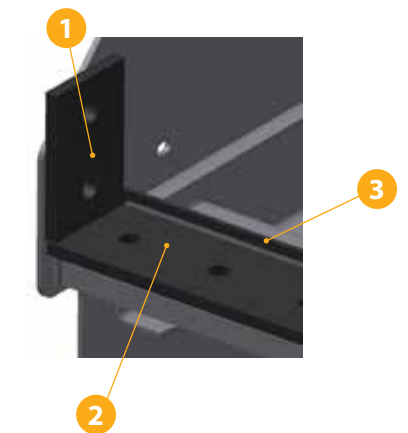
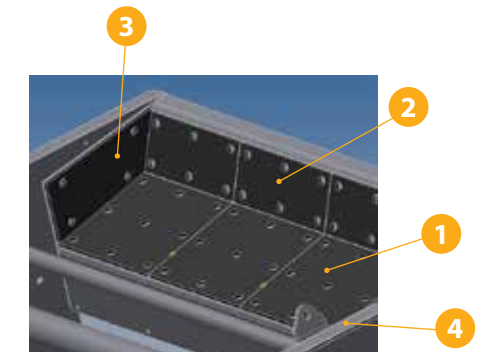

General screening media accessories

Trellex Dust control

Take the dust and noise out of materials handling

Dust can cause big problems. Modern aggregate operations and mining processing facilities generate large amounts of dust. Not only is dust a health hazard, it also accelerates wear and tear on equipment and complicates maintenance work. Dust increases the risk of corrosion and the cost of maintenance.

With simple, standardized components, we customize the dust sealing for your equipment.

The Trellex Dust Control system also reduces noise – in many cases up to 10-12 decibels – the effect of cutting noise by half.

- Wear-resistant
- Corrosion-resistant
- Economical

Please contact your Metso representative for further details.



General screening media accessories

Trellex Dust control

Rubber components

Part No.	Description	Unit	Weight (kg)	Dimension (mm)
75119	SM-ACC DUST-GC-14-55H [Grip corner 14-55H]	EA	0.3	150 X 150
75101	SM-ACC DUST-GC-14-55V [Grip corner 14-55V]	EA	0.3	150 X 150
75085	DUST SEALING RU-GS-14-1350 [Grip strip no 14]	EA	1.1	L=1350
75093-1	DUST SEALING RU-CLOTH *	M2	2.3	1350 X 20000 X 2
101543-1	SM-ACC DUST-RU-CLOTH-ANTIFLAME **	M2	2.3	1350 X 20000 X 2
2332930	SM-ACC DUST-RU-CLOTH-HIGH TEMP ***	M2	2.3	1350 X 20000 X 2

* Standard dust sealing cloth (-40 to +50°)

** Anti-flame dust sealing cloth, 1518 (-30 to +70°)

*** High temp dust sealing cloth, 4896 (-30 to +130°)

STM 40 Steel profiles

Part No.	Description	Unit	Weight (kg)	Dimension (mm)	Connect to profile
2246970	SM-ACC DUST-STM-3A-40-3600	EA	5.0	L=3600	
2247540	SM-ACC STM 2-40 CORNER	EA	0.2	110 X 110	STM 3A
371039	SM-ACC STM 4-40 CORNER	EA	0.3	110 X 110	STM 3A, 10A
2332910	SM-ACC STM 4B-40 CORNER	EA	0.2	110 X 110	STM 3B-40
2332690	SM-ACC STM 17-40 CORNER	EA	0.2	110 X 110	STM 3A
372961	SM-ACC STM 19-40 CORNER	EA	0.3	110 X 110	STM 3A
372979	SM-ACC STM 20-40 CORNER	EA	0.3	130 X 130	STM 3A, 10A
2332920	SM-ACC STM 22B-40 CORNER	EA	0.3	110 X 110	STM 3B
2247000	SM-ACC DUST-STM-3B-40-3600	EA	6.0	L=3600	
2128240	SM-ACC DUST-STM-3D-40-3600	EA	6.0	L=3600	

STM 60 Steel profiles

Part No.	Description	Unit	Weight (kg)	Dimension (mm)	Connect to profile
2246900	SM-ACC DUST-STM1-60-3600	EA	4.0	L=3600	
2246930	SM-ACC DUST-STM-1A-60-3600	EA	6.0	L=3600	
257659	SM-ACC STM 2 -60 CORNER	EA	0.3	110 X 110	STM 1, 1A
2247520	SM-ACC STM 4-60 CORNER	EA	0.4	110 X 110	STM 1, 1A
2247020	SM-ACC STM 4B-60 CORNER	EA	0.4	110 X 110	STM 1
372938	SM-ACC STM 17-60 CORNER	EA	0.3	110 X 110	STM 1, 1A
2247530	SM-ACC STM 19-60 CORNER	EA	0.3	110 X 110	STM 1, 1A

General screening media accessories

Other STM Steel profiles

Part No.	Description	Unit	Weight (kg)	Dimension (mm)
2247120	SM-ACC DUST-STM-1-95-3600	EA	7.0	L=3600
2332790	SM-ACC DUST-STM-28A-3000	EA	12.5	60x40x3, L=3000
2333520	SM-ACC DUST-STM-28B-3000	EA	5.4	80x40x3, L=3000
2333510	SM-ACC DUST-STM-28D-1350	EA	1.5	25x25x2, L=1350
2128300	SM-ACC DUST-STM-27D TOP FRAME OUTER	M	Order based	w=200, L=<1800 *
2128310	SM-ACC DUST-STM-27D TOP FRAME OUTER	M	Order based	w=200, L=>1800 *
2247490	SM-ACC DUST-STM-27D TOP FRAME INNER	M	Order based	w=200, L=<1800 *
2247500	SM-ACC DUST-STM-27D TOP FRAME INNER	M	Order based	w=200, L=>1800 *
2247070	SM-ACC DUST-STM-10A-40-3600	EA	18.0	L=3600
371054	SM-ACC DUST-STM-9 PROFILE	EA	7.0	L=1350
2247310	SM-ACC DUST-STM-8A PROFILE W/ HANDRAIL	EA	3.1	L=1350



General screening media accessories

Trellex Spray nozzles

Trellex Spray nozzles work equally effectively with high or low water pressure with an operating range from 40 to 300 kPa (6 to 40 psi). The nozzles give a sharp, defined, fan-shaped water jet providing efficient cleaning. Trellex Spray nozzles are ideal for washing, dust control and deslurrying applications. Trellex Spray nozzles made from polyurethane ensure efficient cleaning.

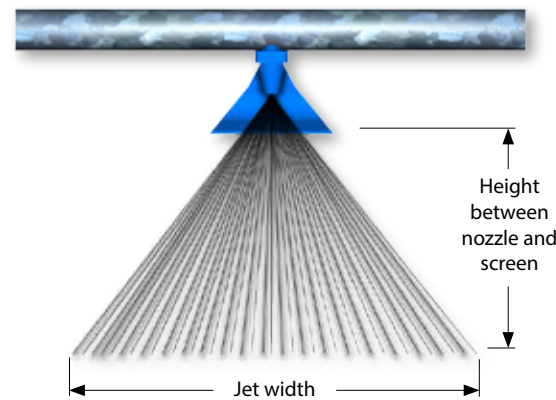

Illustration 1. Depending on height between nozzle and screen, jet width will differ (see table on next page)

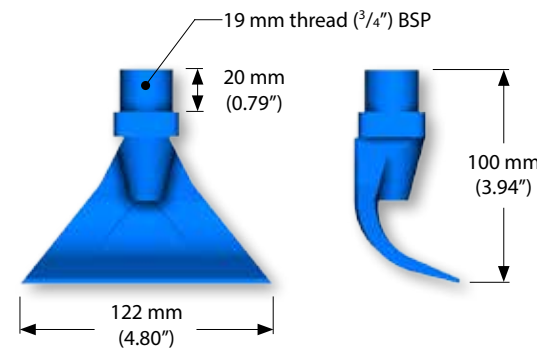

Illustration 2. Basic dimensions of Trellex Spray Nozzle

Key benefits include:

- For pressures from 40 to 300 kPa (6 to 40 psi)
- Provides an even, sharp, defined water jet
- Wear-resistant
- Corrosion-resistant
- Economical

Part No.	Nozzle-opening Ø (mm)	Thread BSP (mm)	(in)	Colour
1819680	5	19	3/4"	Green
1819690	7	19	3/4"	Blue
1819700	9	19	3/4"	Yellow
1819710	11	19	3/4"	Red



Height between nozzle and screen, mm [inch.]	Trellex Spray nozzle, Jet width, mm [inch.]							
	Nozzle size, mm [inch.]				Nozzle size, mm [inch.]			
	5 [3/16"]		7 [1/4"]		9 [3/8"]		11 [9/16"]	
150	250	150	250	150	250	150	250	
(22)	(36)	(22)	(36)	(22)	(36)	(22)	(36)	
200	600	600	800	600	800	600	800	
[8]	[24]	[24]	[31]	[24]	[31]	[24]	[31]	
300	750	850	1000	800	1000	800	1000	
[12]	[30]	[33]	[39]	[31]	[39]	[31]	[39]	
400	900	1000	1200	1000	1200	1000	1200	
[16]	[36]	[39]	[47]	[39]	[47]	[39]	[47]	

Water flow rate in relation to pressure

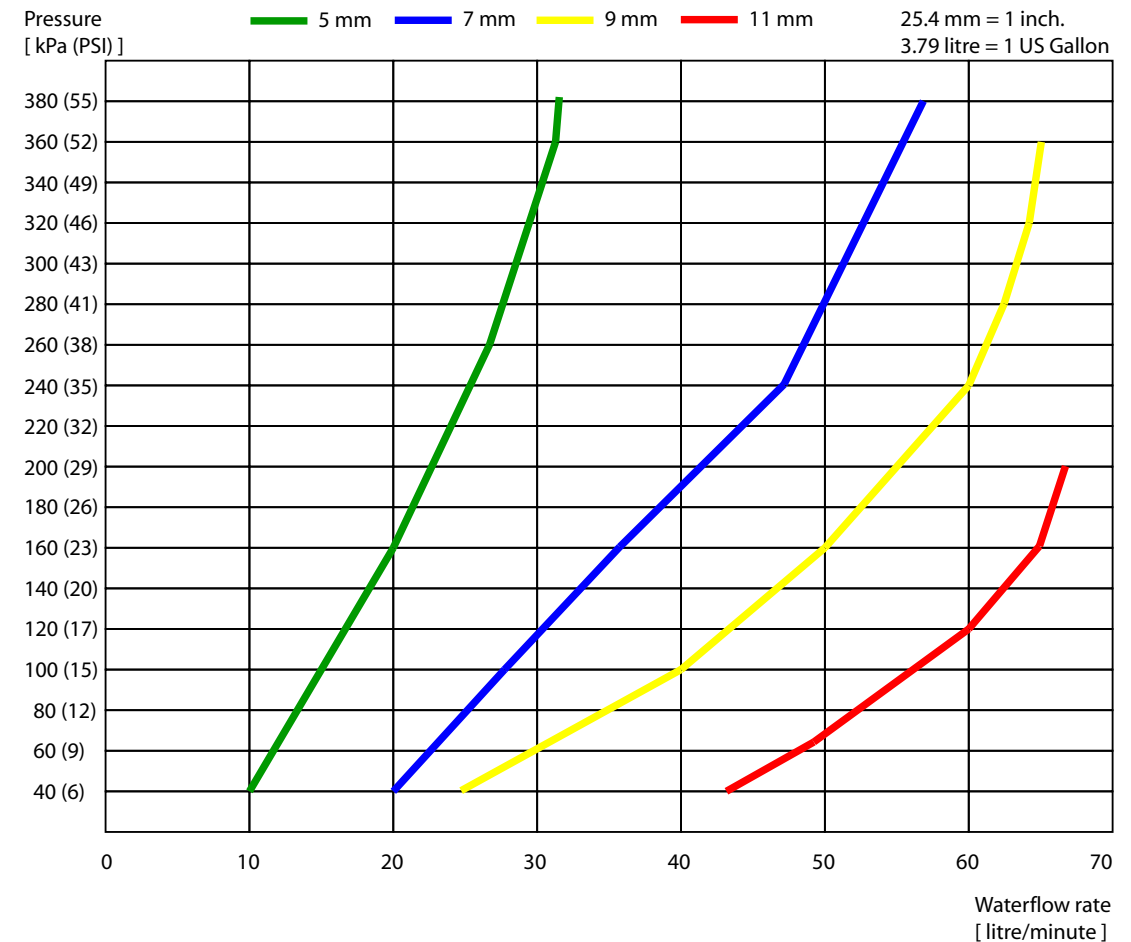

SUPPORTING MATERIAL

Selection guide

Our selection guide for screening media is divided into three sections:

- Modular system
- Tension system
- Panel system

The selection guides allows you to compare and select products, bringing maximum value to your application.

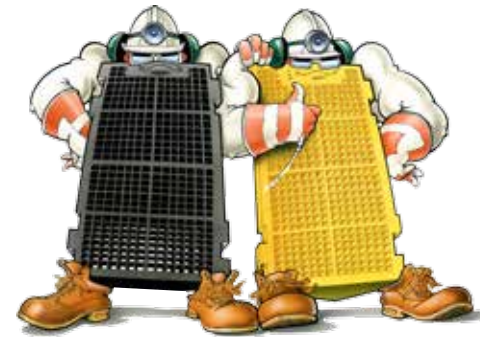

Selection guide

Modular system

	300/305LS Rubber	300/305LS Polyurethane	300/305LS HiPerClean	300/305LS HiPerFlow	305LS HiPerDrain	300/305LS HiPerLife
Max feed size range (mm)	20 - 200	20 - 75	2 - 50	2 - 40	2 - 30	20-250
Separation range (mm)	2 - 75	2 - 40	2 - 20	2 - 20	0.3 - 0.8	10-60
Max Drop Height (mm)	500	350	350	300	300	650
Applications	Allround wet/dry	Allround wet/dry	Construction - final screening Fines removal / control screening High humidity feed - small separations	Construction - final screening For high throughput requirements	Aggregate dewatering Dense media circuits	Secondary screens Mill discharge screens Screening abrasive material
Module Design	300x500 300x610 305x610	300x500 300x610 305x610	300x500 300x610 305x610	300x500 300x610 305x610	305x610	300x500 300x610 305x610
Aperture design	Molded or punched	Molded	Molded	Molded	Molded	Molded
Material	Wear-resistant rubber	Dual-hardness polyurethane	Flexible wear-resistant rubber	Dual-hardness polyurethane	Thermoplastic polyurethane	Extra wear-resistant rubber
Material hardness (Sh-A)	60	70, 80 or 90	40	70, 80 or 90	90	60
Total media build heights (mm)	30, 40 or 60	30	30 or 40	30	40	40 or 60
Attachment	snap-on	snap-on	snap-on	snap-on	snap-on	snap-on

Tension system

	Trellex TFX	Trellex TCO	Trellex TCO
Max feed size (mm)	20 - 40	20 - 180	20 - 75
Separation range (mm)	2 - 20	5 - 120	2 - 40
Max Drop Height (mm)	350	600	350
Applications	Construction - final screening Fines removal / control screening High humidity feed - small separations	Allround wet/dry	Allround wet/dry
Module Design	According to order Max size 3000x1520	According to order Max size 3000x1520	According to order Max size 2500x1520
Aperture design	Molded, punched	Punched	Molded
Material	Flexible wear-resistant rubber	Wear-resistant rubber	Polyurethane
Material hardness (Sh-A)	40	60	70, 80 or 90
Total media build heights or thickness (mm)	3.5, 5.5 or 8	5, 7, 10, 15, 20, 25, 35, 50	25, 35 or 45
Attachment	Tensioned transversal or longitudinal	Tensioned transversal or longitudinal	Tensioned transversal or longitudinal

Panel system

	Trellex 610MP	Trellex PCO
Max feed size (mm)	600 - 700	600 - 700
Separation range (mm)	30 - 130	30 - 130
Max Drop Height (mm)	800 - 1000	800 - 1000
Applications	Primary screening Secondary screening	Primary screening Secondary screening
Module Design	610x610	According to order Max size 1800x1200
Aperture design	Molded	Molded
Material	Wear-resistant rubber	Wear-resistant rubber
Material hardness (Sh-A)	60	60
Total media build heights or thickness (mm)	55, 70 and 80	37, 45, 55, 70 and 80
Attachment	Clamped with hold-down bars	Bolt-down or clamp down

Selection guide

Different aperture types



FR - Square apertures - The most common type of aperture. Normally resulting in the most accurate separation.



FS - Square apertures in staggered pattern. Same applications as FR but apertures are arranged to prevent "tracking" of fines.



SLS - Rectangular apertures with the flow typically recommended for screening material with high content of fines or if there are signs of pegging.



SL - Rectangular apertures with the flow typically recommended for screening material with high content of fines or if there are signs of pegging.



STS - Rectangular apertures across the flow. Normally recommended for dewatering applications.



ST - Rectangular apertures across the flow in staggered pattern. Can be used as an alternative in dewatering applications.



C - Round apertures have similar applications to FR openings. Traditionally used in applications such as primary screening.



CS - Round apertures in staggered pattern. Same applications as C but arranged to prevent "tracking" of fines.

More info

EX - Extra high effective open are, typically >+20% compared to standard aperture of same size.

HD - Heavy duty version, consisting of thicker membrane or/and higher build height, better reinforcement and thicker ligaments between apertures compared to standard version.

M - Moulded, tapered opening for less pegging risk.

Selection guide

Clarification of the description

Trellex LS PU standard

300LS-500-40-25-75/80-FR36M-E

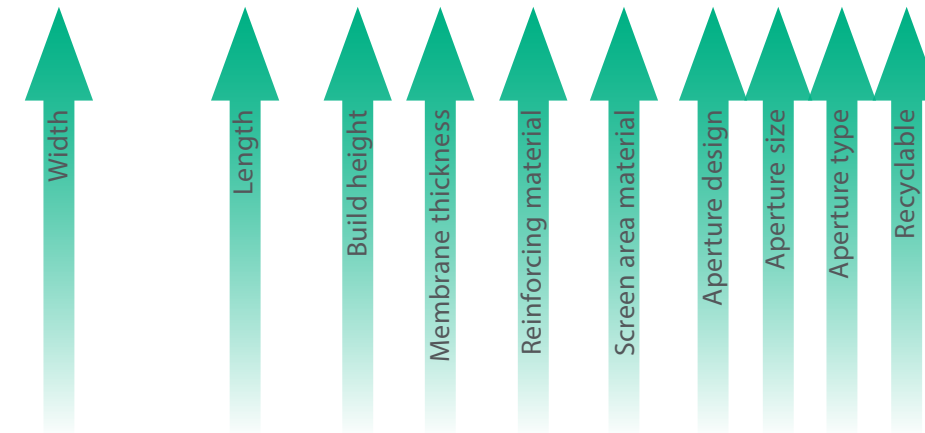

Material quality

75/80 = Dual hardness
75Sh-D bottom, 80Sh-A top

Aperture design

SLS = Slot with flow
STS = Slot against flow
FR = Square opening

Aperture type

M = Molded

Trellex LS RU standard

305LS-610-40-30-SF/T60-SLS20x40M

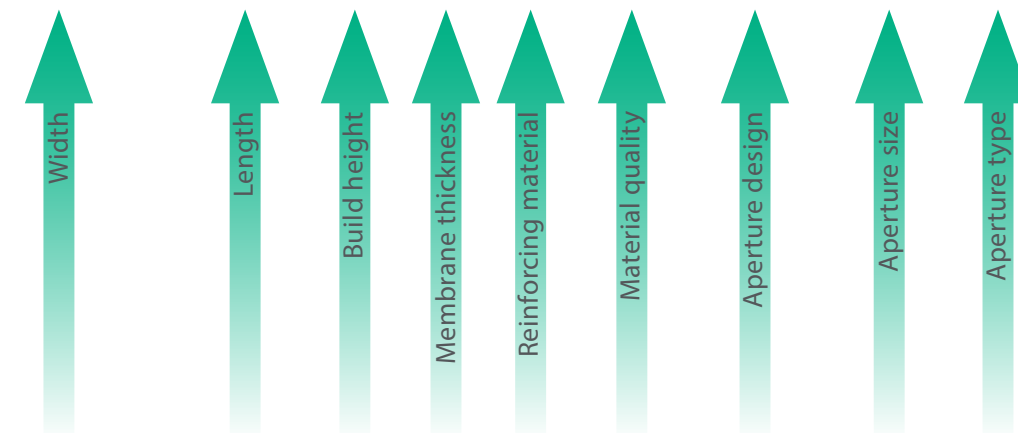

Material quality

T40 = Trellex 40
(Soft, Flexible rubber 40Sh-A)
T60 = Trellex 60
(Standard rubber 60Sh-A)
T60S = Trellex 60 Super
(Extra wear resistant 60Sh-A)
SF = Steel frame

Aperture design

SLS = Slot with flow
STS = Slot against flow
FR = Square opening

Aperture type

P = Punched
M = Molded

Selection guide

Separation versus opening Metso CVB

18° inclined screens, circular motion

Cut size (mm)	Opening (mm)							
	Trellex PCL - S		Trellex CLS		PU		Rubber	
	Gravel	Crushed	Gravel	Crushed	Gravel	Crushed	Gravel	Crushed
1	1	1.2	1.12	1.25				
1.25	1.3	1.5	1.4	1.6				
1.6	1.75	2	1.8	2				
2	2.2	2.5	2.24	2.5				
2.5	2.5	3	2.8	3.15				
3.15	3.3	3.5	3.55	4				
4	4.2	4.5	4.5	5	5	5.6	5.5	6.3
5	5.5	6	5.6	6.3	6.3	7.1	6.5	7.5
6.3	7	7.5	7.1	8	7.1	8.5	7.5	8.5
7.1	7.5	8	8	9	8.5	9.5	8.5	9.5
8	9	10	9	10	9.5	10.5	9.5	10.5
9	10	11	10	11.2	10.5	11.5	11	12
10	11	12	11.2	12.5	12	13	12.5	13.5
11.2	12	13	12.5	13.7	13.5	14.5	14.5	15.5
12.5	14	15	14	15	14.5	16	16	17
14	15	16	16	17	16.5	18	18	19
16	18	19	18	19	18.5	20	20	21
18	20	21	20	21	20	23	23	24
20	22	23	22	23	22.4	25	25	26
22.4	24	25	24	25	25	28	27	29
25			27	28	28	31.5	31.5	33.5
28			30	31.5	31.5	35.5	35	37
31.5			34	35.5	35.5	38	38	40
35.5			38	40	38	40	43	45
40			43	45	42	45	50	52
45			48	50	48	50	55	57
50			53	56	53	56	60	62
63			65	70	65	68	74	76
80			85	90	85	90	98	100
100			105	112	105	112	115	120
120							135	140
150							170	175
180							205	215
200							220	235

Selection guide

Separation versus opening Metso TS

Multislope screen, 25°20°15°, variable elliptical motion

Cut size (mm)	Opening (mm)																							
	Trellex PCL - S						Trellex CLS						PU						Rubber					
	Gravel			Crushed			Gravel			Crushed			Gravel			Crushed			Gravel			Crushed		
	15°	20°	25°	15°	20°	25°	15°	20°	25°	15°	20°	25°	15°	20°	25°	15°	20°	25°	15°	20°	25°	15°	20°	25°
1	1	1	1.2	1.2	1.2	1.3	1.12	1.12	1.25	1.25	1.25	1.5												
1.25	1.3	1.3	1.5	1.5	1.5	1.8	1.4	1.4	1.6	1.6	1.6	1.9												
1.6	1.75	1.75	2	2	2	2.2	1.8	1.8	2	2	2	2.24												
2	2.2	2.2	2.5	2.5	2.5	3	2.24	2.24	2.8	2.5	2.5	3.15												
2.5	2.5	2.5	3.3	3	3	3.5	2.8	2.8	3.55	3.15	3.15	4												
3.15	3.3	3.3	4.2	3.5	3.5	4.5	3.55	3.55	4.5	4	4	5												
4	4.2	4.2	5.5	4.5	4.5	6	4.5	4.5	5.6	5	5	6.3	5	5.5	6.5	5.5	6	6.5	5.4	6	6.5	6	6.5	7
5	5.5	5.5	7	6	6	7.5	5.6	5.6	7.1	6.3	6.3	8	6	6.5	7	7	8	9	6.5	7	8	7	8	9
6.3	7	7	7.5	7.5	7.5	8	7.1	7.1	8	8	8	9	7	8	9	8	9	10	7	8	9	8	9	10
7.1	7.5	7.5	9	8	8	10	8	8	9	9	9	10	8	9	10	9	10	11	8	9	10	9	10	11
8	9	9	10	10	10	11	9	9	10	10	10	11.2	9	10	11	10	11	12	9	10	11	10	11	12
9	10	10	11	11	11	12	10	10	11.2	11.2	11.2	12.5	10	11	12	10	12	13	11	12	13	12	13	14
10	11	11	12	12	12	13	11.2	11.2	12.5	12.5	12.5	13.7	12	13	14	13	13	14	12	13	14	13	14	15
11.2	12	12	14	13	13	15	12.5	12.5	14	13.7	13.7	15	13	14	15	14	15	16	14	15	16	15	16	17
12.5	14	14	15	15	15	16	14	14	16	15	15	17	14	15	16	16	16	17	16	16	17	17	17	18
14	15	15	18	16	16	19	16	16	18	17	17	19	16	17	18	18	18	19	18	18	19	19	19	20
16	18	18	20	19	19	21	18	18	20	19	19	21	18	19	20	20	20	22	20	20	22	20	21	22
18	20	20	22	21	21	23	20	20	22	21	21	23	20	20	22	23	23	25	23	23	25	24	24	26
20	22	22	24	23	23	25	22	22	24	23	23	25	22	23	25	25	25	27	25	25	27	26	26	28
22.4	24	24	27	25	25	28	24	24	27	25	25	28	25	25	27	28	28	30	27	27	29	29	29	31
25							27	27	30	28	28	31.5	28	28	30	31	31	34	31	31	34	33	33	36
28							30	30	34	31.5	31.5	35.5	31	31	34	35	35	38	35	35	38	37	37	40
31.5							34	34	38	35.5	35.5	40	35	35	38	38	38	40	38	38	40	40	40	44
35.5							38	38	43	40	40	45	38	38	42	40	40	45	43	43	48	45	45	50
40							43	43	48	45	45	50	42	42	48	45	45	50	50	50	55	52	52	57
50							53	53	56	56	56	63							62	62	64	64	64	67
63							65	65	70	70	70	75							76	76	80	78	78	82
70							75	75	80	80	80	85							88	88	92	90	90	94



Screening Process Theory

Screening Process Theory

Screening is almost like science, in order to easier understand the screening process, there are some parts of the screening theory we think is important to share with you. In this chapter we explain and illustrate selected parts of the screening theory to make it possible for you to optimize your screening process and reach the result you expect.

- Size distribution - critical content
- Particle shape influence - cubic, round, flaky/slabby and needle
- Common requirements on aggregate - fraction, top size, oversize, nominal content, undersize
- Fraction length - long and short fraction
- Screening efficiency - recovery and removal of under sized material
- Moisture content in the feed - how it affects the screenability
- Capacity affecting parameters
- Open area - effective and relative open area
- Dewatering drainage rate



Screening Process Theory

Size Distribution - Critical content

Critical content is defined as the fine particle size in the feed, typically between 0.5 to 1 x separation/cut size. These are the particles that are most difficult to screen.

A high critical content will make the screening application more difficult and might require high open area products or other actions to meet the requirements. For critical content over 30 % you need to be aware of the problem and be extra careful.

- The fines particles (< 0.5 x separation/cut size) are very easy to screen, they pass through apertures very easily
- The coarse particles (>1.5 x separation/cut size) are very easy to screen, as it is impossible to pass through the aperture
- "Critical particles" (0.5 to 1 x separation/cut size) or "near sized" particles (0.5 to 1.5 x separation/cut size), are the most difficult particles to screen.

How to decrease a critical content

- Crusher settings
- Change apertures in previous screens or screen deck

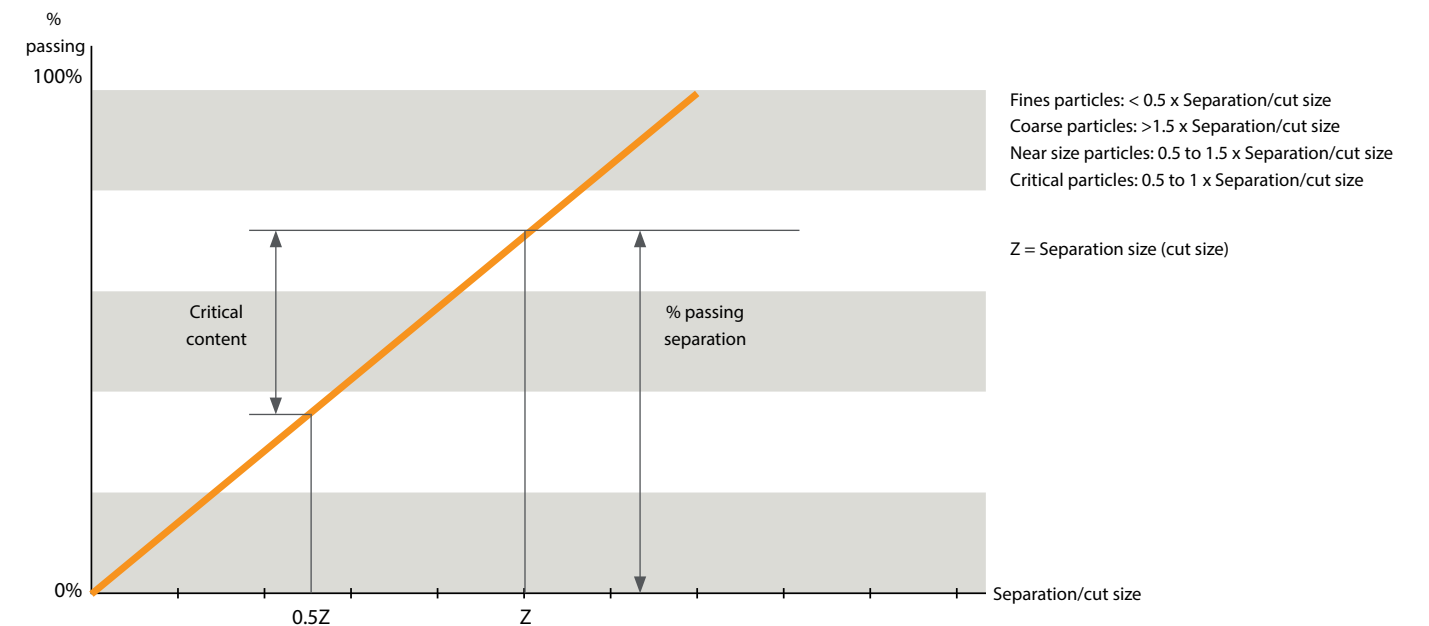

Screening Process Theory

Particle shape influence

A stable particle shape from the crushers in the plant results in a better screening result. Round shaped particles close to the aperture size are easily separated and end up as oversize. Flaky material close to the aperture size is more difficult to separate.

The screening of irregular shape (slabby, needle) material is more difficult. More screening area is required to get the same efficiency compared to round/cubic material. For round and cubic material it is possible to use slot apertures, resulting in higher capacity.

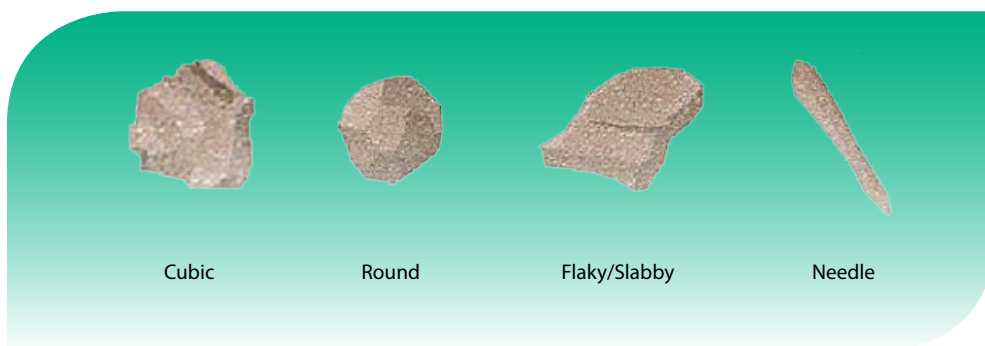

Flaky particles affects the screening process

- Flaky material has more surface in relation to particle shape, which results in:
- Poor stratification - problem passing the deck
 - More surface gives more friction when passing holes
 - Less movement in the material bed. Affects both throughput and the carry-over material

Note: Flaky material behaves differently on a laboratory screen as they can pass more easily.

Screening Process Theory

Common requirements on aggregate

For aggregate, national standards are typically stipulating demands/ requirements on specific fractions. Standards also define how to take samples and carry out laboratory test.

In case of no standards, specifications must be known before starting to make any changes to screen media or crusher settings. Graph shows a typical definition of a fraction. Nominal content (fraction) together with maximum undersize and oversized content is normally the minimum requirement.

- (T) Maximum particle size
- (O) Maximum percentage oversize
- (N) Nominal content within fraction limits
- (U) Maximum percentage undersize

Specifications must be known before starting to make any changes

Other specific requirements as particle shape, crushed surface ratio, flaky index etc. are common as well.

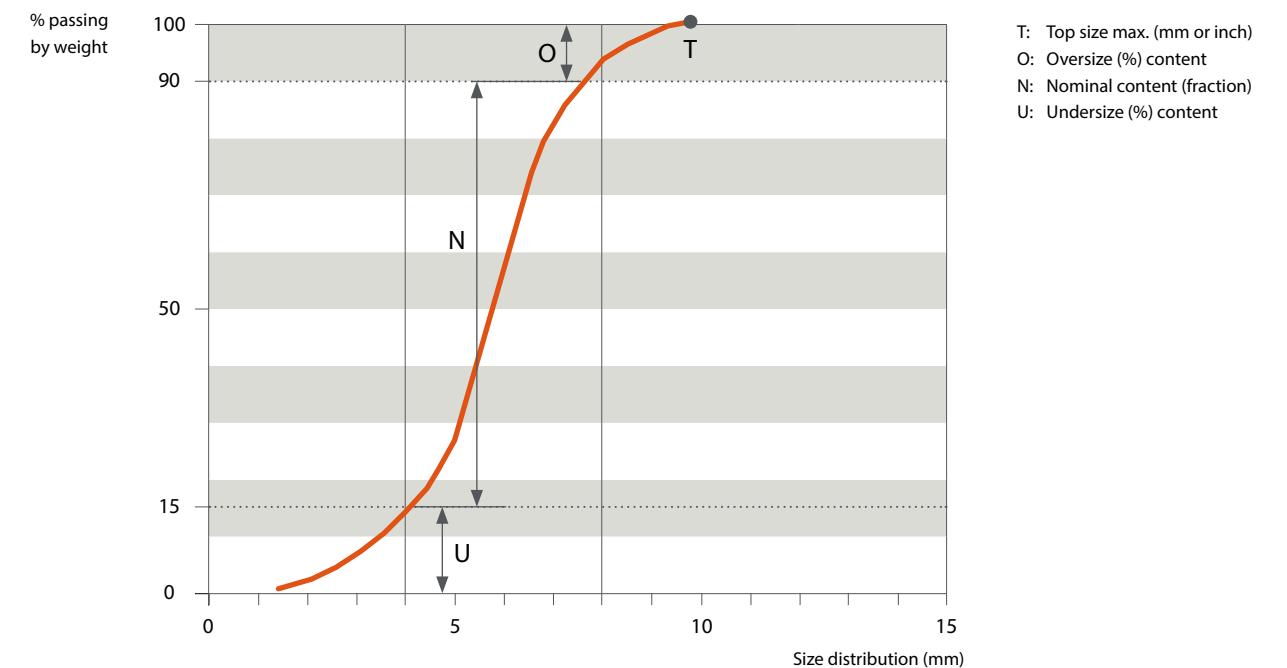

Screening Process Theory

Screening efficiency

Efficiency concepts (%)

There are several ways of calculating screening efficiency and therefore it is important to define what kind of screening efficiency we refer to.

Below we define two common screening efficiency calculations:

- Undersize removal (common in mining, no relevance in aggregate)
- Recovery (common in aggregate and in mining)

Screening efficiency can be misleading. What is good or bad depends on what it is being compared to. It is recommended to use screening efficiency as an indicator when making improvement in the screen process and not as an absolute measurement.

Undersize removal

Undersize removal is common in mining but has no relevance in aggregate.

$$\text{Screening efficiency} = 100 - \frac{\text{Tonnage of undersize passing over the deck (X)}}{\text{Total tonnage passing over the deck (Y)}} \times 100$$

Example: Undersize removal

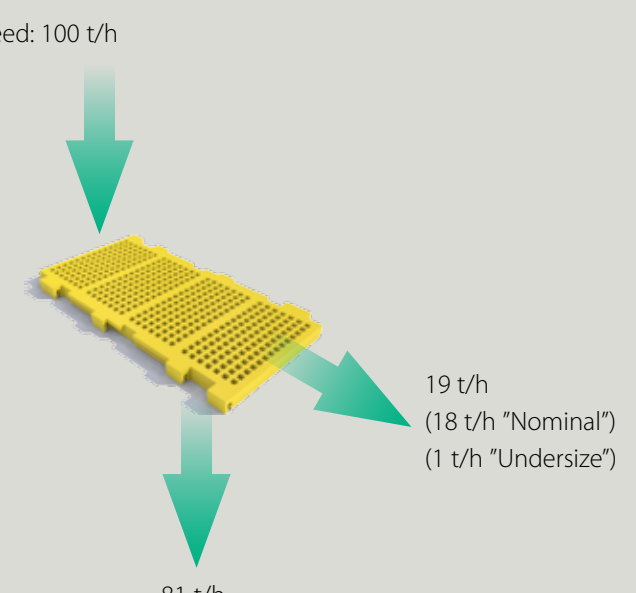

Feed: 100 t/h

19 t/h (18 t/h "Nominal") (1 t/h "Undersize")

81 t/h

E = Screening efficiency
 X = Undersize passing over the deck (t)
 Y = Total tonnage passing over the deck
 $U_o = X/Y$

In our example:

Y = 19 t/h
 X = 1 t/h
 $U_o = 1/19 = 5.3\%$
 $E = 100 - U_o = 100 - 5.3 = 94.7\%$

The result of screening efficiency using undersize removal method is 94.7%



Recovery

Recovery efficiency is common in aggregate. This concept is used in Bruno software.

$$\text{Screening efficiency} = \frac{\text{Feed passing through the screen deck (X)}}{\text{Feed that theoretically can pass through the screen deck (Y)}} \times 100$$

Example: Recovery efficiency concept at 3 mm separation

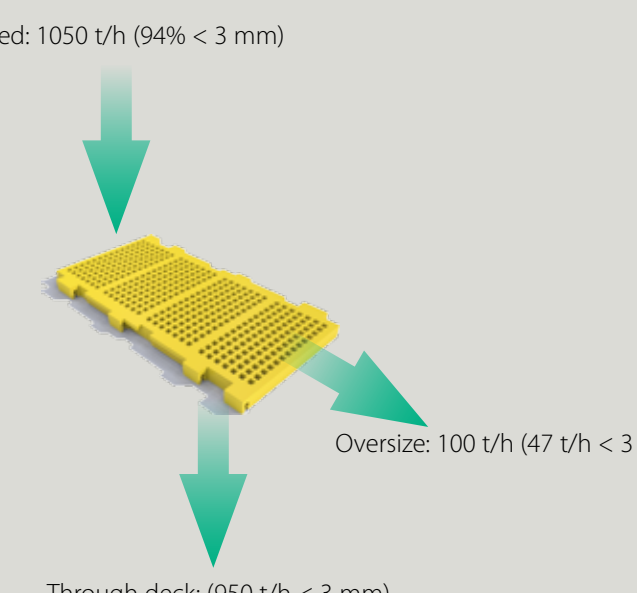

Feed: 1050 t/h (94% < 3 mm)

Through deck: (950 t/h < 3 mm)

Oversize: 100 t/h (47 t/h < 3 mm)

E = Screening efficiency
 X = Feed passing through the screen deck
 Y = Feed that theoretically can pass through the screen deck
 $E = X/Y \times 100$

In our example:

$E = 940/987 \times 100 = 95.2\%$

where

X = 940 t/h
 Y = 94% x 1050 t/h



Screening Process Theory

Moisture content in the feed

Moisture content in the feed material affects the screenability. At a certain moisture content percentage it is more or less impossible to screen the material either due to the screen deck being completely blinded or the material agglomerates.

Different materials tend to be more sticky than others. Materials with high clay content or fine ore are two examples of material that often causes these problems. In general all fine materials becomes sticky and difficult to screen as the moisture content is unfavorable. In the graph below, screenability in relation to moisture content is indicating if it is possible to screen or not. By adding water to the material it will make it possible to screen. A moisture content below 4% is a favourable condition for "dry screening".

Note: By using a screen media with a flexible membrane, screening is possible in moisty conditions. We recommend Trellex LS HiPer Clean modules for best result. For tensioned products choose Trellex TFX.

$$\text{Moisture content \%} = \frac{\text{Dried sample weight}}{\text{Sample weight}} \times 100\%$$

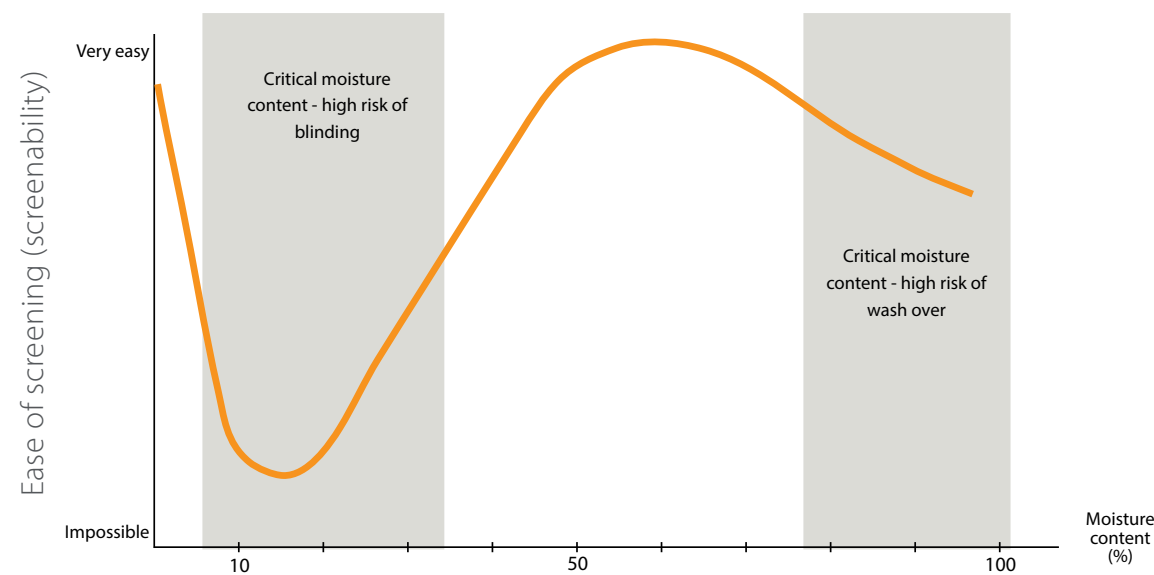

Screening Process Theory

Capacity affecting parameters

Aperture type affects capacity

Different aperture types affects capacity. If we compare a square opening with a longitudinal slot (in direction of flow), we will experience a higher throughput with a longitudinal slot compared to the square aperture, even if the effective open area is the same.

The main reason to a higher troughput is a different geometry with less obstructions for an undersized particle way through the deck. The probability for the same particle to find the way through the deck is also higher.

Membrane thickness affects capacity

A thinner screening media membrane affects capacity through the deck in a positive way. Due to less friction and shorter distance through the aperture, capacity is normally higher for a thin membrane compared to a thicker.

Material bed thickness affects capacity

A common situation is a too thick bed depth that obstruct the material to stratify in an optimal way. This affects the capacity in a negative way. Also a too thin bed depth will affect the capacity in a negative way. A clear sign of thin bed depth is bouncing material. This is typically seen as undersized material in a fraction.

An optimal bed depth (D) is normally 4 times the aperture size measured at the discharge end of the screen.

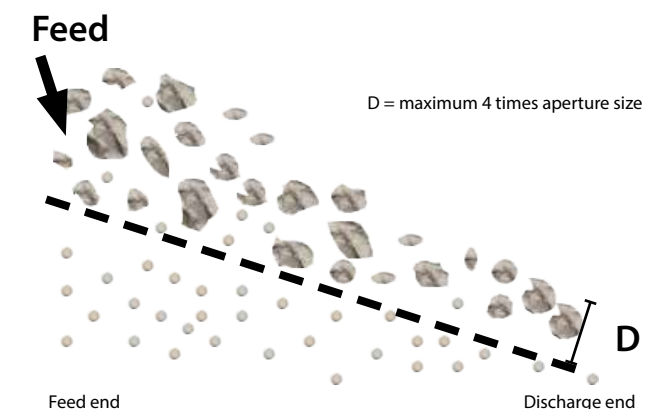

Material Shape affects capacity

Different material shape or geometry affects the capacity. It is easy to understand that a round and smoth material is easier to screen compared to a flaky and slabby material. In this situation it might be necessary to change aperture type to a slot, or even look into the crusher setting. Even a different type of crusher could be necessary that makes the material less slabby.

Riding bars affects capacity

Riding bars can increase the capacity if the bigger lumps in the feed are lifted up from the screening surface allowing the undersized material to pass through. This is common in coarser applications but could be of advantage in many finer applications as well.

An additional feature with riding bars is the increased lifetime. Over a longer period, the screening media lifetime is important to utilise maximum available production time. To change screening media frequently will affect capacity to a high extent. As much as 5 to 10 % of available production time can be lost when using screen media which require frequent changes.

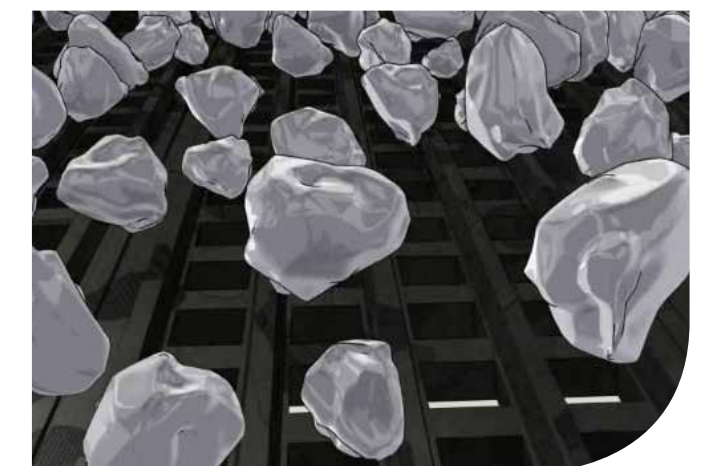

Screening Process Theory

Open Area

What is Open Area?

There are different types of open area but also different ways to calculate open area. To avoid any misunderstanding it is important to fully understand the difference.

The most common types of open area are:

- Effective Open Area
- Relative Open Area



Screening Process Theory

Effective Open Area (EOA)

To calculate EOA for a LS module

Effective Open Area (EOA) is common for synthetic screen media. Definitions can differ so it is recommended to verify the actual EOA.

EOA % is the total aperture area divided with total module area.

By re-defining effective module area $X_1 X_2$ it is possible to get a more favourable EOA. In practice EOA% is calculated as total aperture area per module divided by total effective area of the module corresponding to $X_1 X_2$.

$$EOA \% = \frac{\text{Total aperture area}}{\text{Total area}}$$

Example: Calculation of effective open area calculated for 305LS-610-30-8-75/90-FR8EXM-E

$X_1 = 305 \text{ mm}$
 $X_2 = 610 \text{ mm}$
 Aperture FR8 ($8 \times 8 \text{ mm} = 64 \text{ mm}^2$)
 No. of apertures: 1176

$$EOA \% = \frac{\text{No. of aperture} \times \text{Aperture area}}{\text{Total effective area}}$$

$$EOA \% = \frac{1176 \times 8 \times 8}{305 \times 610} = 40.5\%$$

Both EOA and ROA is given for all modules in this handbook.

Screening Process Theory

Relative Open Area

Relative open area (ROA) is the most common way of describing open area for tensioned screen cloths, wire mesh, rubber or polyurethane. In order to calculate ROA we only need to know the aperture size and the pitch between the apertures.

Relative open area calculation is a heritage from wire industry. The calculation does not take the product size or blind areas in consideration.

Example: Calculation of relative open area (ROA)

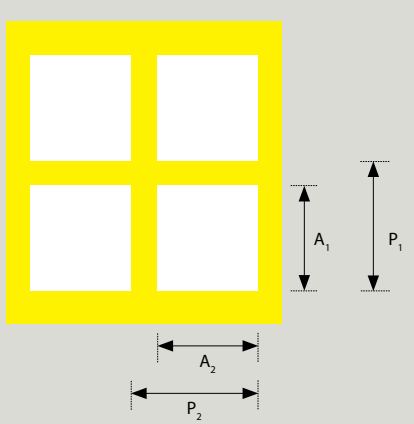

$$ROA\% = \frac{A_1 \times A_2}{P_1 \times P_2} \times 100$$

Example

$A_1 = A_2 = 18 \text{ mm}$

$P_1 = P_2 = 26 \text{ mm}$

$ROA\% = (324/676) \times 100 = 47.9\%$

Screening Process Theory

Comparing EOA to ROA

Wire mesh compared to modular system

Wire v.s Trellex LS HiPer Flow

Most of us are aware of the high open area advantage when using a traditional wire cloth. But the difference is not that big if we compare EOA with EOA (apples with apples). Looking at a screen deck with a traditional side tensioned wire cloth, in average 15% of the available deck area is actually blinded by longitudinal supports and clamping bars. In many cases it is as much as 25% of the deck area that is blinded. If we compare with Trellex LS HiPer Flow (high open area modules) we can notice the difference is not that big. Also to be considered, transport speed of the material differs if we are using wire or synthetic screen media. The transport

speed is lower for wire cloth (approx. 0.3 m/s = 1'/s), while for synthetic media it can be as much as double the speed. It means that if capacity is available in the screen, it is possible to process more material (tonnes/h) with a high open area synthetic deck. Additionally a flat deck (instead of a crowned deck) will normally contribute to higher screening efficiency as the bed depth is the same over the width of the screen.

Illustration: Cross section of a screen deck showing longitudinal supports for side tensioned wire cloth

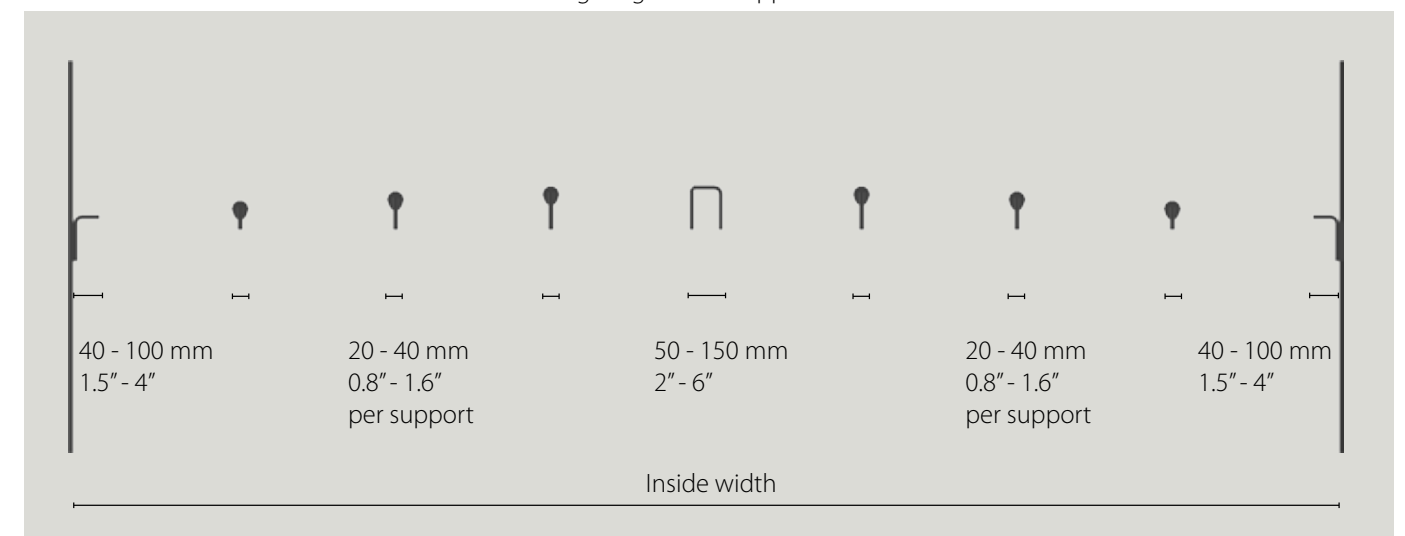

If inside width = 8' = 2440 mm
 Min. blind area is: $((6 \times 20) + (2 \times 40) + 50) / 2440 \times 100 = 10.3\%$ (corresponds to 250 mm (10"))
 Max. blind area is: $((6 \times 40) + (2 \times 100) + 150) / 2440 \times 100 = 24.4\%$ (corresponds to 590 mm (23.3"))
 In average approx. 15 % of the surface is blind and not considered when using wire cloth and relative open area calculation.

Screening Process Theory

Comparing EOA to ROA

Wire mesh compared to modular system

Illustration: A flat deck frame for modular screening media will in most cases increase screening efficiency as the material is distributed evenly over the deck surface.

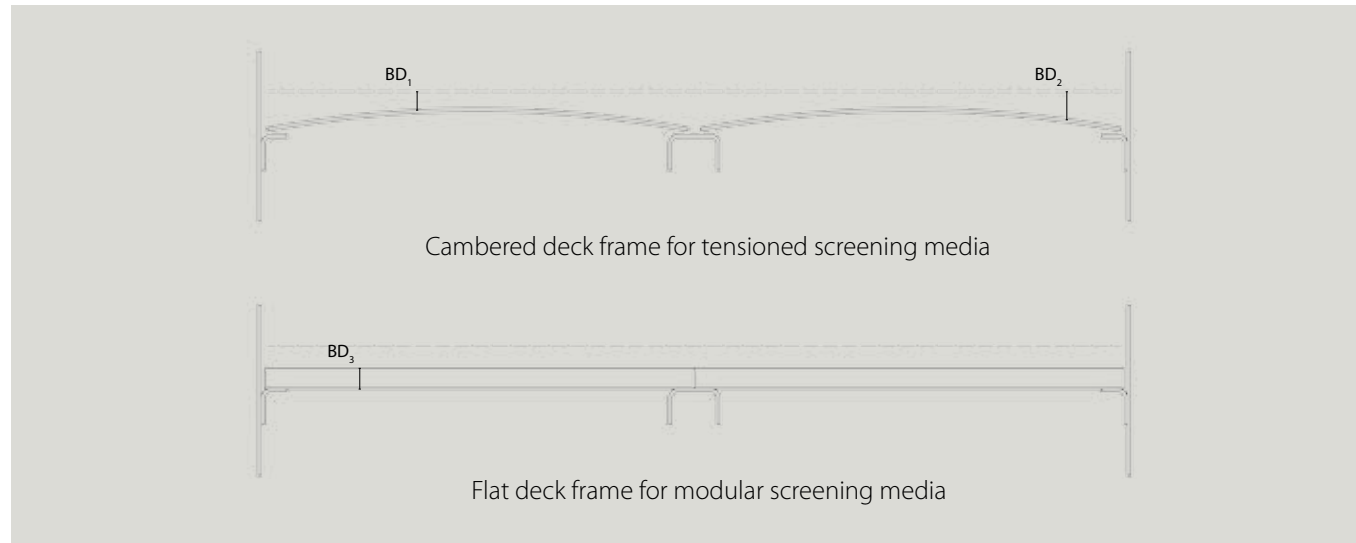

- BD_1 Bed depth at the top of the cambered deck. Risk of bouncing material and inefficient screening due to low material bed depth in this area.
- BD_2 Bed depth at the lowest point of a cambered deck. Risk of premature wear and inefficient screening due to high bed depth in this area.
- BD_3 Bed depth is distributed evenly over the screen with and will result in an efficient screening if bed depth is correct.



Screening Process Theory

Dewatering drainage rate

Use below graph to compare dewatering drainage rate in comparison to available Effective open area. The graph is an indicate tool.

